



MODEL T360/T360M CARBON DIOXIDE ANALYZER Operation Manual

Also supports operation of:

T360U/GFC 7000E CO2 Analyzer

(when used in conjunction with T360U/GFC 7000E Addendum, PN 07273)

© Teledyne Advanced Pollution Instrumentation (TAPI)
9480 Carroll Park Drive
San Diego, CA 92121-5201
USA

Toll-free Phone: 800-324-5190
Phone: 858-657-9800
Fax: 858-657-9816
Email: api-sales@teledyne.com
Website: <http://www.teledyne-api.com/>

ABOUT TELEDYNE ADVANCED POLLUTION INSTRUMENTATION (TAPI)

Teledyne Advanced Pollution Instrumentation, Inc. (TAPI) is a worldwide market leader in the design and manufacture of precision analytical instrumentation used for air quality monitoring, continuous emissions monitoring, and specialty process monitoring applications. Founded in San Diego, California, in 1988, TAPI introduced a complete line of Air Quality Monitoring (AQM) instrumentation, which comply with the United States Environmental Protection Administration (EPA) and international requirements for the measurement of criteria pollutants, including CO, SO₂, NO_x and Ozone.

Since 1988 TAPI has combined state-of-the-art technology, proven measuring principles, stringent quality assurance systems and world class after-sales support to deliver the best products and customer satisfaction in the business.

For further information on our company, our complete range of products, and the applications that they serve, please visit www.teledyne-api.com or contact sales@teledyne-api.com.

NOTICE OF COPYRIGHT

© 2011-2012 Teledyne Advanced Pollution Instrumentation. All rights reserved.

TRADEMARKS

All trademarks, registered trademarks, brand names or product names appearing in this document are the property of their respective owners and are used herein for identification purposes only.

This page intentionally left blank.

SAFETY MESSAGES

Important safety messages are provided throughout this manual for the purpose of avoiding personal injury or instrument damage. Please read these messages carefully. Each safety message is associated with a safety alert symbol, and are placed throughout this manual; the safety symbols are also located inside the instrument. It is imperative that you pay close attention to these messages, the descriptions of which are as follows:



WARNING: Electrical Shock Hazard



HAZARD: Strong oxidizer



GENERAL WARNING/CAUTION: Read the accompanying message for specific information.



CAUTION: Hot Surface Warning



Do Not Touch: Touching some parts of the instrument without protection or proper tools could result in damage to the part(s) and/or the instrument.



Technician Symbol: All operations marked with this symbol are to be performed by qualified maintenance personnel only.



Electrical Ground: This symbol inside the instrument marks the central safety grounding point for the instrument.

CAUTION



This instrument should only be used for the purpose and in the manner described in this manual. If you use this instrument in a manner other than that for which it was intended, unpredictable behavior could ensue with possible hazardous consequences.

NEVER use any gas analyzer to sample combustible gas(es)!

For Technical Assistance regarding the use and maintenance of this instrument or any other Teledyne API product, contact Teledyne API's Technical Support Department:

Telephone: 800-324-5190

Email: sda_techsupport@teledyne.com

or access any of the service options on our website at <http://www.teledyne-api.com/>

CONSIGNES DE SÉCURITÉ

Des consignes de sécurité importantes sont fournies tout au long du présent manuel dans le but d'éviter des blessures corporelles ou d'endommager les instruments. Veuillez lire attentivement ces consignes. Chaque consigne de sécurité est représentée par un pictogramme d'alerte de sécurité; ces pictogrammes se retrouvent dans ce manuel et à l'intérieur des instruments. Les symboles correspondent aux consignes suivantes :



AVERTISSEMENT : Risque de choc électrique



DANGER : Oxydant puissant



AVERTISSEMENT GÉNÉRAL / MISE EN GARDE : Lire la consigne complémentaire pour des renseignements spécifiques



MISE EN GARDE : Surface chaude



Ne pas toucher : Toucher à certaines parties de l'instrument sans protection ou sans les outils appropriés pourrait entraîner des dommages aux pièces ou à l'instrument.



Pictogramme « technicien » : Toutes les opérations portant ce symbole doivent être effectuées uniquement par du personnel de maintenance qualifié.



Mise à la terre : Ce symbole à l'intérieur de l'instrument détermine le point central de la mise à la terre sécuritaire de l'instrument.

MISE EN GARDE



Cet instrument doit être utilisé aux fins décrites et de la manière décrite dans ce manuel. Si vous utilisez cet instrument d'une autre manière que celle pour laquelle il a été prévu, l'instrument pourrait se comporter de façon imprévisible et entraîner des conséquences dangereuses.

NE JAMAIS utiliser un analyseur de gaz pour échantillonner des gaz combustibles!

WARRANTY

Warranty Policy (02024 F)

Teledyne Advanced Pollution Instrumentation (TAPI), a business unit of Teledyne Instruments, Inc., provides that:

Prior to shipment, TAPI equipment is thoroughly inspected and tested. Should equipment failure occur, TAPI assures its customers that prompt service and support will be available.

COVERAGE

After the warranty period and throughout the equipment lifetime, TAPI stands ready to provide on-site or in-plant service at reasonable rates similar to those of other manufacturers in the industry. All maintenance and the first level of field troubleshooting are to be performed by the customer.

NON-TAPI MANUFACTURED EQUIPMENT

Equipment provided but not manufactured by TAPI is warranted and will be repaired to the extent and according to the current terms and conditions of the respective equipment manufacturer's warranty.

Product Return

All units or components returned to Teledyne API should be properly packed for handling and returned freight prepaid to the nearest designated Service Center. After the repair, the equipment will be returned, freight prepaid.

The complete Terms and Conditions of Sale can be reviewed at http://www.teledyne-api.com/terms_and_conditions.asp

CAUTION – Avoid Warranty Invalidation



Failure to comply with proper anti-Electro-Static Discharge (ESD) handling and packing instructions and Return Merchandise Authorization (RMA) procedures when returning parts for repair or calibration may void your warranty. For anti-ESD handling and packing instructions please refer to "Packing Components for Return" in the *Primer on Electro-Static Discharge* section of this manual, and for RMA procedures please refer to our Website at <http://www.teledyne-api.com> under Customer Support > Return Authorization.

This page intentionally left blank.

ABOUT THIS MANUAL

This manual, PN 07272, provides operation instructions for Models T360 and T360M, and supports operation of the Model T360U (when used in conjunction with the T360U/GFC7000E Addendum, PN 07273). This manual is comprised of multiple documents as listed below.

Part No.	Rev	Name/Description
07272	B	T360 Carbon Dioxide Analyzer Operation Manual
05233	C	Menu trees and software documentation (inserted as Appendix A of this manual)
06879	1/4/2011	Spare Parts List (located in Appendix B, this manual)
05235	C	Repair Request Questionnaire (inserted as Appendix C of this manual)
Interconnects and Schematics included in Appendix D of this manual		
0691201	B	Interconnect Wire List (located in Appendix D of this manual)
06912	B	Interconnect Wiring Diagram (located in Appendix D of this manual)
03297	K	PCA, 03296, IR Photodetector Preamp and Sync Demodulator
03632	C	PCA, 03631, 0-20mA driver
04003	N	PCA, 04003, Pressure/Flow Transducer Interface
04089	A	PCA, 04088, Opto Pickup Interface
04136	B	PCA, 04135 Rev A, Relay
04468	B	PCA, 04467, Analog Output Series Res
05803	B	SCH, PCA 05802, MOTHERBOARD, GEN-5
06698	D	SCH, PCA 06697, INTRFC, LCD TCH SCRIN,
06882	B	SCH, LVDS TRANSMITTER BOARD
06731	B	SCH, AUXILLIARY-I/O BOARD

NOTE

Please read this manual in its entirety before making any attempt made to operate the instrument.

REVISION HISTORY

T360 Manual PN 07272			
Date	Rev	DCN	Change Summary
2012 Dec 13	B	6552	Administrative updates; minor technical updates
2011 Jan 12	A	5950	Initial Release

This page intentionally left blank.

TABLE OF CONTENTS

ABOUT TELEDYNE ADVANCED POLLUTION INSTRUMENTATION (TAPI).....	i
SAFETY MESSAGES	iii
CONSIGNES DE SÉCURITÉ.....	iv
WARRANTY.....	v
ABOUT THIS MANUAL.....	vii
TABLE OF CONTENTS	ix
1. INTRODUCTION.....	17
1.1. Features	17
1.2. Using This Manual.....	17
1.3. Options	18
2. SPECIFICATIONS AND APPROVALS	21
2.1. Specifications	21
2.2. Approvals and Certifications.....	23
2.2.1. Safety	23
2.2.2. EMC.....	23
3. GETTING STARTED	25
3.1. Unpacking and Initial Set Up.....	25
3.2. Front Panel.....	27
3.3. Rear Panel	31
3.4. Internal Layout	33
3.5. Electrical Connections.....	35
3.5.1. Power Connection	35
3.5.2. Connecting Analog Inputs (Option 64B)	36
3.5.3. Connecting Analog Outputs.....	36
3.5.4. Connecting the Status Outputs.....	38
3.5.5. Current Loop Analog Outputs (Option 41)	39
3.5.6. Connecting the Control Inputs	40
3.5.7. Connecting the Alarm Relay Option (OPT 61).....	42
3.5.8. Connecting the Communications Interfaces	43
3.6. Pneumatic Connections	44
3.6.1. Basic Pneumatic Connections	44
3.6.2. Connections with Ambient Zero/Ambient Span Valve.....	48
3.6.3. Connections with Ambient Zero/Pressurized Span Valve Option	50
3.6.4. Pneumatic Connections in Multipoint Calibration Applications.....	53
3.6.5. Setting the Internal Purge Air Pressure	53
3.7. Initial Operation	54
3.7.1. Startup	54
3.7.2. Warm Up.....	55
3.7.3. Warning Messages	55
3.7.4. Functional Checks	57
3.8. Initial Calibration Procedure	58
3.8.1. Initial O ₂ Sensor Calibration Procedure	61
4. OPERATING INSTRUCTIONS	67
4.1. Overview of Operating Modes	67
4.2. Sample Mode	68
4.2.1. Test Functions	69
4.2.2. Warning Messages	70
4.3. Calibration Mode	72
4.4. Setup Mode.....	73
4.5. Setup → CFG: Viewing the Analyzer's Configuration Information.....	74
4.6. SETUP → ACAL: Automatic Calibration	74
4.7. SETUP → DAS: Using the Data Acquisition System (DAS).....	75
4.7.1. DAS Structure.....	76
4.7.2. Default DAS Channels	78
4.7.3. Remote DAS Configuration.....	94
4.8. SETUP → RNGE: Analog Output Reporting Range Configuration	95
4.8.1. Physical Range versus Analog Output Reporting Ranges.....	96
4.8.2. Reporting Range Modes.....	96
4.8.3. Single Range Mode (SNGL).....	98

4.8.4. Dual Range Mode (DUAL).....	99
4.8.5. Auto Range Mode (AUTO).....	100
4.8.6. Range Units.....	101
4.8.7. Dilution Ratio.....	102
4.9. SETUP → PASS: Password Feature.....	103
4.10. SETUP → CLK: Setting the Internal Time-of-Day Clock.....	105
4.11. SETUP → MORE → COMM: Using the Analyzer's Communication Ports.....	107
4.11.1. Machine ID.....	107
4.11.2. COM Port Default Settings.....	108
4.11.3. RS-485 Configuration of COM2.....	111
4.11.4. DTE and DCE Communication.....	111
4.11.5. COM Port Communication Modes.....	112
4.11.6. Remote Access via the Ethernet.....	114
4.11.7. USB Port Setup.....	120
4.11.8. Multidrop RS-232 Setup.....	122
4.11.9. MODBUS Setup.....	125
4.11.10. COM Port Baud Rate.....	127
4.11.11. COM Port Testing.....	128
4.12. SETUP → MORE → VARS: Internal Variables (VARS).....	129
4.13. SETUP → MORE → DIAG: Using the Diagnostics Functions.....	131
4.13.1. Accessing the Diagnostic Features.....	132
4.13.2. Signal I/O.....	133
4.13.3. Analog Output Step Test.....	134
4.13.4. Analog I/O Configuration.....	135
4.13.5. Electric Test.....	146
4.13.6. Dark Calibration Test.....	147
4.13.7. Pressure Calibration.....	148
4.13.8. Flow Calibration.....	149
4.13.9. Test Channel Output.....	150
4.14. SETUP → MORE → ALRM: Using the Gas Concentration Alarms.....	151
4.14.1. Setting the Concentration Alarm Limits.....	151
4.15. Remote Operation of the Analyzer.....	152
4.15.1. Remote Operation Using the External Digital I/O.....	152
4.15.2. Remote Operation Using the External Serial I/O.....	155
4.15.3. Additional Communications Documentation.....	161
4.15.4. Using the T360 with a Hessen Protocol Network.....	162
5. CALIBRATION PROCEDURES.....	169
5.1. Before Calibration.....	169
5.1.1. Zero Air and Span Gas.....	169
5.1.2. Calibration Gas Traceability.....	170
5.1.3. Data Recording Devices.....	170
5.2. Manual Calibration without Zero/Span Valves.....	170
5.3. Manual Calibration Checks.....	173
5.4. Manual Calibration with Zero/Span Valves.....	173
5.5. Manual Calibration Checks with Zero/Span Valves.....	178
5.5.1. Zero/Span Calibration on Auto Range or Dual Ranges.....	179
5.5.2. Use of Zero/Span Valves with Remote Contact Closure.....	180
5.6. Automatic Zero/Span Cal/Check (AutoCal).....	180
5.6.1. AutoCal with Auto or Dual Reporting Ranges Modes Selected.....	183
5.7. Calibration Quality.....	184
6. MAINTENANCE SCHEDULE AND PROCEDURES.....	185
6.1. Maintenance Schedule.....	185
6.2. Predicting Failures Using the Test Functions.....	189
6.3. Maintenance Procedures.....	190
6.3.1. Replacing the Sample Particulate Filter.....	190
6.3.2. Rebuilding the Sample Pump.....	191
6.3.3. Performing Leak Checks.....	191
6.3.4. Performing a Sample Flow Check.....	192
6.3.5. Cleaning the Optical Bench.....	192
6.3.6. Cleaning the Chassis.....	192
7. PRINCIPLES OF OPERATION.....	193
7.1. Measurement Method.....	193

7.1.1. Beer's Law	193
7.1.2. Measurement Fundamentals	194
7.1.3. Gas Filter Correlation.....	194
7.1.4. Interference and Signal to Noise Rejection.....	197
7.2. Oxygen Sensor (OPT 65).....	198
7.2.1. Paramagnetic Measurement of O ₂	198
7.3. Pneumatic Operation.....	200
7.3.1. Sample Gas Flow	200
7.3.2. Flow Rate Control	201
7.3.3. Purge Gas Pressure Control.....	202
7.3.4. Particulate Filter.....	202
7.3.5. Pneumatic Sensors.....	202
7.3.6. Pneumatic Operation of the O ₂ Sensor.....	203
7.4. Electronic Operation.....	204
7.4.1. Overview.....	204
7.4.2. CPU	206
7.4.3. Optical Bench & GFC Wheel	207
7.4.4. Synchronous Demodulator (Sync/Demod) Assembly	210
7.4.5. Relay Board	212
7.4.6. Motherboard	215
7.4.7. I ² C Data Bus	217
7.4.8. Power Supply/ Circuit Breaker	218
7.5. Front Panel Touchscreen/Display Interface	219
7.5.1. LVDS Transmitter Board.....	219
7.5.2. Front Panel Touchscreen/Display Interface PCA.....	219
7.6. Software Operation	220
7.6.1. Adaptive Filter.....	220
7.6.2. Calibration - Slope and Offset.....	221
7.6.3. Measurement Algorithm.....	221
7.6.4. Temperature and Pressure Compensation	222
7.6.5. Internal Data Acquisition System (DAS)	222
8. TROUBLESHOOTING AND SERVICE	223
8.1. General Troubleshooting Hints.....	223
8.1.1. Interpreting WARNING Messages	224
8.1.2. Fault Diagnosis with TEST Functions	228
8.1.3. Using the Diagnostic Signal I/O Function	230
8.1.4. Internal Electronic Status LEDs	231
8.2. Gas Flow Problems	235
8.2.1. T360 Internal Gas Flow Diagrams	236
8.2.2. Typical Sample Gas Flow Problems	238
8.2.3. Poor or Stopped Flow of Purge Gas	240
8.3. Calibration Problems.....	241
8.3.1. Miscalibrated.....	241
8.3.2. Non-Repeatable Zero and Span.....	242
8.3.3. Inability to Span – Touchscreen SPAN Button Not Visible	242
8.3.4. Inability to Zero – Touchscreen ZERO Button Not Visible	243
8.4. Other Performance Problems.....	244
8.4.1. Temperature Problems	244
8.4.2. Excessive Noise	246
8.5. Subsystem Checkout	247
8.5.1. AC Mains Configuration.....	247
8.5.2. DC Power Supply	247
8.5.3. I ² C Bus.....	248
8.5.4. Touchscreen Interface	248
8.5.5. LCD Display Module.....	249
8.5.6. Relay Board	249
8.5.7. Sensor Assembly.....	249
8.5.8. Motherboard	252
8.5.9. CPU	254
8.5.10. RS-232 Communications	255
8.6. Repair Procedures	256
8.6.1. Repairing Sample Flow Control Assembly.....	256

8.6.2. Removing/Replacing the GFC Wheel	257
8.6.3. Disk-On-Module Replacement Procedure	259
8.7. Frequently Asked Questions	260
9. A PRIMER ON ELECTRO-STATIC DISCHARGE.....	263
9.1. How Static Charges are Created.....	263
9.2. How Electro-Static Charges Cause Damage	264
9.3. Common Myths About ESD Damage	265
9.4. Basic Principles of Static Control.....	266
9.4.1. General Rules.....	266
9.4.2. Basic anti-ESD Procedures for Analyzer Repair and Maintenance	268

LIST OF APPENDICES

APPENDIX A - SOFTWARE DOCUMENTATION

APPENDIX B - SPARE PARTS LIST

APPENDIX C - REPAIR QUESTIONNAIRE

APPENDIX D - ELECTRONIC SCHEMATICS

LIST OF FIGURES

Figure 3-1:	Front Panel Layout	27
Figure 3-2:	Display Screen and Touch Control	28
Figure 3-3:	Display/Touch Control Screen Mapped to Menu Charts.....	30
Figure 3-4:	Rear Panel Layout.....	31
Figure 3-5:	Internal Chassis Layout.....	33
Figure 3-6:	Optical Bench Layout	34
Figure 3-7:	Analog In Connector.....	36
Figure 3-8:	Current Loop Option Installed on the Motherboard.....	39
Figure 3-9:	Control Inputs Power Connections.....	41
Figure 3-10:	Alarm Relay Output Pin Assignments	42
Figure 3-11:	Basic Internal Gas Flow	45
Figure 3-12:	Pneumatic Connections–Basic Configuration–Using Bottled Span Gas	46
Figure 3-13:	Pneumatic Connections–Basic Configuration–Using Gas Dilution Calibrator	46
Figure 3-14:	Pneumatic Connections with Ambient Zero/Ambient Span Valves (OPT 50A)	48
Figure 3-15:	Pneumatic Connections with Ambient Zero/Ambient Span Valves (Opt 50A) and External Zero Air Scrubber.....	48
Figure 3-16:	Internal Pneumatic Flow – Ambient Zero/Ambient Span	49
Figure 3-17:	Pneumatic Connections with Ambient Zero/Pressurized Span Valves (OPT 50B)	50
Figure 3-18:	Pneumatic Connections with Ambient Zero/Pressurized Span Valves (Opt 50B) and External Zero Air Scrubber.....	51
Figure 3-19:	Internal Pneumatic Flow – Ambient Zero/Pressurized Span Valves.....	52
Figure 3-20:	Example of Pneumatic Set up for Multipoint Calibration.....	53
Figure 3-21:	O2 Sensor Calibration Set Up	61
Figure 3-22:	Internal Pneumatics with O2 Sensor Option 65	62
Figure 4-1:	Front Panel Display	67
Figure 4-2:	Viewing TEST Functions	70
Figure 4-3:	Viewing and Clearing T360 WARNING Messages	72
Figure 4-4:	Default DAS Channels Setup	80
Figure 4-5:	APICOM User Interface for DAS Configuration	94
Figure 4-6:	Analog Output Connector Pin Out.....	95
Figure 4-7:	Rear Panel Connector Pin-Outs for COM1 & COM2 in RS-232 Mode.....	109
Figure 4-8:	CPU Connector Pin-Outs for COM1 & COM2 in RS-232 Mode	110
Figure 4-9:	Jumper and Cables for Multidrop Mode	123
Figure 4-10:	RS-232-Multidrop Host-to-Analyzer Interconnect Diagram.....	124
Figure 4-11:	Setup for Calibrating Analog Voltage Outputs	141
Figure 4-12:	Setup for Calibrating Current Outputs	142
Figure 4-13:	Status Output Connector.....	152
Figure 4-14:	Control Inputs	154
Figure 4-15:	APICOM Remote Control Program Interface	161
Figure 5-1:	Pneumatic Connections–Basic Configuration–Using Bottled Span Gas	170
Figure 5-2:	Pneumatic Connections–Basic Configuration–Using Gas Dilution Calibrator	171
Figure 5-3:	Pneumatic Connections – Ambient Zero/Pressurized Span Valves	174
Figure 5-4:	Pneumatic Connections – Ambient Zero/Pressurized Span Valves and External Zero Air Scrubber	174
Figure 5-5:	Pneumatic Connections – Ambient Zero/Ambient Span Valves	175
Figure 5-6:	Pneumatic Connections – Ambient Zero/Ambient Span Valves with External Zero Air Scrubber	175
Figure 6-1:	Sample Particulate Filter Assembly	190
Figure 7-1:	Measurement Fundamentals.....	194
Figure 7-2:	GFC Wheel.....	194
Figure 7-3:	Measurement Fundamentals with GFC Wheel	195
Figure 7-4:	Affect of CO2 in the Sample on CO2 MEAS & CO2 REF	196
Figure 7-5:	Effects of Interfering Gas on CO2 MEAS & CO2 REF.....	197

Figure 7-6:	Chopped IR Signal	197
Figure 7-7:	Oxygen Sensor - Principle of Operation.....	199
Figure 7-8:	Internal Pneumatic Flow – Basic Configuration	200
Figure 7-9:	Flow Control Assembly & Critical Flow Orifice	201
Figure 7-10:	Gas Flow with O2 Sensor Option	203
Figure 7-11:	T360 Electronic Block Diagram	205
Figure 7-12:	CPU Board	206
Figure 7-13:	GFC Light Mask	208
Figure 7-14:	Segment Sensor and M/R Sensor Output.....	209
Figure 7-15:	T360 Sync / Demod Block Diagram	210
Figure 7-16:	Sample & Hold Timing.....	211
Figure 7-17:	Location of relay board Status LED's.....	214
Figure 7-18:	Power Distribution Block Diagram.....	218
Figure 7-19:	Front Panel and Display Interface Block Diagram	219
Figure 7-20:	Basic Software Operation.....	220
Figure 8-1:	Viewing and Clearing Warning Messages	226
Figure 8-2:	Example of Signal I/O Function.....	231
Figure 8-3:	CPU Status Indicator.....	232
Figure 8-4:	Sync/Demod Board Status LED Locations	233
Figure 8-5:	Relay Board Status LEDs.....	233
Figure 8-6:	T360 – Basic Internal Gas Flow	236
Figure 8-7:	Internal Pneumatic Flow – Ambient Zero/Pressurized Span Valves.....	237
Figure 8-8:	Internal Pneumatic Flow – Ambient Zero/Ambient Span	237
Figure 8-9:	T360 – Internal Pneumatics with O ₂ Sensor Option 65A	238
Figure 8-10:	Critical Flow Restrictor Assembly Disassembly	257
Figure 8-11:	Opening the GFC Wheel Housing.....	258
Figure 8-12:	Removing the GFC Wheel	258
Figure 9-1:	Triboelectric Charging	263
Figure 9-2:	Basic anti-ESD Work Station.....	266

LIST OF TABLES

Table 2-1:	Model T360 Basic Unit Specifications	21
Table 2-2:	Model T360M Basic Unit Specifications	22
Table 3-1:	Display and Touchscreen Control Description	29
Table 3-2:	Rear Panel Description	32
Table 3-3:	Analog Input Pin Assignments	36
Table 3-4:	T360 Analog Output Pin Outs	37
Table 3-5:	Status Output Pin-outs	38
Table 3-6:	Control Input Pin-outs.....	41
Table 3-8:	Concentration Alarm Relay Output Operation.....	42
Table 3-9:	Ambient Zero/Ambient Span Valve Operating States.....	49
Table 3-10:	Ambient Zero/Pressurized Span Valve Operating States	52
Table 3-11:	Front Panel Display During System Warm-Up.....	55
Table 3-12:	Possible Warning Messages at Start-Up	56
Table 4-1:	Analyzer Operating Modes.....	68
Table 4-2:	Test Functions Defined	69
Table 4-3:	List of Warning Messages.....	71
Table 4-4:	Primary Setup Mode Features and Functions.....	73
Table 4-5:	Secondary Setup Mode Features and Functions.....	73
Table 4-6:	Secondary Setup Mode Features and Functions.....	75
Table 4-7:	DAS Data Channel Properties.....	76
Table 4-8:	DAS Data Parameter Functions	77
Table 6-9:	Password Levels	103
Table 4-9:	Com Port Communication Modes	112

Table 4-10: Ethernet Status Indicators	114
Table 4-11: LAN/Internet Configuration Properties.....	115
Table 4-12: Internet Configuration Touchscreen Functions.....	119
Table 4-13: Variable Names (VARS).....	129
Table 4-14: T360 Diagnostic (DIAG) Functions	131
Table 4-15: DIAG - Analog I/O Functions	135
Table 4-16: Analog Output Voltage Ranges	135
Table 4-17: Analog Output Current Loop Range	136
Table 4-18: Analog Output Pin Assignments	136
Table 4-19: Voltage Tolerances for Analog Output Calibration	140
Table 4-20: Current Loop Output Calibration with Resistor	143
Table 4-21: Test Parameters Available for Analog Output A4.....	150
Table 4-22: CO2 Concentration Alarm Default Settings	151
Table 4-23: Status Output Pin Assignments.....	153
Table 4-24: Control Input Pin Assignments	154
Table 4-25: Terminal Mode Software Commands	155
Table 4-26: Command Types	156
Table 4-27: Serial Interface Documents	161
Table 4-28: RS-232 Com Parameters for Hessen Protocol.....	162
Table 4-29: Teledyne API Hessen Protocol Response Modes.....	165
Table 4-30: Default Hessen Status Bit Assignments	166
Table 5-1: AUTOCAL Modes	180
Table 5-2: AutoCal ATTRIBUTE Setup Parameters.....	180
Table 5-3 : Calibration Data Quality Evaluation	184
Table 6-1: T360 Maintenance Schedule	187
Table 6-2: T360 Test Function Record	188
Table 6-3: Predictive Uses for Test Functions	189
Table 7-1: Sync/Demod Status LED Activity.....	212
Table 7-2: Relay Board Status LED's	214
Table 8-1: Warning Messages - Indicated Failures	227
Table 8-2: Test Functions - Indicated Failures.....	229
Table 8-3: Sync/Demod Board Status Failure Indications	232
Table 8-4: I2C Status LED Failure Indications.....	233
Table 8-5: Relay Board Status LED Failure Indications	234
Table 8-6: DC Power Test Point and Wiring Color Codes.....	247
Table 8-7: DC Power Supply Acceptable Levels	248
Table 8-8: Relay Board Control Devices.....	249
Table 8-9: Opto Pickup Board Nominal Output Frequencies.....	250
Table 8-10: Analog Output Test Function - Nominal Values Voltage Outputs	252
Table 8-11: Analog Output Test Function - Nominal Values Current Outputs.....	253
Table 8-12: Status Outputs Check.....	253
Table 9-1: Static Generation Voltages for Typical Activities	264
Table 9-2: Sensitivity of Electronic Devices to Damage by ESD	264

This page intentionally left blank.

1. INTRODUCTION

The Models T360 and T360M differ only in specifications; unless clearly differentiated, both models in this manual are referred to as the T360 for simplification. The T360/T360M measures carbon dioxide CO₂ by comparing infrared energy absorbed by a sample to that absorbed by a reference according to the Beer-Lambert law. This is accomplished by using a Gas Filter Wheel which alternately allows a high energy infrared (IR) light source to pass through a CO₂ filled chamber and a chamber with no CO₂ present.

The IR light then travels through the sample cell, which has a folded path. Energy loss through the sample cell is compared with the zero reference signal provided by the gas filter to produce an output proportional to concentration, with little effect from interfering gases within the sample. A nitrogen purge system is provided for the GFC wheel assembly to eliminate the effects of ambient CO₂, if necessary.

This design produces superior zero and span stability and a high signal-to-noise ratio, allowing excellent sensitivity. Multi-tasking software gives real time indication of numerous operating parameters and provides automatic alarms if diagnostic limits are exceeded.

1.1. FEATURES

The Models T360 and T360M include the following features:

- Ranges, T360: 0-2 ppm to 0-2000 ppm, T360M: 0-4 ppm to 0-4000 ppm, user selectable
- Gas Filter Wheel for CO₂ specific measurement
- LCD Graphical User Interface with capacitive touch screen
- Multi-tasking software allows viewing of test variables during operation
- Continuous self checking with alarms
- Bi-directional RS-232 and 10/100Base-T Ethernet (optional USB and RS-485) ports for remote operation
- Front panel USB ports for peripheral devices
- Digital status outputs to indicate instrument operating condition
- Adaptive signal filtering to optimize response time
- Temperature & Pressure compensation
- Internal data logging with 1 min to 24 hour averages

1.2. USING THIS MANUAL

The flowcharts in this manual contain typical representations of the analyzer's display during the various operations being described. These representations are not intended to be exact and may differ slightly from the actual display of your instrument.

1.3. OPTIONS

Option	Option Number	Description/Notes
Pumps		Pumps meet all typical AC power supply standards while exhibiting same pneumatic performance.
	11	No pump (If one is standard either internal or external)
	10A	External Pump 100V – 120V/60Hz
	10B	External Pump 220V – 240V/50H
	10C	External Pump 220V – 240V/60Hz
	10D	External Pump 100V – 120V/50Hz
	10E	External Pump 100V /60Hz
	13	High Voltage Internal Pump 240V/50Hz
Rack Mount Kits		Options for mounting the analyzer in standard 19” racks
	20A	Rack mount brackets with 26 in. (660 mm) chassis slides
	20B	Rack mount brackets with 24 in. (610 mm) chassis slides
	21	Rack mount brackets only (compatible with carrying strap, Option 29)
	23	Rack mount for external pump pack (no slides)
Carrying Strap/Handle		Side-mounted strap for hand-carrying analyzer
	29	Extends from “flat” position to accommodate hand for carrying. Recesses to 9mm (3/8”) dimension for storage. Can be used with rack mount brackets, Option 21. Cannot be used with rack mount slides.
		 <p>CAUTION – GENERAL SAFETY HAZARD</p> <p>THE T360 OR T360M ANALYZER WEIGHS ABOUT 18 KG (40 POUNDS).</p> <p>TO AVOID PERSONAL INJURY WE RECOMMEND THAT TWO PERSONS LIFT AND CARRY THE ANALYZER. DISCONNECT ALL CABLES AND TUBING FROM THE ANALYZER BEFORE MOVING IT.</p>
Analog Input and USB port		Used for connecting external voltage signals from other instrumentation (such as meteorological instruments).
	64B	Also can be used for logging these signals in the analyzer’s internal DAS
Current Loop Analog Outputs		Adds isolated, voltage-to-current conversion circuitry to the analyzer’s analog outputs.
	41	Can be configured for any output range between 0 and 20 mA. May be ordered separately for any of the analog outputs. Can be installed at the factory or retrofitted in the field.
Parts Kits		Spare parts and expendables
	42A	Expendables Kit for analyzer includes a recommended set of expendables for one year of operation.
	43	Expendables Kit for Internal Zero/Span, one year of operation.
Calibration Valves		Used to control the flow of calibration gases generated from external sources, rather than manually switching the rear panel pneumatic connections.
	50A	AMBIENT ZERO AND AMBIENT SPAN VALVES Zero Air and Span Gas input supplied at ambient pressure. Gases controlled by 2 internal valves; SAMPLE/CAL & ZERO/SPAN.
	50B	AMBIENT ZERO AND PRESSURIZED SPAN VALVES Zero Air supplied at ambient pressure. Span gas supplied from pressurized bottle of cal gas.

Option	Option Number	Description/Notes										
Communication Cables		For remote serial, network and Internet communication with the analyzer.										
		<table border="1"> <thead> <tr> <th>Type</th> <th>Description</th> </tr> </thead> <tbody> <tr> <td>60A</td> <td>RS-232 Shielded, straight-through DB-9F to DB-25M cable, about 1.8 m long. Used to interface with older computers or code activated switches with DB-25 serial connectors.</td> </tr> <tr> <td>60B</td> <td>RS-232 Shielded, straight-through DB-9F to DB-9F cable of about 1.8 m length.</td> </tr> <tr> <td>60C</td> <td>Ethernet Patch cable, 2 meters long, used for Internet and LAN communications.</td> </tr> <tr> <td>60D</td> <td>USB Cable for direct connection between instrument (rear panel USB port) and personal computer.</td> </tr> </tbody> </table>	Type	Description	60A	RS-232 Shielded, straight-through DB-9F to DB-25M cable, about 1.8 m long. Used to interface with older computers or code activated switches with DB-25 serial connectors.	60B	RS-232 Shielded, straight-through DB-9F to DB-9F cable of about 1.8 m length.	60C	Ethernet Patch cable, 2 meters long, used for Internet and LAN communications.	60D	USB Cable for direct connection between instrument (rear panel USB port) and personal computer.
Type	Description											
60A	RS-232 Shielded, straight-through DB-9F to DB-25M cable, about 1.8 m long. Used to interface with older computers or code activated switches with DB-25 serial connectors.											
60B	RS-232 Shielded, straight-through DB-9F to DB-9F cable of about 1.8 m length.											
60C	Ethernet Patch cable, 2 meters long, used for Internet and LAN communications.											
60D	USB Cable for direct connection between instrument (rear panel USB port) and personal computer.											
USB Port		For remote connection										
	64A	For connection to personal computer. (Separate option only when Option 64B, <i>Analog Input and USB Com Port</i> , not elected).										
Concentration Alarm Relays		Issues warning when gas concentration exceeds limits set by user.										
	61	Four (4) "dry contact" relays on the rear panel of the instrument. This relay option is different from and in addition to the "Contact Closures" that come standard on all TAPI instruments.										
RS-232 Multidrop		Enables communications between host computer and up to eight analyzers.										
	62	Multidrop card seated on the analyzer's CPU card. Each instrument in the multidrop network requires this card and a communications cable (Option 60B).										
Other Gas Options		Second gas sensor and gas conditioners										
	65A	Oxygen (O ₂) Sensor										
Special Features		Built in features, software activated										
	N/A	Maintenance Mode Switch , located inside the instrument, places the analyzer in maintenance mode where it can continue sampling, yet ignore calibration, diagnostic, and reset instrument commands. This feature is of particular use for instruments connected to Multidrop or Hessen protocol networks. Call Customer Service for activation.										
	N/A	Second Language Switch activates an alternate set of display messages in a language other than the instrument's default language. Call Customer Service for a specially programmed Disk on Module containing the second language.										
	N/A	Dilution Ratio Option allows the user to compensate for diluted sample gas, such as in continuous emission monitoring (CEM) where the quality of gas in a smoke stack is being tested and the sampling method used to remove the gas from the stack dilutes the gas. Call Customer Service for activation.										

This page intentionally left blank.

2. SPECIFICATIONS AND APPROVALS

2.1. SPECIFICATIONS

Table 2-1: Model T360 Basic Unit Specifications

T360 Parameter	T360 Specification
Ranges (Physical Analog Output)	Min: 0-2 ppm Full scale Max: 0-2,000 ppm Full scale Selectable, dual ranges and auto ranging supported
Measurement Units	ppb, ppm, $\mu\text{g}/\text{m}^3$, mg/m^3 , % (user selectable)
Zero Noise	< 0.1 ppm (RMS)
Span Noise	< 1% of reading (RMS)
Lower Detectable Limit	< 0.2 ppm ¹
Zero Drift (24 hours)	<0.25 ppm ¹
Span Drift (24 hours)	<0.5% of reading ¹
Lag Time	10 seconds
Rise/Fall Time	<60 seconds to 95%
Linearity	1% of full scale
Precision	0.5% of reading
Sample Flow Rate	800cm ³ /min. $\pm 10\%$ O ₂ Sensor option adds 110 cm ³ /min, $\pm 20\%$, to total flow through when installed.
Temperature Coefficient	< 0.1% of Full Scale per °C
Voltage Coefficient	< 0.05% of Full Scale per V
AC Power Rating	100V-120V, 60 Hz, (142 W) ; 220V – 240 V, 50 Hz (147 W)
Analog Output Ranges	10V, 5V, 1V, 0.1V (selectable)
Analog Output Resolution	1 part in 4096 of selected full-scale voltage
Recorder Offset	$\pm 10\%$
Standard I/O	1 Ethernet: 10/100Base-T 2 RS-232 (300 – 115,200 baud) 2 USB device ports 8 opto-isolated digital status outputs 6 opto-isolated digital control inputs (3 defined, 3 spare) 4 analog outputs
Optional I/O	1 USB com port 1 RS485 8 analog inputs (0-10V, 12-bit) 4 digital alarm outputs Multidrop RS232 3 4-20mA current outputs
Environmental	Installation category (over-voltage category) II; Pollution degree 2
Temperature Range	5-40°C
Humidity Range	0 - 95% RH, non-condensing
Dimensions H x W x D	7" x 17" x 23.5" (178 mm x 432 mm x 597 mm)
Weight	40 lbs. (18.1 kg)
¹ At constant temperature and voltage.	

Table 2-2: Model T360M Basic Unit Specifications

T360M Parameter	T360M Specification
Ranges (Physical Analog Output)	Min: 0-4 ppm Full scale Max: 0-4000 ppm Full scale Selectable, dual ranges and auto ranging supported
Measurement Units	ppb, ppm, $\mu\text{g}/\text{m}^3$, mg/m^3 , (selectable)
Zero Noise	< 0.2 ppm (RMS)
Span Noise	< 1% of reading (RMS)
Lower Detectable Limit	< 0.4 ppm ¹
Zero Drift (24 hours)	<0.5 ppm ¹
Span Drift (24 hours)	<0.5% of reading ¹
Lag Time	10 seconds
Rise/Fall Time	<60 seconds to 95%
Linearity	1% of full scale
Precision	0.5% of reading
Sample Flow Rate	800cm ³ /min. $\pm 10\%$ O ₂ Sensor option adds 110 cm ³ /min, $\pm 20\%$, to total flow though when installed
Temperature Coefficient	< 0.1% of Full Scale per °C or 0.1 ppm per °C, whichever is greater
Voltage Coefficient	< 0.05% of Full Scale per V
AC Power Requirements	100V – 120V, 220V – 240V, 50/60 Hz
Analog Output Ranges	10V, 5V, 1V, 0.1V
Recorder Offset	$\pm 10\%$
Analog Output Resolution	1 part in 4096 of selected full-scale voltage
Standard I/O	1 Ethernet: 10/100Base-T 2 RS232 (300-115,200 baud) 2 USB device ports 8 Status opto-isolated digital status outputs 6 Opto-isolated digital control inputs (3 defined, 3 spare) 4 Analog outputs
Optional I/O	1 USB com port 1 RS485 8 Analog inputs (0-10V, 12-bit) 4 Digital alarm outputs Multidrop RS232 3 4-20mA current outputs
Operating Temperature Range	5-40°C
Humidity Range	0 - 95% RH, non-condensing
Dimensions H x W x D	7" x 17" x 23.5" (178 mm x 432 mm x 597 mm)
Weight	40 lbs. (18.1 kg)
Environmental	Installation category (over-voltage category) II; Pollution degree 2
¹ At constant temperature and voltage.	

2.2. APPROVALS AND CERTIFICATIONS

The Teledyne Instruments Model T360 Gas Filter Correlation CO₂ Analyzer was tested and certified for Safety and Electromagnetic Compatibility (EMC). This section presents the compliance statements for those requirements and directives.

2.2.1. Safety

IEC 61010-1:2001, Safety requirements for electrical equipment for measurement, control, and laboratory use.

CE: 2006/95/EC, Low-Voltage Directive

North American:

cNEMKO (Canada): CAN/CSA-C22.2 No. 61010-1-04

NEMKO-CCL (US): UL No. 61010-1 (2nd Edition)

2.2.2. EMC

EN 61326-1 (IEC 61326-1), Class A Emissions/Industrial Immunity

EN 55011 (CISPR 11), Group 1, Class A Emissions

FCC 47 CFR Part 15B, Class A Emissions

CE: 2004/108/EC, Electromagnetic Compatibility Directive

This page intentionally left blank.

3. GETTING STARTED

3.1. UNPACKING AND INITIAL SET UP



CAUTION

To avoid personal injury, always use two persons to lift and carry the Model T360.



WARNING

Never disconnect PCAs, wiring harnesses or electronic subassemblies while the instrument is under power.



CAUTION – Avoid Warranty Invalidation

Printed circuit assemblies (PCAs) are sensitive to electro-static discharges too small to be felt by the human nervous system. Damage resulting from failure to use ESD protection when working with electronic assemblies will void the instrument warranty.

See *A Primer on Electro-Static Discharge* in this manual for more information on preventing ESD damage.

NOTE

It is recommended that you store shipping containers/materials for future use if/when the instrument should be returned to the factory for repair and/or calibration service. See Warranty page in this manual and shipping procedures on our Website at:

<http://www.teledyne-api.com> under Customer Support > Return Authorization.

1. Verify that there is no apparent external shipping damage. If damage has occurred, please advise the shipper first, then Teledyne Instruments.
2. Included with your analyzer is a printed record of the final performance characterization performed on your instrument at the factory. This record, titled Final Test and Validation Data Sheet (P/N 04596) is an important quality assurance and calibration record for this instrument. It should be placed in the quality records file for this instrument.
3. Carefully remove the top cover of the analyzer and check for internal shipping damage.
 - Remove the set-screw located in the top, center of the Front panel.
 - Remove the 2 screws fastening the top cover to the unit (one per side towards the rear).
 - Slide the cover backwards until it clears the analyzer's front bezel.
 - Lift the cover straight up.

4. Inspect the interior of the instrument to make sure all circuit boards and other components are in good shape and properly seated.
5. Check the connectors of the various internal wiring harnesses and pneumatic hoses to make sure they are firmly and properly seated.
6. Verify that all of the optional hardware ordered with the unit has been installed. These are listed on the paperwork accompanying the analyzer.
7. **VENTILATION CLEARANCE:** Whether the analyzer is set up on a bench or installed into an instrument rack, be sure to leave sufficient ventilation clearance.

AREA	MINIMUM REQUIRED CLEARANCE
Back of the instrument	4 in.
Sides of the instrument	1 in.
Above and below the instrument	1 in.

Various rack mount kits are available for this analyzer – please see Section 1.3.

3.2. FRONT PANEL

Figure 3-1 shows the analyzer's front panel layout, followed by a close-up of the display screen in Figure 3-2, which is described in Table 3-1. The two USB ports on the front panel are provided for the connection of peripheral devices:

- plug-in mouse (not included) to be used as an alternative to the touchscreen interface
- thumb drive (not included) to download updates to instruction software (contact TAPI Technical Support for information).

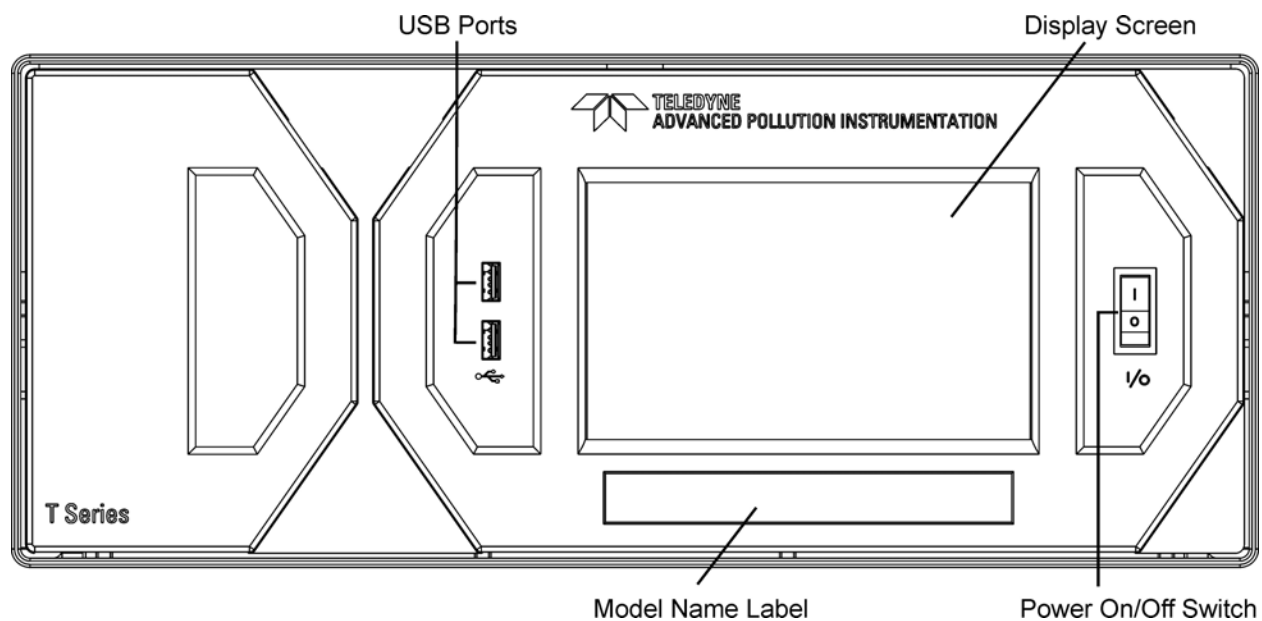

Figure 3-1: Front Panel Layout

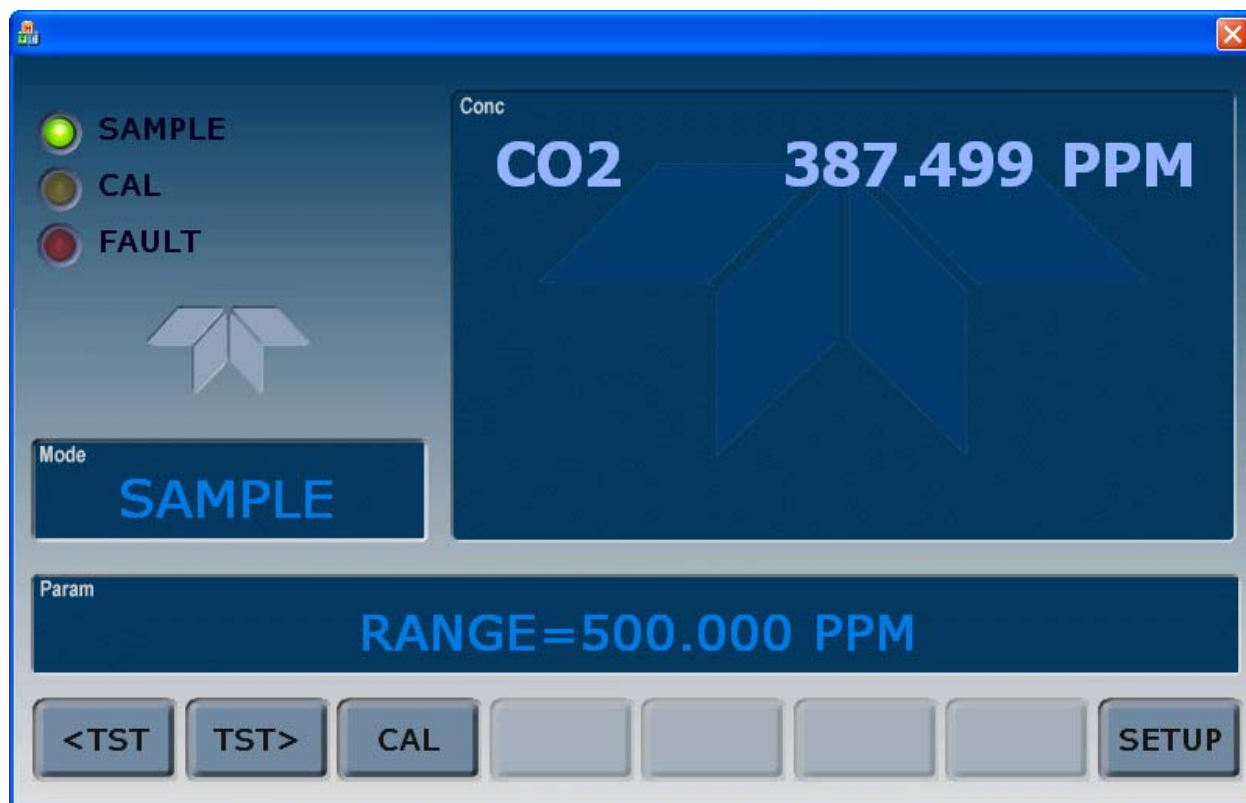

Figure 3-2: Display Screen and Touch Control



CAUTION – Avoid Damaging Touchscreen

Do not use hard-surfaced instruments such as pens to operate the touchscreen.

The front panel liquid crystal display includes touch control. Upon analyzer start-up, the display shows a splash screen and other initialization indicators before the main display appears, similar to Figure 3-2 above (may or may not display a Fault alarm). The LEDs on the display screen indicate the Sample, Calibration and Fault states; also on the screen is the gas concentration field (Conc), which displays real-time readouts for the primary gas and for the secondary gas if installed. The display screen also shows which mode the analyzer is currently in (Mode field), as well as messages and data (Param field). Along the bottom of the screen is a row of touch control buttons; only those that are currently applicable will have a label. Table 3-1 provides detailed information for each component of the screen.

Table 3-1: Display and Touchscreen Control Description

Field	Description/Function			
Status	LEDs indicating the states of Sample, Calibration and Fault, as follows:			
	Name	Color	State	Definition
	SAMPLE	Green	Off	Unit is not operating in sample mode, DAS is disabled.
			On	Sample Mode active; Front Panel Display being updated; DAS data being stored.
			Blinking	Unit is operating in sample mode, front panel display being updated, DAS hold-off mode is ON, DAS disabled
CAL	Yellow	Off	Auto Cal disabled	
		On	Auto Cal enabled	
		Blinking	Unit is in calibration mode	
FAULT	Red	Off	No warnings exist	
		Blinking	Warnings exist	
Conc	Displays the actual concentration of the sample gas currently being measured by the analyzer in the currently selected units of measure			
Mode	Displays the name of the analyzer's current operating mode			
Param	Displays a variety of informational messages such as warning messages, operational data, test function values and response messages during interactive tasks.			
Control Buttons	Displays dynamic, context sensitive labels on each button, which is blank when inactive until applicable.			

Figure 3-3 shows how the front panel display is mapped to the menu charts illustrated in this manual. The Mode, Param (parameters), and Conc (gas concentration) fields in the display screen are represented across the top row of each menu chart. The eight touchscreen control buttons along the bottom of the display screen are represented in the bottom row of each menu chart.

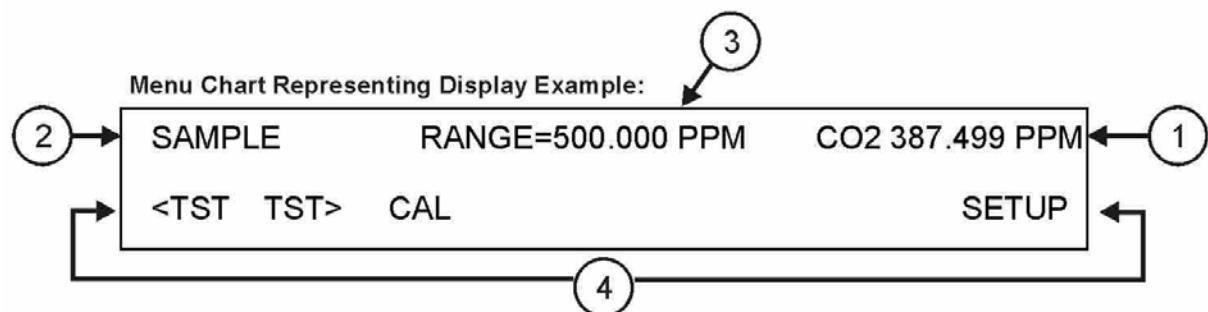
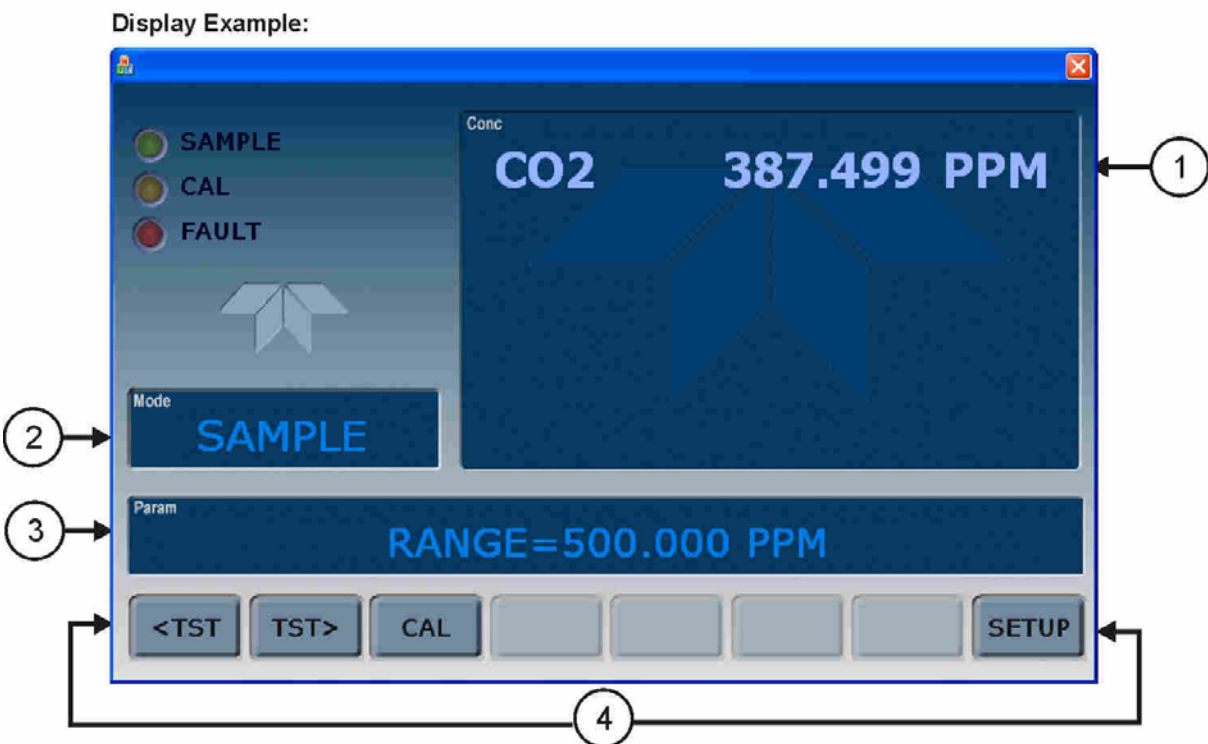
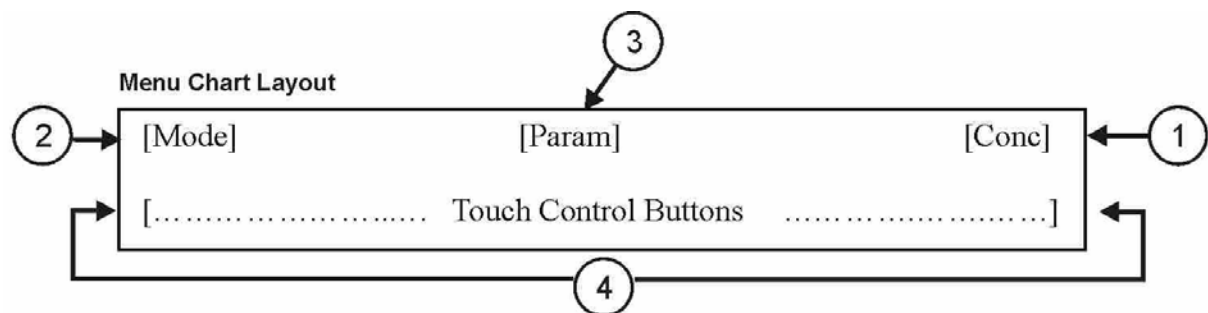

Figure 3-3: Display/Touch Control Screen Mapped to Menu Charts

3.3. REAR PANEL

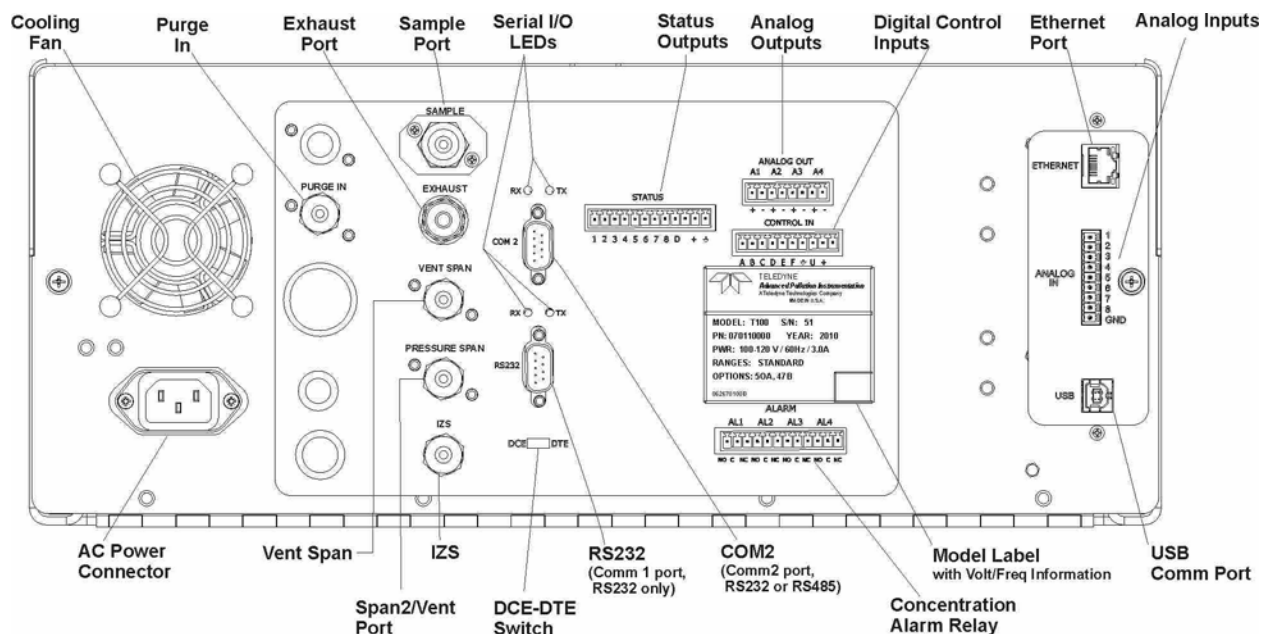



Figure 3-4: Rear Panel Layout

Table 3-2 provides a description of each component on the rear panel

Table 3-2: Rear Panel Description

Component	Function
cooling fan	Pulls ambient air into chassis through side vents and exhausts through rear
 AC power connector	Connector for three-prong cord to apply AC power to the analyzer CAUTION! The cord's power specifications (specs) MUST comply with the power specs on the analyzer's rear panel Model number label
Model/specs label	Identifies the analyzer model number and provides power specs
PURGE IN	Connect a source of dried air that has been scrubbed of CO ₂ . This inlet supplies purge air to the GFC wheel housing (Section 7.1.3.1). (Also see Section 8.2.3).
SAMPLE	Connect a gas line from the source of sample gas here. Calibration gases are also inlet here on units without zero/span valve options installed.
EXHAUST	Connect an exhaust gas line of not more than 10 meters long here that leads outside the shelter or immediate area surrounding the instrument.
VENT SPAN	Span gas vent outlet for units with zero/span valve options installed. Connect an exhaust gas line of not more than 10 meters long here.
PRESSURE SPAN	On units with zero/span valve options installed, connect a gas line to the source of calibrated span gas here.
IZS	Internal Zero Air: On units with zero/span valve options installed but no internal zero air scrubber, attach a gas line to the source of zero air here.
RX TX	LEDs indicate receive (RX) and transmit (TX) activity on the when blinking.
COM 2	Serial communications port for RS-232 or RS-485.
RS-232	Serial communications port for RS-232 only.
DCE DTE	Switch to select either data terminal equipment or data communication equipment during RS-232 communication.
STATUS	For outputs to devices such as Programmable Logic Controllers (PLCs).
ANALOG OUT	For voltage or current loop outputs to a strip chart recorder and/or a data logger.
CONTROL IN	For remotely activating the zero and span calibration modes.
ALARM	Option for concentration alarms and system warnings.
ETHERNET	Connector for network or Internet remote communication, using Ethernet cable.
ANALOG IN	Option for external voltage signals from other instrumentation and for logging these signals.
USB	Com port optional connector for direct connection to laptop computer, using USB cable.
Information Label	Includes voltage and frequency specifications.

3.4. INTERNAL LAYOUT

Figure 3-5 shows a top-down view of the analyzer.

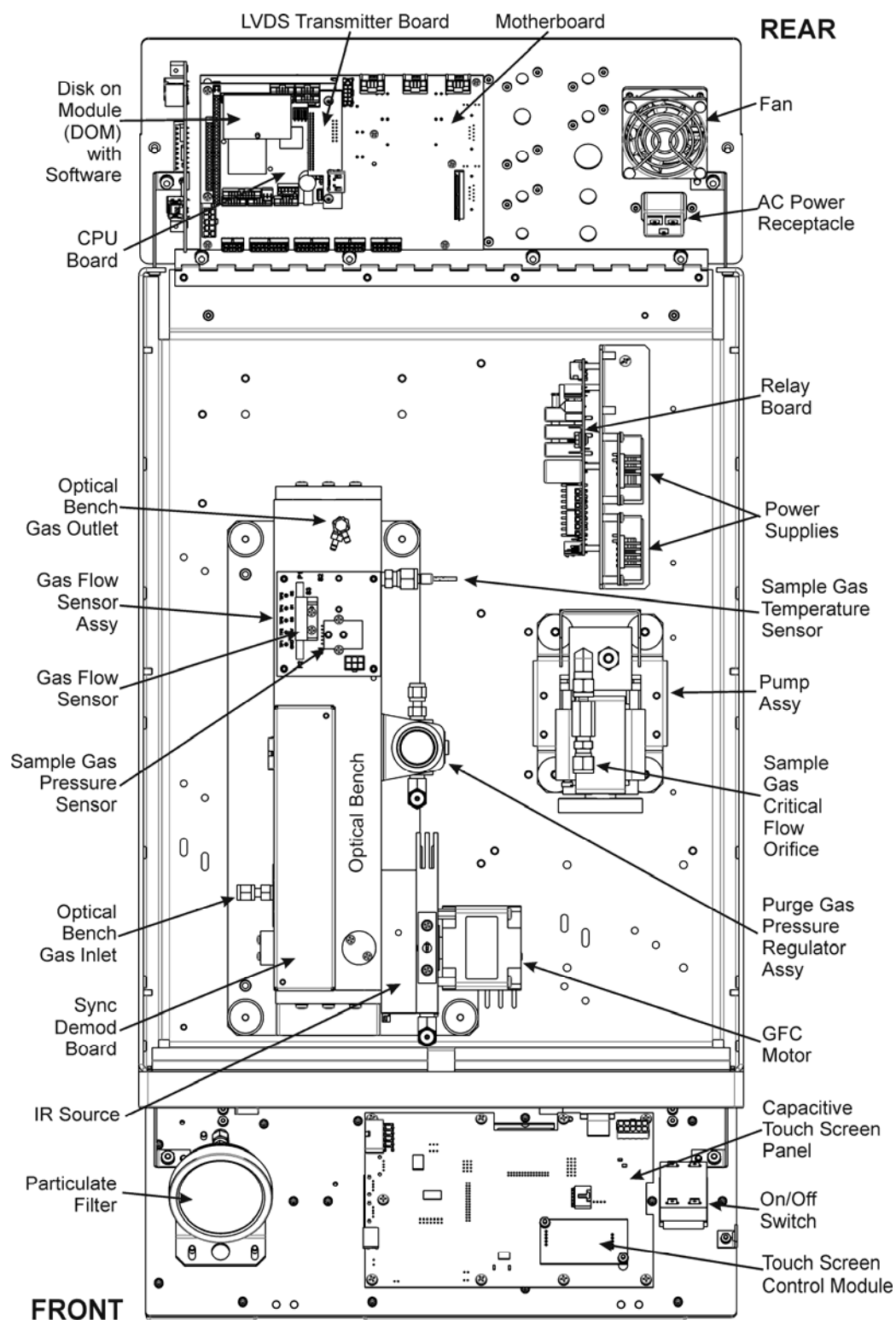

Figure 3-5: Internal Chassis Layout

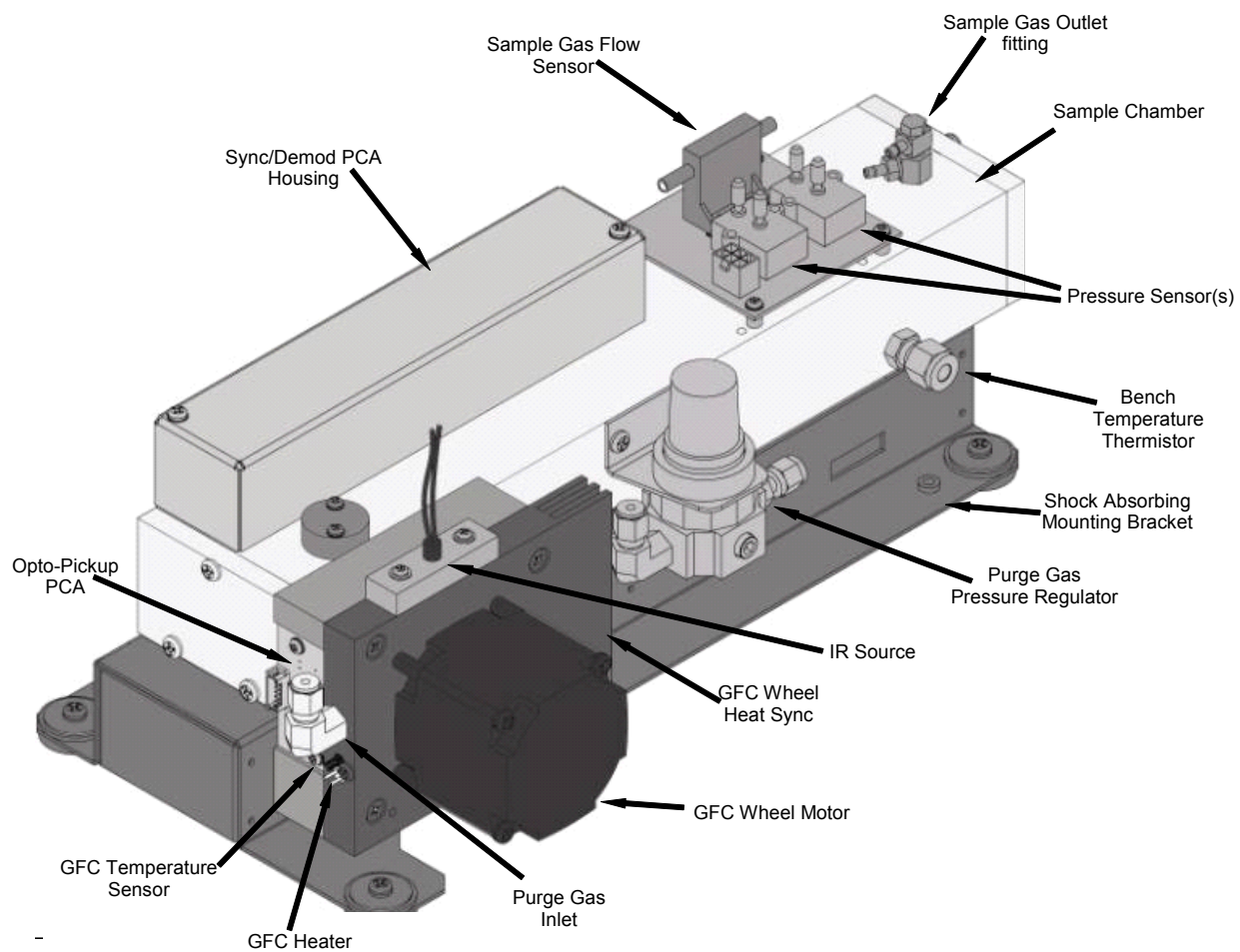

Figure 3-6: Optical Bench Layout

3.5. ELECTRICAL CONNECTIONS



WARNING

Never disconnect PCAs, wiring harnesses or electronic subassemblies while the instrument is under power.

NOTE

To maintain compliance with EMC standards, it is required that the cable length be no greater than 3 meters for all I/O connections, which include Analog In, Analog Out, Status Out, Control In, Ethernet/LAN, USB, RS-232, and RS-485.

Refer to Figure 3-4 for the locations of the rear panel connections.

3.5.1. Power Connection



WARNING

Power connection must have functioning ground connection.

Do not defeat the ground wire on power plug.

Turn off analyzer power before disconnecting or connecting electrical subassemblies.

Do not operate with cover off.



CAUTION

Check the voltage and frequency specifications on the rear panel Model Label for compatibility with the local power before plugging the analyzer into line power.

Do not plug in the power cord if the voltage or frequency is incorrect.

The T360 analyzer can be configured for both 100-130 V and 210-240 V at either 50 or 60 Hz. To avoid damage to your analyzer, make sure that the AC power voltage matches the voltage indicated on the rear panel serial number label and that the frequency is between 47 and 63 Hz.

Attach the power cord to the analyzer and plug it into a power outlet capable of carrying at least 10 A current at your AC voltage and that it is equipped with a functioning earth ground.

3.5.2. Connecting Analog Inputs (Option 64B)

The Analog In connector is used for connecting external voltage signals from other instrumentation (such as meteorological instruments) and for logging these signals in the analyzer's internal data acquisition system (DAS). The input voltage range for each analog input is 0-10 VDC, and the input impedance is nominally 20k Ω in parallel with 0.1 μ F.

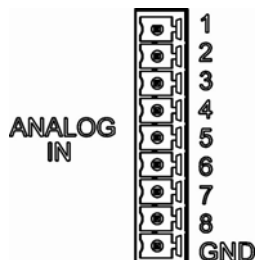

Figure 3-7: Analog In Connector

Pin assignments for the Analog In connector are presented in Table 3-3.

Table 3-3: Analog Input Pin Assignments

PIN	DESCRIPTION	DAS PARAMETER ¹
1	Analog input # 1	AIN 1
2	Analog input # 2	AIN 2
3	Analog input # 3	AIN 3
4	Analog input # 4	AIN 4
5	Analog input # 5	AIN 5
6	Analog input # 6	AIN 6
7	Analog input # 7	AIN 7
8	Analog input # 8	AIN 8
GND	Analog input Ground	N/A

¹ See Section 4.7 for details on setting up the DAS.

3.5.3. Connecting Analog Outputs

The T360 is equipped with several analog output channels accessible through a connector on the back panel of the instrument. The standard configuration for these outputs is mVDC. An optional current loop output is available for each.

When the instrument is in its default configuration, channels A1 and A2 output a signal that is proportional to the CO₂ concentration of the sample gas. Either can be used for connecting the analog output signal to a chart recorder or for interfacing with a data logger.

Output A3 is only used if the optional O₂ sensor is installed.

Channel A4 is special. It can be set by the user (see Section 4.13.9) to output any one of the parameters accessible through the <TST TST> menu (Table 4-2).

To access these signals attach a strip chart recorder and/or data-logger to the appropriate analog output connections on the rear panel of the analyzer.

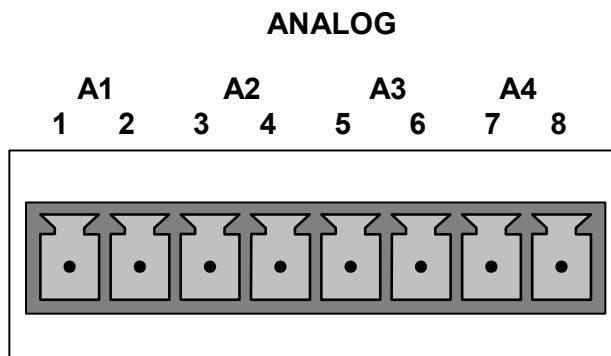

Pin-outs for the analog output connector at the rear panel of the instrument are:

Table 3-4: T360 Analog Output Pin Outs

PIN	ANALOG OUTPUT	VDC SIGNAL	MADC SIGNAL
1	A1	V Out	I Out +
2		Ground	I Out -
3	A2	V Out	I Out +
4		Ground	I Out -
5	A3 (Only used if O ₂ sensor is installed)	V Out	I Out +
6		Ground	I Out -
7	A4	V Out	Not used
8		Ground	Not used

- The default analog output voltage setting of the analyzer is 0 – 5 VDC with a range of 0 – 500 ppm.
- To change these settings, see Sections 4.13.4 and 4.8 respectively.

3.5.4. Connecting the Status Outputs

If you wish utilize the analyzer's status outputs to interface with a device that accepts logic-level digital inputs, such as programmable logic controllers (PLC's) they are accessed via a 12-pin connector on the analyzer's rear panel labeled STATUS.

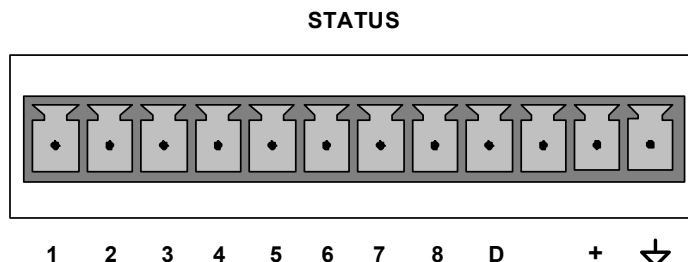

NOTE

Most PLC's have internal provisions for limiting the current the input will draw. When connecting to a unit that does not have this feature, external resistors must be used to limit the current through the individual transistor outputs to $\leq 50\text{mA}$ ($120\ \Omega$ for 5V supply).

The pin assignments for the status outputs can be found in the table below:

Table 3-5: Status Output Pin-outs

OUTPUT #	STATUS DEFINITION	CONDITION
1	SYSTEM OK	On if no faults are present.
2	CONC VALID	On if CO ₂ concentration measurement is valid. If the CO ₂ concentration measurement is invalid, this bit is OFF.
3	HIGH RANGE	On if unit is in high range of DUAL or AUTO range modes.
4	ZERO CAL	On whenever the instruments ZERO point is being calibrated.
5	SPAN CAL	On whenever the instruments SPAN point is being calibrated.
6	DIAG MODE	On whenever the instrument is in DIAGNOSTIC mode.
7	ALARM1	On whenever the measured CO ₂ concentration is above the set point for ALM1
8	ALARM2	On whenever the measured CO ₂ concentration is above the set point for ALM2
D	EMITTER BUS	The emitters of the transistors on pins 1-8 are bused together.
+	DC POWER	+ 5 VDC
⚡	Digital Ground	The ground level from the analyzer's internal DC power supplies.

3.5.5. Current Loop Analog Outputs (Option 41)

This option adds isolated, voltage-to-current conversion circuitry to the analyzer's analog outputs. This option may be ordered separately for any of the analog outputs; it can be installed at the factory or added later. Call TAPI sales for pricing and availability.

The current loop option can be configured for any output range between 0 and 20 mA. Figure 3-8 provides installation instructions and illustrates a sample combination of one current output and two voltage outputs configuration. Information on calibrating or adjusting these outputs can be found in Section 4.13.4.3.

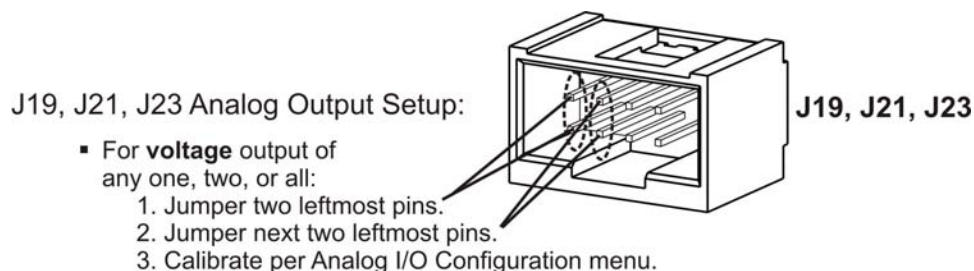

- For **current** output of any one, two, or all:
 1. Remove jumper shunts.
 2. Install Current Loop option.
 3. Calibrate per Analog I/O Configuration menu.

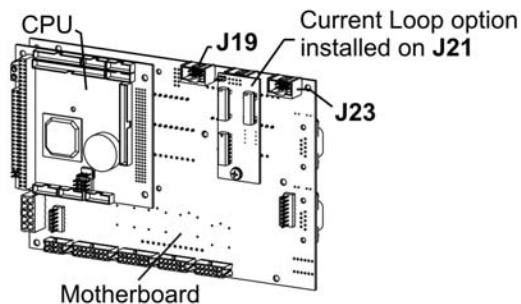

Example setup: install jumper shunts for voltage output on J19 and J23; remove jumper shunts and install Current Loop option for current output on J21.

Figure 3-8: Current Loop Option Installed on the Motherboard

3.5.5.1. CONVERTING CURRENT LOOP ANALOG OUTPUTS TO STANDARD VOLTAGE OUTPUTS

NOTE

Servicing or handling of circuit components requires electrostatic discharge protection, i.e. ESD grounding straps, mats and containers. Failure to use ESD protection when working with electronic assemblies will void the instrument warranty.

See Section 9 for more information on preventing ESD damage.

To convert an output configured for current loop operation to the standard 0 to 5 VDC output operation:

1. Turn off power to the analyzer.
2. If a recording device was connected to the output being modified, disconnect it.
3. Remove the top cover
 - Remove the set screw located in the top, center of the rear panel
 - Remove the screws fastening the top cover to the unit (four per side).
 - Slide the cover back and lift straight up .
4. Disconnect the current loop option PCA from the appropriate connector on the motherboard (see Figure 3-8).
5. Place a shunt between the leftmost two pins of the connector (see Figure 3-8).
6. Reattach the top case to the analyzer.
7. The analyzer is now ready to have a voltage-sensing, recording device attached to that output

3.5.6. Connecting the Control Inputs

If you wish to use the analyzer to remotely activate the zero and span calibration modes, several digital control inputs are provided through a 10-pin connector labeled CONTROL IN on the analyzer's rear panel.

There are two methods for energizing the control inputs. The internal +5V available from the pin labeled "+" is the most convenient method. However, if full isolation is required, an external 5 VDC power supply should be used.

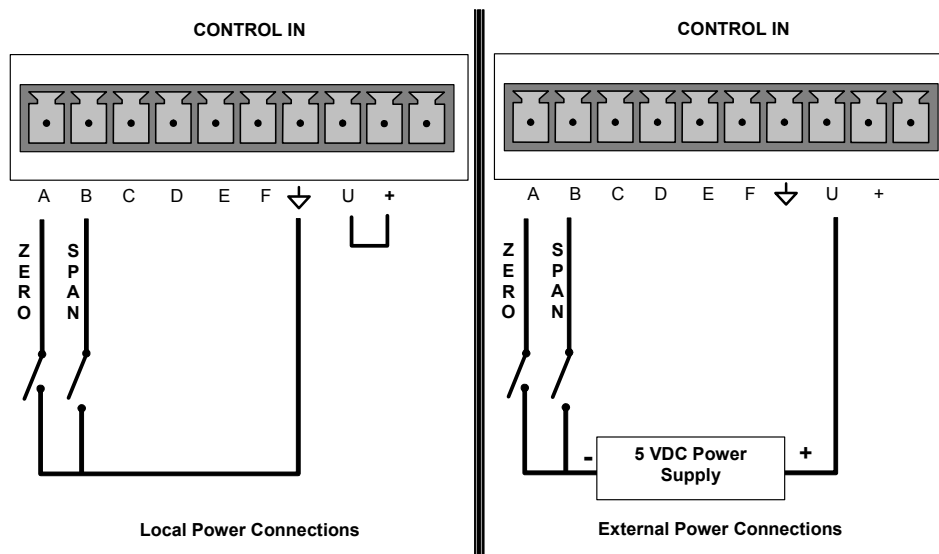

Figure 3-9: Control Inputs Power Connections

The pin assignments for the digital control inputs can be found in the table below:

Table 3-6: Control Input Pin-outs

INPUT #	STATUS DEFINITION	ON CONDITION
A	REMOTE ZERO CAL	The Analyzer is placed in Zero Calibration mode. The mode field of the display will read ZERO CAL R.
B	REMOTE SPAN CAL	The Analyzer is placed in Span Calibration mode. The mode field of the display will read SPAN CAL R.
C	SPARE	
D	SPARE	
E	SPARE	
F	SPARE	
▽	Digital Ground	May be connected to the ground of the data logger/recorder.
U	Pull-up supply for inputs	Input pin for +5 VDC required to activate pins A – F. This can be from an external source or from the “+” pin of the instruments STATUS connector.
+	Internal +5V Supply	Internal source of +5V which can be used to actuate control inputs when connected to the U pin.

3.5.7. Connecting the Alarm Relay Option (OPT 61)

Option 61 consists of a set of 2 concentration alarms. Each alarm can be independently enabled or disabled as well as programmed with its own, individual alarm limit point (see Section 4.14 for details on programming the alarms).

The status of each alarm is available via a set of alarm relay outputs located in the lower right quadrant of the analyzer’s rear panel (see Figure 3-4). While there are four relay outputs on the back of the analyzer, only two of the outputs correspond to the instrument’s two concentration alarms.

Table 3-7: Alarm Relay Output Assignments

RELAY NAME	AL1	AL2	AL3	AL4
ASSIGNED ALARM	ST_SYSTEM_OK2 ¹	CONCENTRATION ALARM 1	CONCENTRATION ALARM 2	SPARE

¹ ST_SYSTEM OK2 is a second system OK status alarm available on some analyzers.

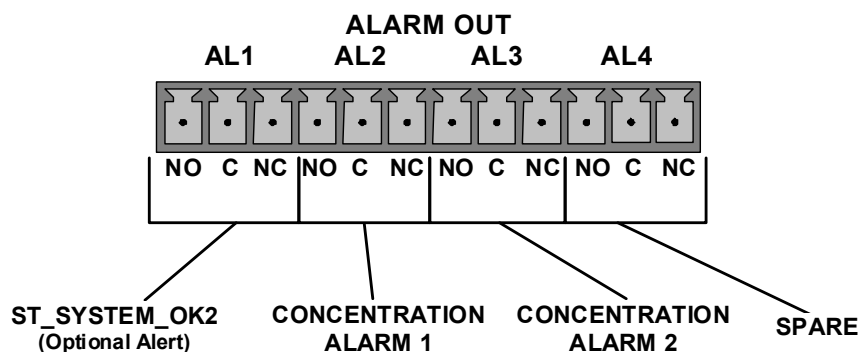

Figure 3-10: Alarm Relay Output Pin Assignments

Each of the two concentration relay outputs has 3-pin connections that allow the relay to be connected for either normally open or normally closed operation. Table 3-8 describes how to connect the alarm relays.

Table 3-8: Concentration Alarm Relay Output Operation

RELAY	FUNCTION	RELAY PIN STATE ¹			COMMENTS
		NO	C	NC	
AL2	Concentration Alarm 1 Active	●	●		Gas concentration level is above the trigger limit set for CONC_ALARM_1 • DAS Trigger CONCW1 ACTIVATED • CONC ALARM1 WARN appears on Analyzer Display
	Concentration Alarm 1 Inactive			●	Gas concentration level is below the trigger limit set for CONC_ALARM_1
AL3	Concentration Alarm 2 Active	●	●		Gas concentration level is above the trigger limit set for CONC_ALARM_2 • DAS Trigger CONCW2 ACTIVATED • CONC ALARM2 WARN appears on Analyzer Display
	Concentration Alarm 2 Inactive			●	Gas concentration level is below the trigger limit set for CONC_ALARM_2

¹ NO = Normally Open operation. C = Common. NC = Normally Closed operation.

3.5.8. Connecting the Communications Interfaces

For RS-232 or RS-485 (option) communications through the analyzer's serial interface com ports, refer to Section 4.11 of this manual for instructions on their configuration and usage.

3.5.8.1. CONNECTING TO A LAN OR THE INTERNET

For network or Internet communication with the analyzer, connect an Ethernet cable from the analyzer's rear panel Ethernet interface connector to an Ethernet access port.

NOTE

The T360 firmware supports dynamic IP addressing or DHCP. If your network also supports DHCP, the analyzer will automatically configure its LAN connection appropriately (Section 4.11.6.1).

If your network does not support DHCP, see Section 4.11.6.2 for instructions manually configuring the LAN connection. This is the recommended configuration.

3.5.8.2. CONNECTING TO A PERSONAL COMPUTER (PC)

If the USB port is configured for direct communication between the analyzer and a desktop or a laptop PC, connect a USB cable between the analyzer (rear panel) and the PC or laptop USB ports, and follow the set-up instructions in Section 4.11.7. (RS-485 communication is not available with the USB com port option)

3.5.8.3. CONNECTING TO A MULTIDROP NETWORK (OPTION 62)

The multidrop option is used with any of the RS-232 serial ports to enable communications of up to eight analyzers with the host computer over a chain of RS-232 cables via the instruments COM1 port (labeled **RS232**). It is subject to the distance limitations of the RS 232 standard.

For information on using and setting up this option (See Section 4.11.8).

3.6. PNEUMATIC CONNECTIONS



CAUTION!

Do not operate this instrument until you've removed dust plugs from SAMPLE and EXHAUST ports on the rear panel!

3.6.1. Basic Pneumatic Connections

NOTE

In order to prevent dust from getting into the gas flow channels of your analyzer, it was shipped with small plugs inserted into each of the pneumatic fittings on the back panel. Remove these plugs before operating the analyzer. It is recommended that they be stored for future use (moving, storing or shipping the analyzer).

Figure 3-11 illustrates the internal gas flow of the instrument in its basic configuration. Figure 3-13 illustrates the basic configuration for gas supply and exhaust lines to the Model T360 Analyzer.

Please refer to Figure 3-4 for pneumatic fittings at the rear panel and Table 3-2 for their descriptions.

NOTE

Sample and calibration gases should only come into contact with PTFE (Teflon), FEP, glass, stainless steel or brass.

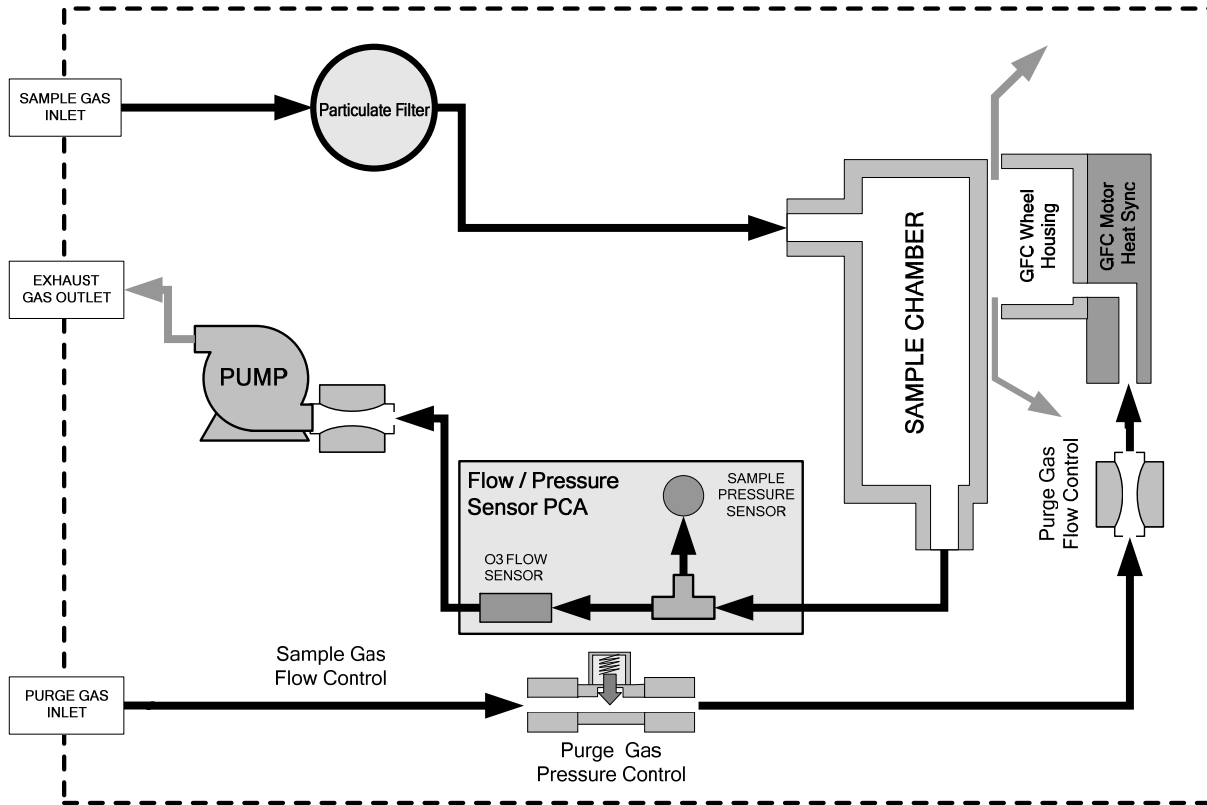

Figure 3-11: Basic Internal Gas Flow

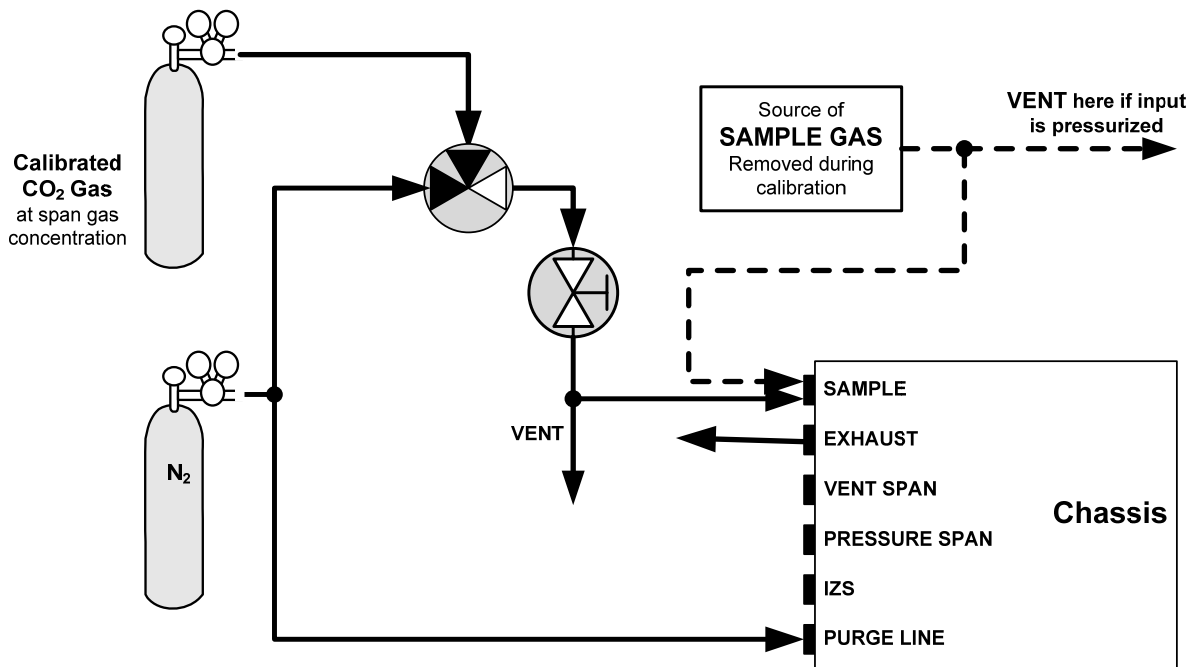

Figure 3-12: Pneumatic Connections–Basic Configuration–Using Bottled Span Gas

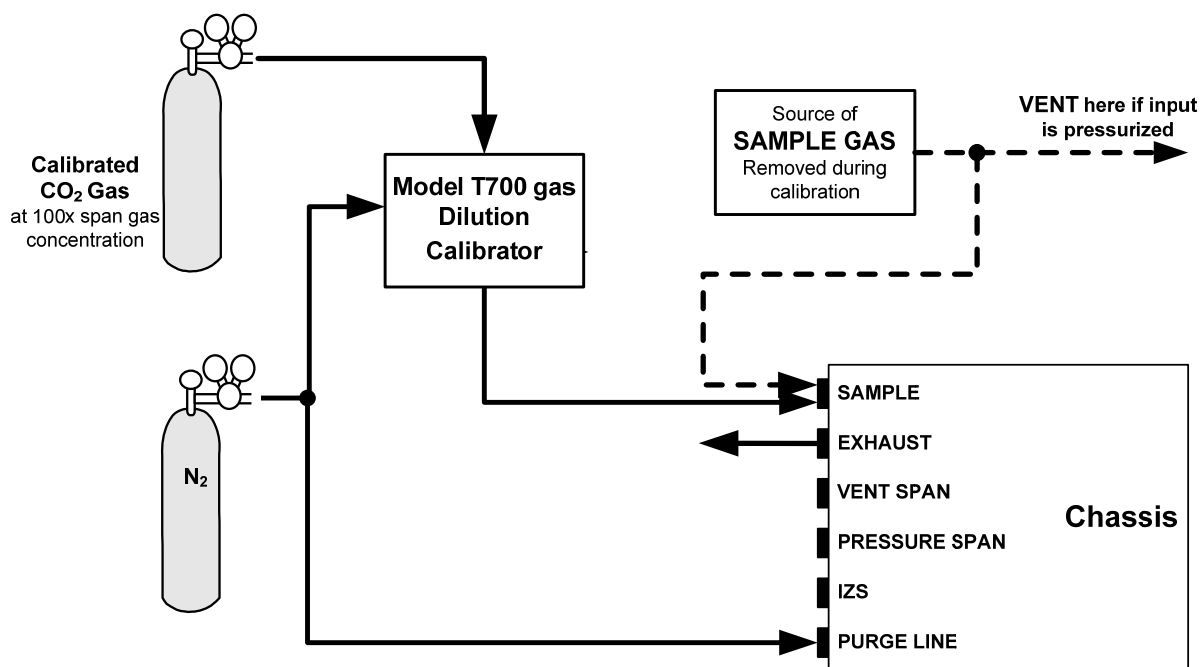

Figure 3-13: Pneumatic Connections–Basic Configuration–Using Gas Dilution Calibrator

1. Attach a sample inlet line to the sample inlet port. The SAMPLE input line should not be more than 2 meters long.

NOTE

Ideally, the pressure of the sample gas should be at ambient pressure (0 psig). Maximum pressure of sample gas should not exceed 1.5 in-Hg over ambient.

In applications where the sample gas is received from a pressurized manifold, a vent must be placed as shown to equalize the sample gas with ambient atmospheric pressure before it enters the analyzer. This vent line must be:

- At least 0.2m long
- No more than 2m long and vented outside the shelter or immediate area surrounding the instrument.

2. Attach sources of zero air and span gas (see Figures 3-3 through 3-8 inclusive).

- Span Gas is a gas specifically mixed to match the chemical composition of the type of gas being measured at near full scale of the desired measurement range.

In the case of CO₂ measurements made with the Teledyne Instruments Model T360 Analyzer it is recommended that you use a gas calibrated to have a CO₂ content equaling 80% of the range of compositions being measured.

EXAMPLE: If the application is to measure between 0 ppm and 500 ppm, an appropriate Span Gas would be 400 ppm. If the application is to measure between 0 ppm and 100 ppm, an appropriate Span Gas would be 80 ppm.

- Span Gas can be purchased in pressurized canisters or created using Dynamic Dilution Calibrator such as the Teledyne Instruments Model T700 and a source of dried air scrubbed of CO₂ such as a bottle of N₂.
- Zero Air is similar in chemical composition to the Earth's atmosphere but scrubbed of all components that might affect the analyzer's readings.

In the case of CO₂ measurements this means less than 0.1 ppm of CO₂ and Water Vapor (when dew point <-15°C). Zero Air can be purchased in pressurized canisters.

3. Attach an exhaust line to the exhaust outlet port.
 - The exhaust from the pump and vent lines should be vented to atmospheric pressure using maximum of 10 meters of 1/4" PTFE tubing.

**CAUTION**

Venting should be outside the shelter or immediate area surrounding the instrument.

4. Attach a source of dried air scrubbed of CO₂ to the purge inlet port.

NOTE

**The minimum gas pressure of the source of purge air should be 7.5 psig.
If the source of the purge air is shared by a Teledyne Instruments T700 (e.g., Figure 3-13) the minimum gas pressure should be 25 psig and should not exceed 35 psig.**

5. Once the appropriate pneumatic connections have been made, check all pneumatic fittings for leaks using a procedure similar to that defined in Section 6.3.3.

3.6.2. Connections with Ambient Zero/Ambient Span Valve

Figure 3-14 and Figure 3-15 show the pneumatic connections for the ambient zero and ambient span valve option (Option 50A).

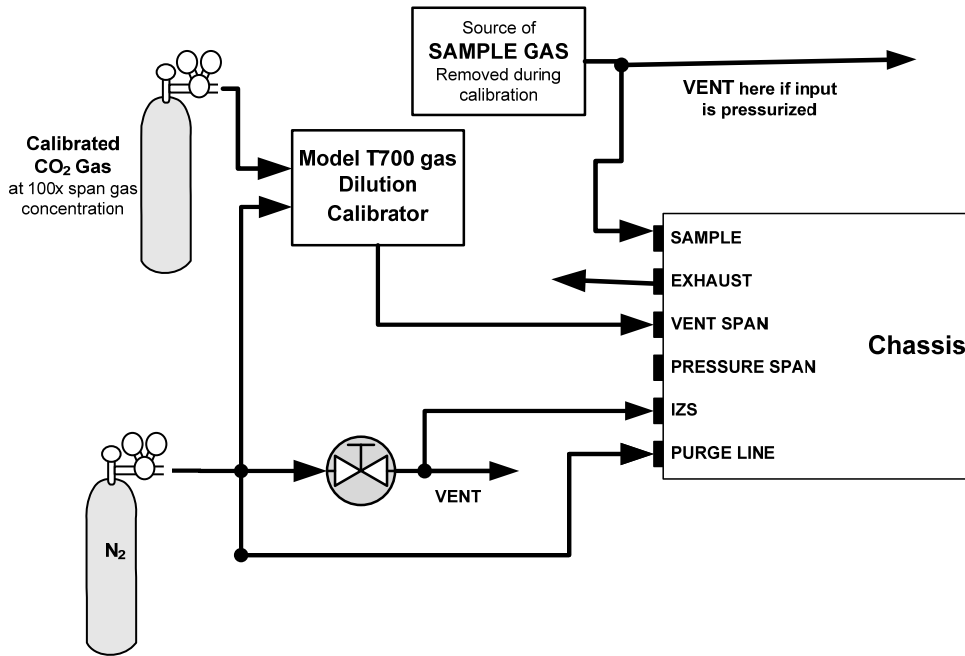

Figure 3-14: Pneumatic Connections with Ambient Zero/Ambient Span Valves (OPT 50A)

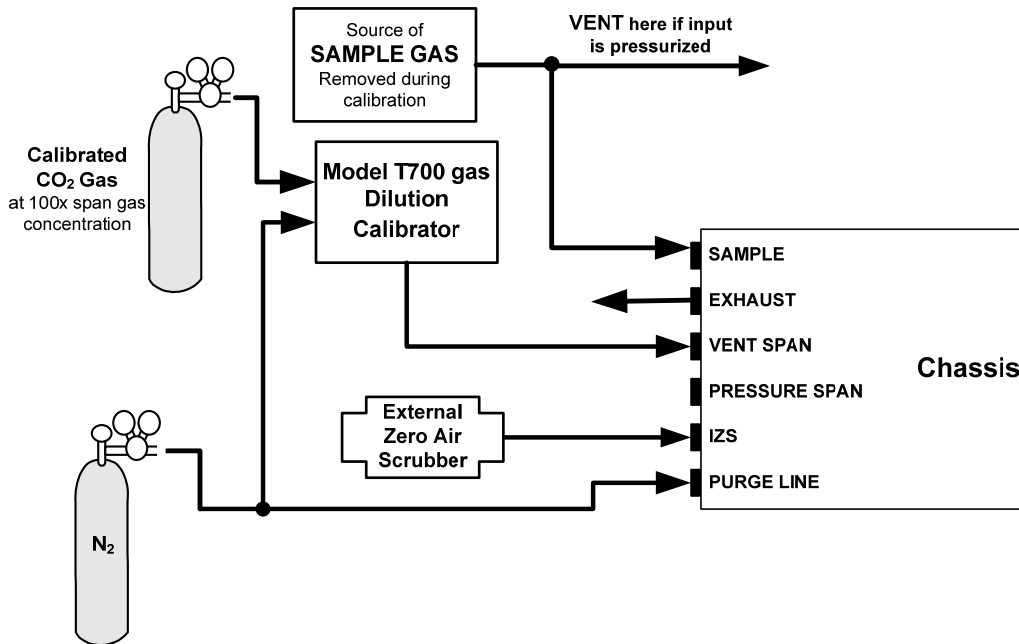

Figure 3-15: Pneumatic Connections with Ambient Zero/Ambient Span Valves (Opt 50A) and External Zero Air Scrubber

This valve option is intended for applications where zero air is supplied by a zero air generator like a bottle of N₂ and span gas are being supplied by Gas Dilution Calibrator like the Teledyne Instruments Model 700 or 702. Internal zero/span and sample/cal valves control the flow of gas through the instrument, but because the calibrator limits the flow of span gas no shutoff valve is required.

In order to ensure that span gas does not migrate backwards through the vent line and alter the concentration of the span gas, a gas line not less than 2 meters in length should be attached to the vent span outlet on the rear panel of the analyzer. To prevent the buildup of back pressure, this vent line should not be greater than 10 meters in length.

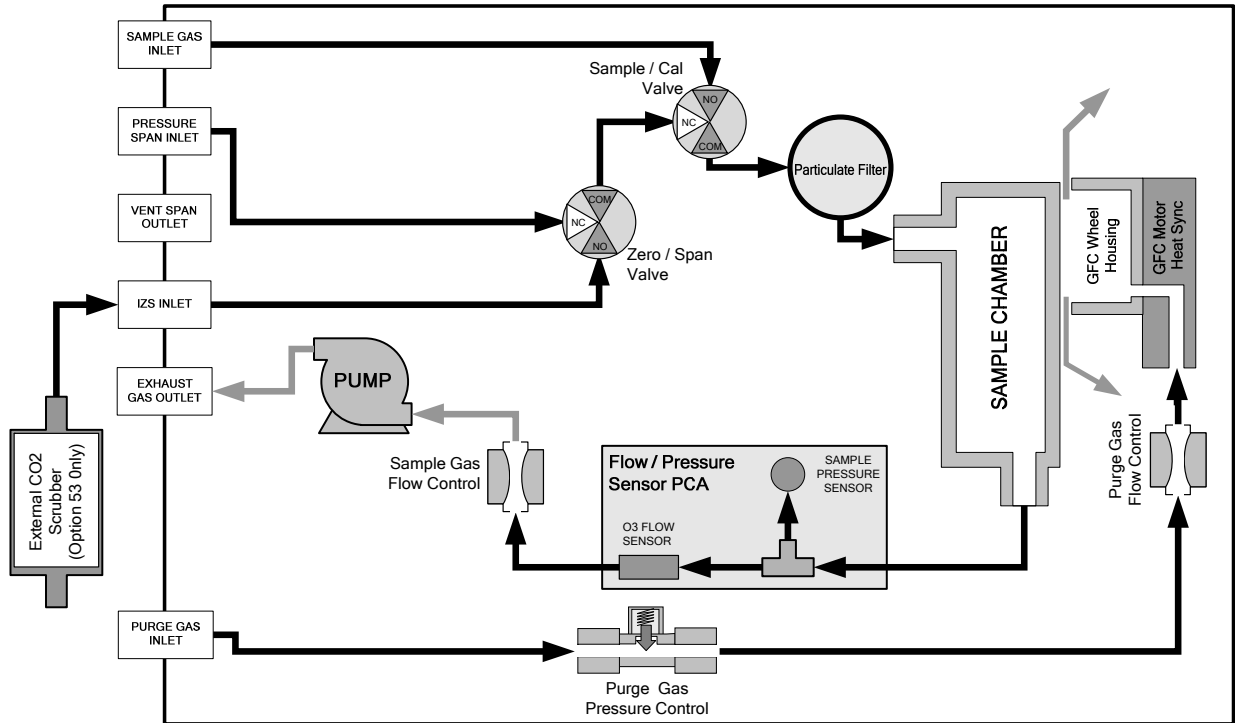

Figure 3-16: Internal Pneumatic Flow – Ambient Zero/Ambient Span

The following table describes the state of each valve during the analyzer’s various operational modes.

Table 3-9: Ambient Zero/Ambient Span Valve Operating States

Mode	Valve	Condition
SAMPLE (Normal State)	Sample/Cal	Open to SAMPLE inlet
	Zero/Span	Open to IZS inlet
ZERO CAL	Sample/Cal	Open to ZERO/SPAN valve
	Zero/Span	Open to IZS inlet
SPAN CAL	Sample/Cal	Open to ZERO/SPAN valve
	Zero/Span	Open to PRESSURE SPAN inlet

The minimum span gas flow rate required for this option is 800 cm³/min.

The state of the zero/span valves can also be controlled:

- Manually from the analyzer's front panel by using the Signal I/O controls located under the Diag Menu (Section 4.13),
- By activating the instrument's AutoCal feature (Section 5.6),
- Remotely by using the external digital control inputs (Section 4.15.1.2)
- Remotely through the RS-232/485 serial I/O ports (Section 4.15.2).

3.6.3. Connections with Ambient Zero/Pressurized Span Valve Option

Figure 3-17 and Figure 3-18 show the pneumatic connections for the ambient zero and pressurized span valve option (Option 50B).

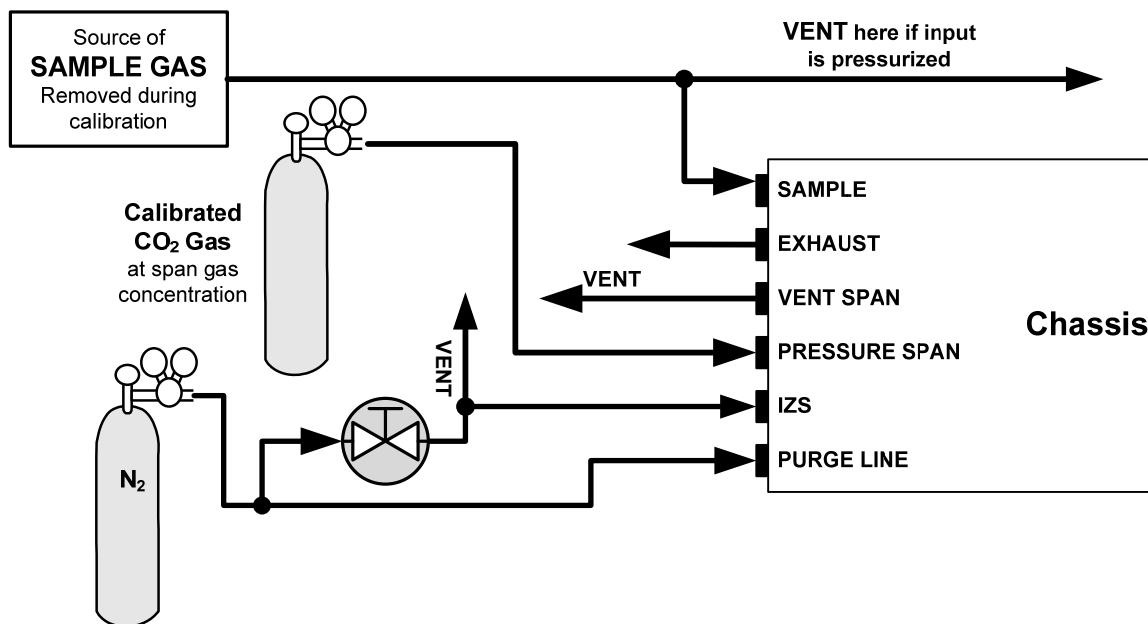

Figure 3-17: Pneumatic Connections with Ambient Zero/Pressurized Span Valves (OPT 50B)

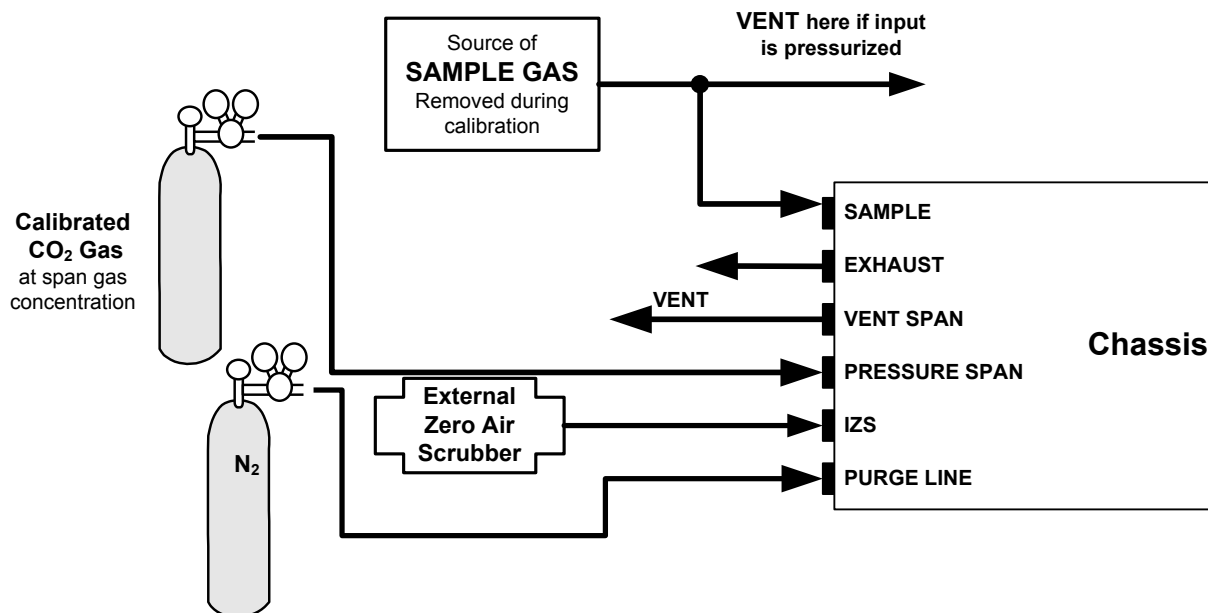

Figure 3-18: Pneumatic Connections with Ambient Zero/Pressurized Span Valves (Opt 50B) and External Zero Air Scrubber

This option requires that both zero air and span gas be supplied from external sources. It is specifically designed for applications where span gas will be supplied from a pressurized bottle of calibrated CO₂ gas. A critical flow control orifice, internal to the instrument ensures that the proper flow rate is maintained. An internal vent line, isolated by a shutoff valve ensures that the gas pressure of the span gas is reduced to ambient atmospheric pressure. Normally zero air would be supplied from zero air modules such as a Teledyne Instruments Model 701.

In order to ensure that span gas does not migrate backwards through the vent line and alter the concentration of the span gas, a gas line not less than 2 meters in length should be attached to the vent span outlet on the rear panel of the analyzer. To prevent the buildup of back pressure, this vent line should not be greater than 10 meters in length.

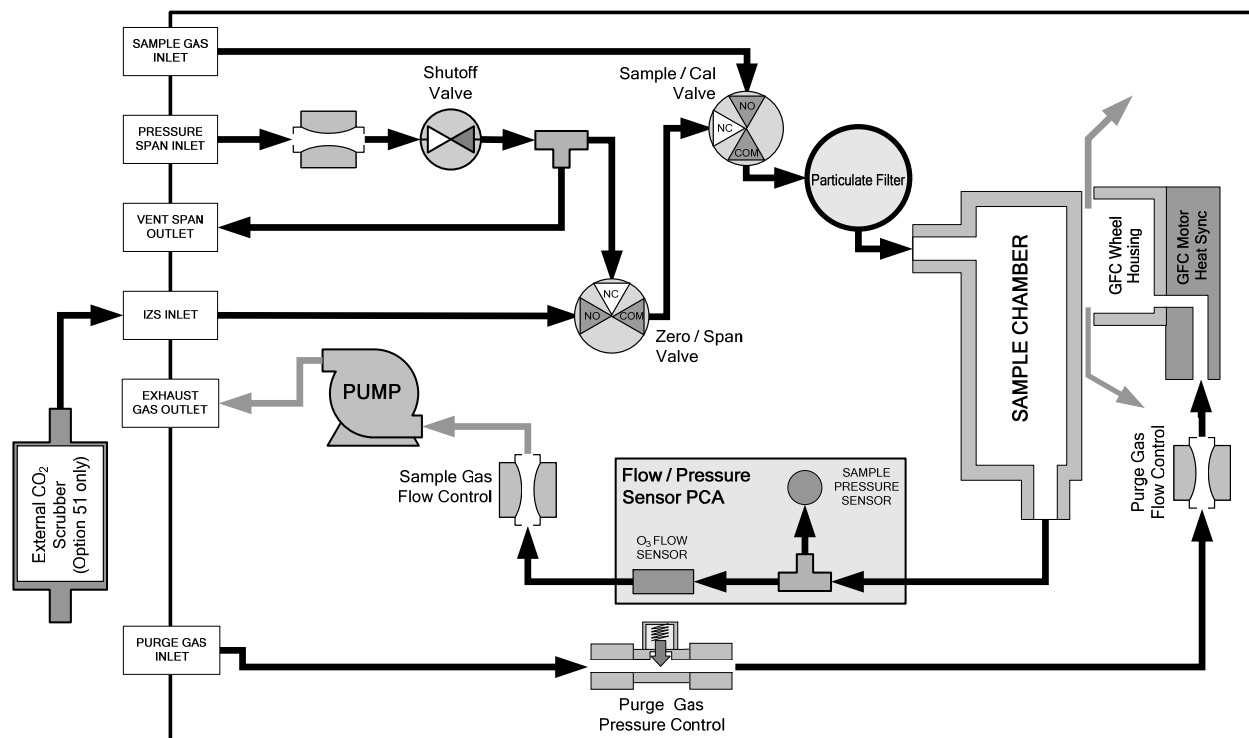

Figure 3-19: Internal Pneumatic Flow – Ambient Zero/Pressurized Span Valves

The following table describes the state of each valve during the analyzer's various operational modes.

Table 3-10: Ambient Zero/Pressurized Span Valve Operating States

MODE	VALVE	CONDITION
SAMPLE (Normal State)	Sample/Cal	Open to SAMPLE inlet
	Zero/Span	Open to IZS inlet
	Shutoff Valve	Closed
ZERO CAL	Sample/Cal	Open to ZERO/SPAN valve
	Zero/Span	Open to IZS inlet
	Shutoff Valve	Closed
SPAN CAL	Sample/Cal	Open to ZERO/SPAN valve
	Zero/Span	Open to SHUTOFF valve
	Shutoff Valve	Open to PRESSURE SPAN Inlet

The minimum span gas flow rate required for this option is 800 cm³/min.

The state of the zero/span valves can also be controlled:

- Manually from the analyzer's front panel by using the **SIGNAL I/O** controls located under the **DIAG** Menu (Section 4.13.2)
- By activating the instrument's AutoCal feature (Section 5.6)
- Remotely by using the external digital control inputs (Section 4.15.1.2)
- Remotely through the RS-232/485 serial I/O ports (see Appendix A-6 for the appropriate commands).

3.6.4. Pneumatic Connections in Multipoint Calibration Applications

Some applications may require multipoint calibration checks where span gas of several different concentrations is needed. We recommend using high-concentration, certified, calibration gas supplied to the analyzer through a Gas Dilution Calibrator such as a Teledyne Instruments Model T700. This type of calibrator precisely mixes Span Gas and Zero Air to produce any concentration level between 0 ppm and the concentration of the calibrated gas.

Figure 3-20 depicts the pneumatic set up in this sort of application of a Model T360 CO₂ Analyzer with ambient zero/ambient span valve option installed (a common configuration for this type of application).

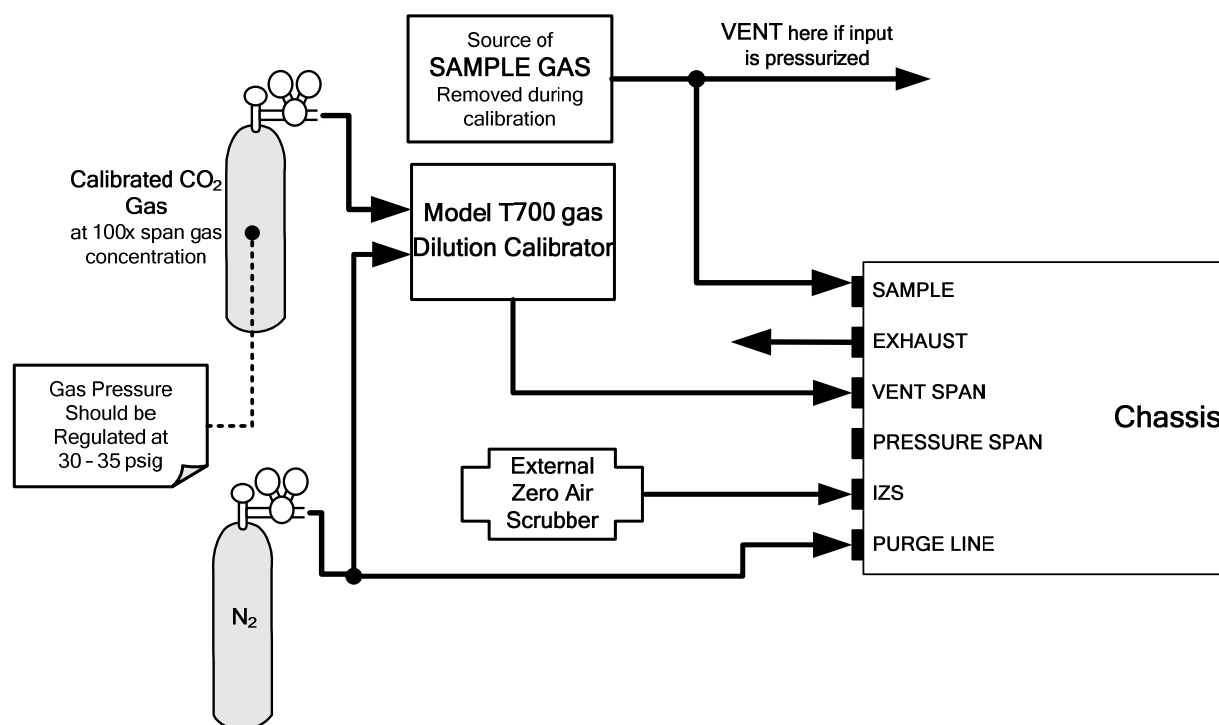

Figure 3-20: Example of Pneumatic Set up for Multipoint Calibration

3.6.5. Setting the Internal Purge Air Pressure

In order to maintain proper purge air flow through the GFC wheel housing, a manually adjustable pressure regulator is provided (see Figure 3-5). This regulator includes two output ports. One is used to supply purge air to the GFC wheel. The other may be used to attach a pressure gauge.

To adjust the internal purge air pressure of the T360:

1. Turn off the instrument.
2. Remove the source of zero air attached to the purge line inlet port at the back of the analyzer.
3. Remove the analyzer's top cover.

4. Remove the cap from the second, unused, output port on the pressure regulator.
5. Attach a pressure gauge capable of measuring in the 5-10 psig range with 0.5 psig resolution to the port.
6. Turn the instrument on.
7. Make sure the zero air supply to the analyzer's purge line inlet is supplying gas at a stable pressure above 7.5 psig.
8. Adjust the T360's pressure regulator until the attached gauge reads 7.5 psig.
9. Turn off the instrument.
10. Remove the source of zero air attached to the purge line inlet port at the back of the analyzer.
11. Remove the pressure gauge and reattach the end cap removed in step 4 above.
12. Replace the analyzer's top cover.

3.7. INITIAL OPERATION

If you are unfamiliar with the T360 principles of operation, we recommend that you read Section 7. For information on navigating the analyzer's software menus, see the menu trees described in Appendix A.

NOTE

The analyzer's cover must be installed to ensure that the temperatures of the GFC wheel and absorption cell assemblies are properly controlled.

3.7.1. Startup

After electrical and pneumatic connections are made, and initial functional check is required. Turn on the instrument. The pump, exhaust fan and PMT cooler fan should start immediately. The display will briefly show a logo splash screen at the start of initialization.

The analyzer should automatically switch to Sample Mode after completing the boot-up sequence and start monitoring CO₂ gas. However, there is an approximately one hour warm-up period before reliable gas measurements can be taken. During the warm-up period, the front panel display may show messages in the Parameters field.

3.7.2. Warm Up

During the warm-up period various portions of the instrument’s front panel may behave as indicated in Table 3-11.

Table 3-11: Front Panel Display During System Warm-Up

NAME	COLOR	BEHAVIOR	SIGNIFICANCE
Conc field	N/A	Displays current, compensated CO ₂ Concentration	This is normal operation, but deemed inaccurate during the warm-up period.
Mode field	N/A	Displays current mode, e.g., "SAMPLE"	Instrument is in Sample mode but is still in the process of warming up. (DAS holdoff period is active)
Param field	N/A	Displays menu items and messages.	Refer to Table 3-12 for a list and descriptions of warning messages.
STATUS LEDs			
Sample	Green	On	Unit is operating in sample mode; front panel display is being updated. Flashes On/Off when adaptive filter is active
Cal	Yellow	Off	The instrument’s calibration is not enabled.
Fault	Red	Blinking	The analyzer is warming up and hence out of specification for a fault-free reading. Various warning messages appear in the Param field.

3.7.3. Warning Messages

Because internal temperatures and other conditions may be outside be specified limits during the analyzer’s warm-up period, the software will suppress most warning conditions for 30 minutes after power up. If warning messages persist after the 30 minutes warm up period is over, investigate their cause using the troubleshooting guidelines in Section 8 of this manual.

To view and clear warning messages, press:

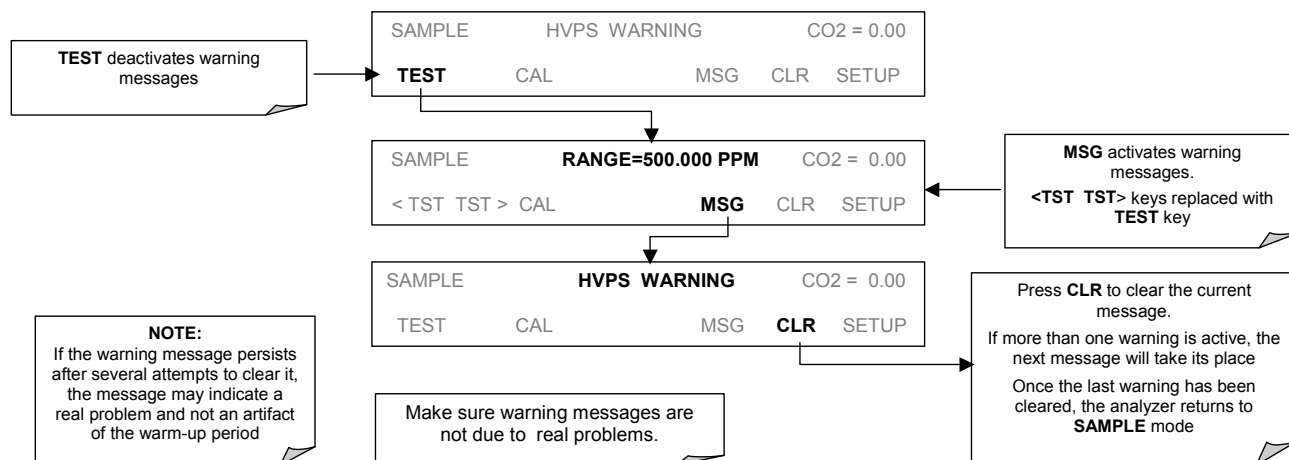

Table 3-12 lists brief descriptions of the warning messages that may occur during start up.

Table 3-12: Possible Warning Messages at Start-Up

MESSAGE	MEANING
ANALOG CAL WARNING	The instrument's A/D circuitry or one of its analog outputs is not calibrated.
BENCH TEMP WARNING	The optical bench Temperature is outside the specified limits.
BOX TEMP WARNING	Remote span calibration failed while the dynamic span feature was set to turned on.
CANNOT DYN SPAN	Remote zero calibration failed while the dynamic zero feature was set to turned on.
CANNOT DYN ZERO	Configuration was reset to factory defaults or was erased.
CONC ALRM1 WARNING	Concentration alarm 1 is enabled and the measured CO ₂ level is ≥ the set point.
CONC ALRM2 WARNING	Concentration alarm 2 is enabled and the measured CO ₂ level is ≥ the set point.
CONFIG INITIALIZED	Configuration storage was reset to factory configuration or erased.
DATA INITIALIZED	DAS data storage was erased.
O2 CELL TEMP WARN	O ₂ sensor cell temperature outside of warning limits.
PHOTO TEMP WARNING	The temperature of the IR photometer is outside the specified limits.
REAR BOARD NOT DET	The CPU is unable to communicate with the motherboard.
RELAY BOARD WARN	The firmware is unable to communicate with the relay board.
SAMPLE FLOW WARN	The flow rate of the sample gas is outside the specified limits.
SAMPLE PRESS WARN	Sample gas pressure outside of operational parameters.
SAMPLE TEMP WARN	The temperature of the sample gas is outside the specified limits.
SOURCE WARNING	The IR source may be faulty.
SYSTEM RESET	The computer was rebooted.
WHEEL TEMP WARNING	The Gas Filter Correlation wheel temperature is outside the specified limits.

3.7.4. Functional Checks

1. After the analyzer's components has warmed up for at least 30 minutes, verify that the software properly supports any hardware options that were installed.
2. Check to make sure that the analyzer is functioning within allowable operating parameters. Appendix C includes a list of test functions viewable from the analyzer's front panel as well as their expected values. These functions are also useful tools for diagnosing performance problems with your analyzer (Section 11.1.2). The enclosed Final Test and Validation Data sheet (part number 04307) lists these values before the instrument left the factory.

To view the current values of these parameters press the following button sequence on the analyzer's front panel. Remember until the unit has completed its warm up these parameters may not have stabilized.

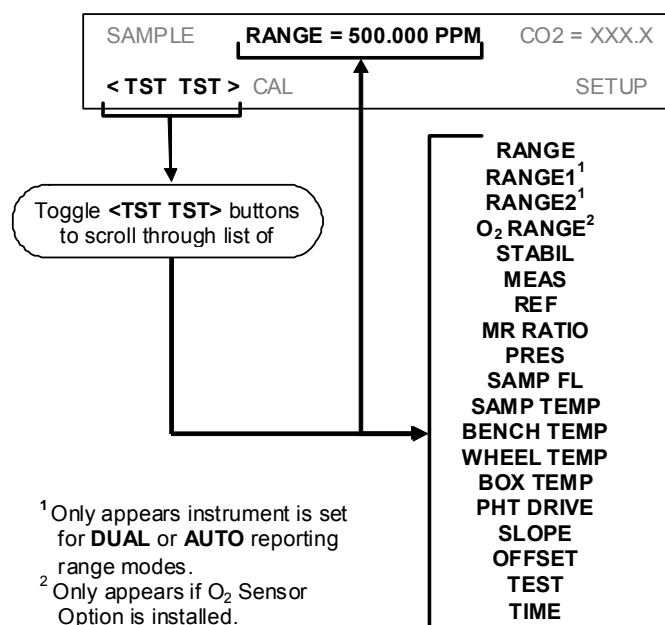

3. If your network is running a dynamic host configuration protocol (DHCP) software package, the Ethernet feature will automatically configure its interface with your LAN. (See Section 4.11.6.1). This configuration is useful for quickly getting an instrument up and running on a network. However, for permanent Ethernet connections, a static IP address should be used. (See Section 4.11.6.2).

3.8. INITIAL CALIBRATION PROCEDURE

The next task is to calibrate the analyzer.

To perform the following calibration you must have sources for zero air and span gas available for input into the sample port on the back of the analyzer. See Section 3.6 for instructions for connecting these gas sources.

While it is possible to perform this procedure with any range setting we recommend that you perform this initial checkout using the 500 ppm range.

The following procedure assumes that the instrument does not have any of the available Zero/Span Valve Options installed. See Section 5.4 for instructions for calibrating instruments with Z/S valve options.

1. Set the Analog Output Range:

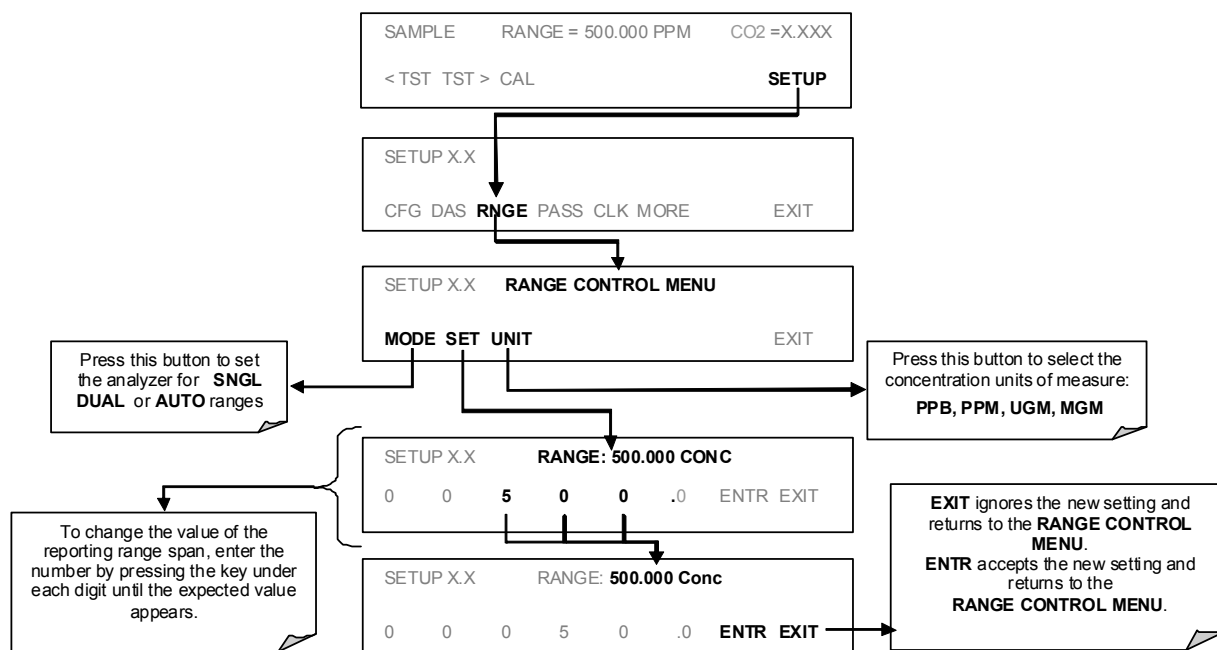

2. Set the expected CO₂ span gas concentration

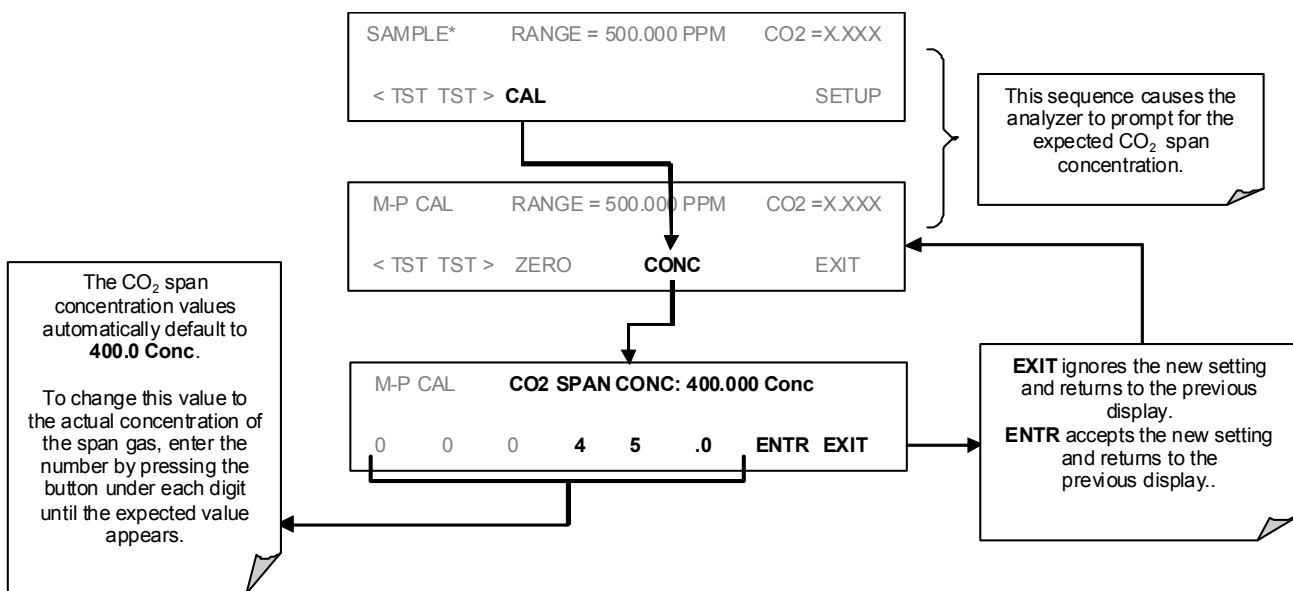

NOTE

For this Initial Calibration it is important to independently verify the precise CO₂ Concentration Value of the SPAN gas.

If the source of the Span Gas is from a Calibrated Bottle, use the exact concentration value printed on the bottle.

3. Perform the Zero/Span Calibration Procedure

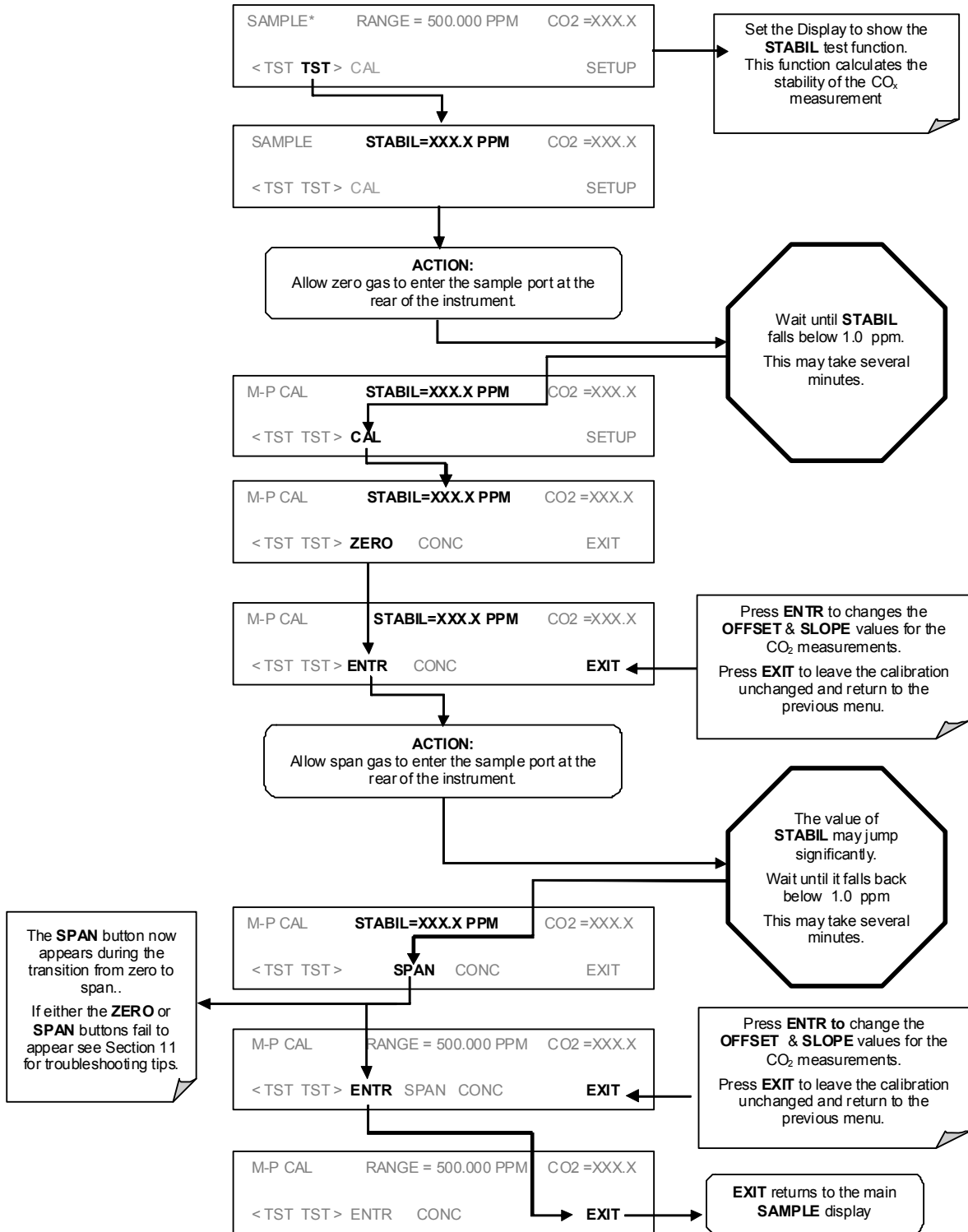

3.8.1. Initial O₂ Sensor Calibration Procedure

If your instrument includes the O₂ sensor option, that should be calibrated as well.

3.8.1.1. O₂ SENSOR CALIBRATION SETUP

The pneumatic connections for calibrating are as follows:

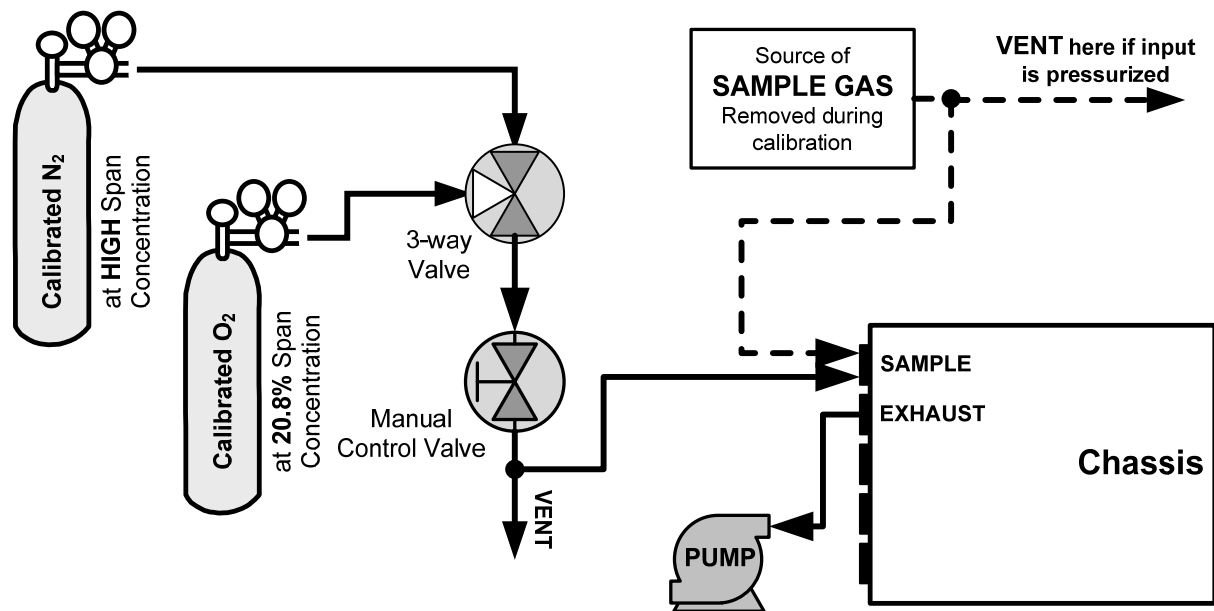

Figure 3-21: O₂ Sensor Calibration Set Up

O₂ SENSOR ZERO GAS: Teledyne Instruments' recommends using pure N₂ when calibration the zero point of your O₂ sensor option.

O₂ SENSOR SPAN GAS: Teledyne Instruments' recommends using 21% O₂ in N₂ when calibration the span point of your O₂ sensor option.

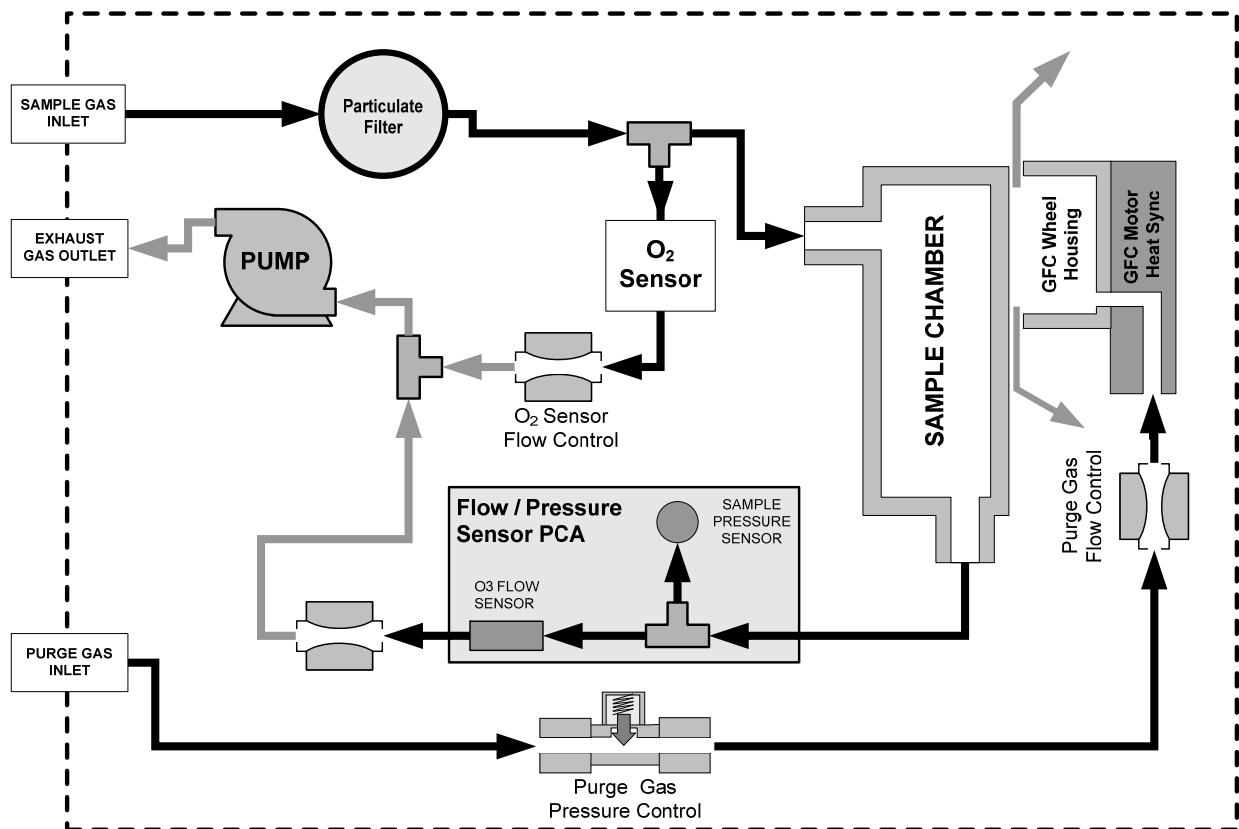

Figure 3-22: Internal Pneumatics with O₂ Sensor Option 65

3.8.1.2. O₂ CALIBRATION METHOD

STEP 1 – SET O₂ SPAN GAS CONCENTRATION :

Set the expected O₂ span gas concentration.

This should be equal to the percent concentration of the O₂ span gas of the selected reporting range (default factory setting = 20.8%; the approximate O₂ content of ambient air).

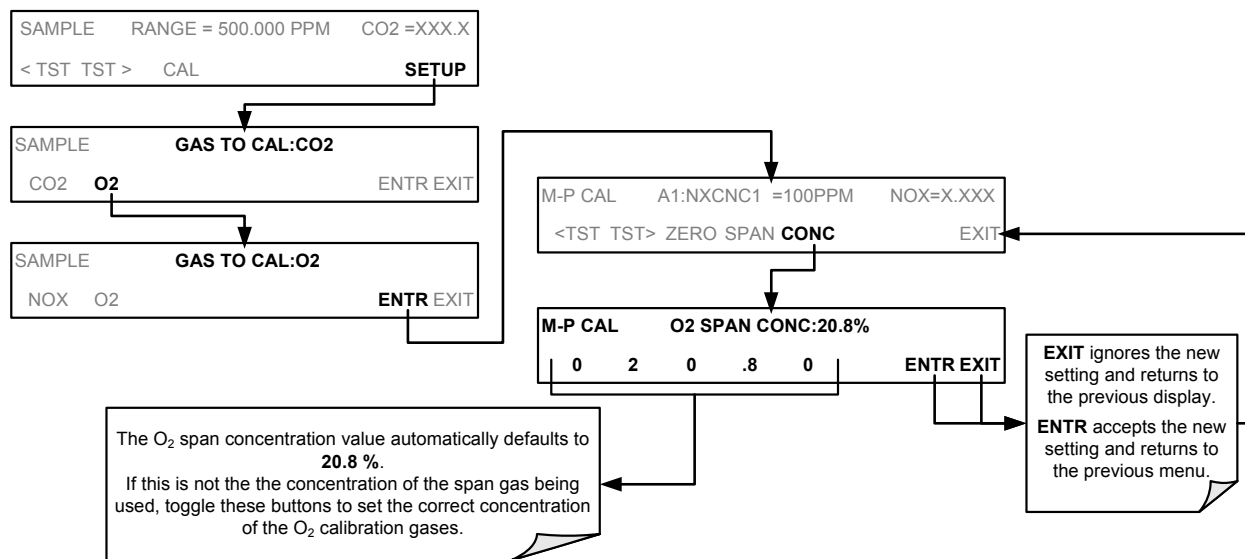

STEP 2 – ACTIVATE O₂ SENSOR STABILITY FUNCTION

To change the stability test function from NO_x concentration to the O₂ sensor output, press:

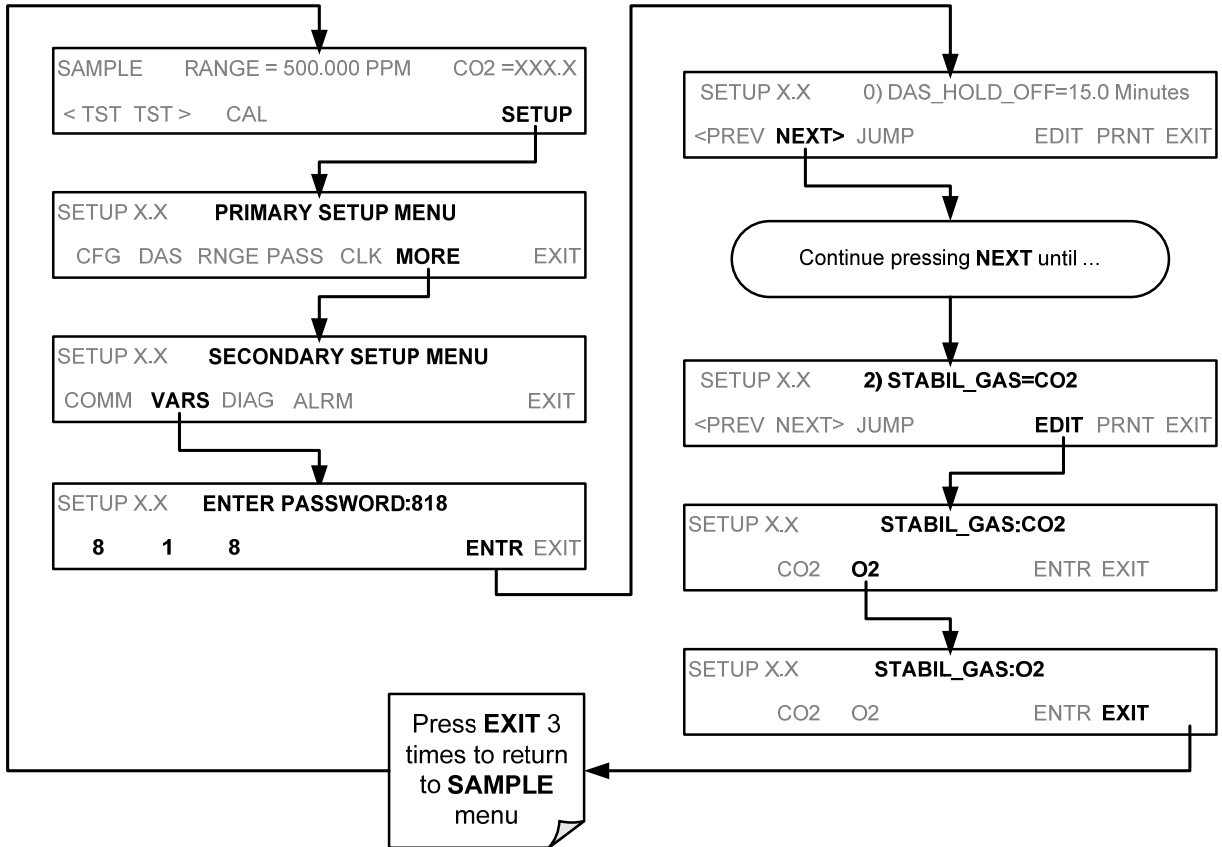

NOTE

Use the same procedure to reset the STB test function to CO₂ when the O₂ calibration procedure is complete.

STEP 4 – O₂ Zero/Span Calibration perform by pressing:

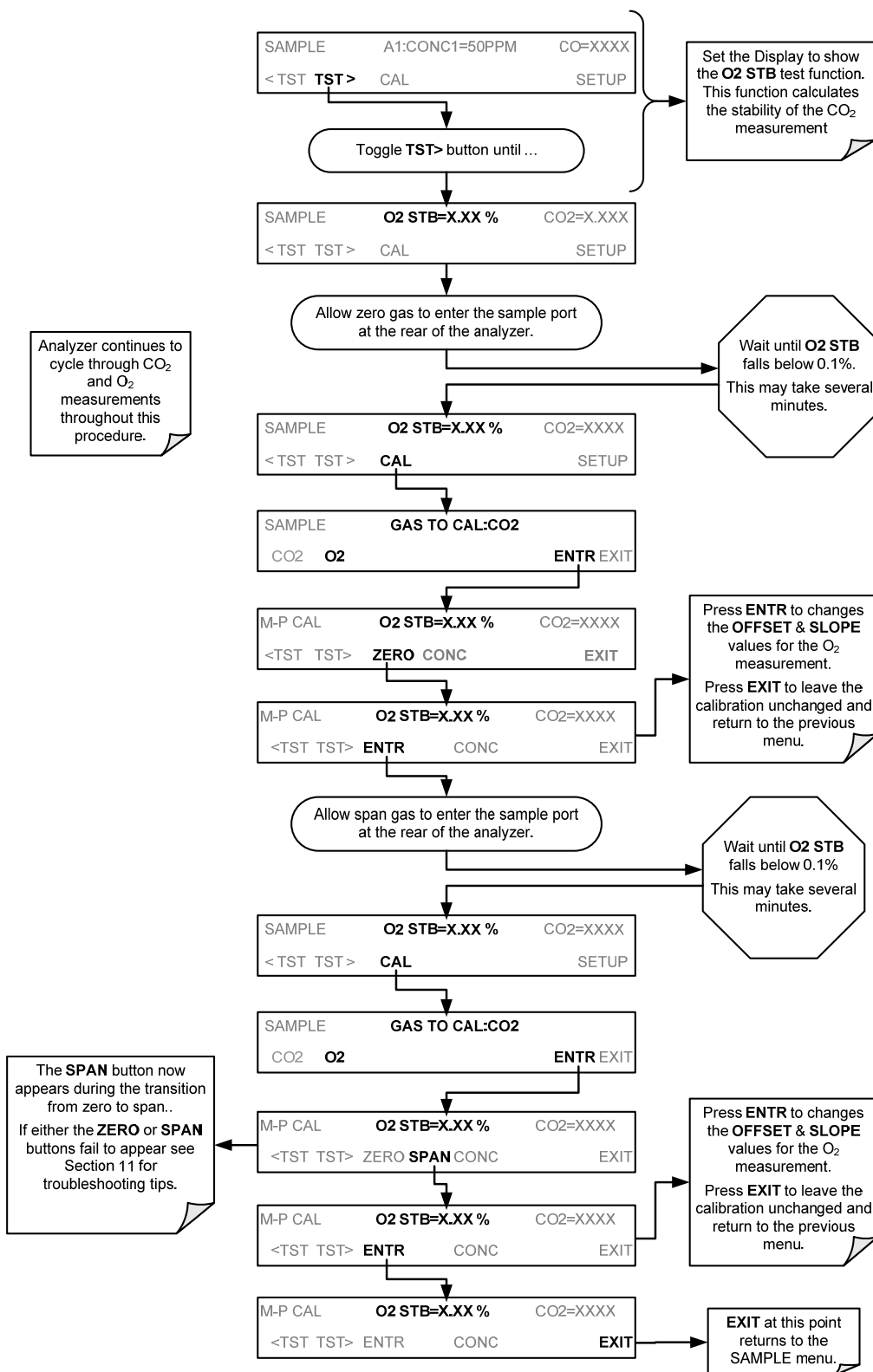

The analyzer is now ready for operation.

NOTE

Once you have completed the preceding set-up procedures, please fill out the Quality Questionnaire that was shipped with your unit and return it to Teledyne Instruments.

This information is vital to our efforts in continuously improving our service and our products.

THANK YOU.

4. OPERATING INSTRUCTIONS

To assist in navigating the analyzer's software, a series of menu trees can be found in Appendix A-1 of this manual.

NOTES

The flow charts appearing in this contain typical representations of the analyzer's display during the various operations being described. These representations may differ slightly from the actual display of your instrument.

The ENTR button may disappear if you select a setting that is invalid or out of the allowable range for that parameter, such as trying to set the 24-hour clock to 25:00:00. Once you adjust the setting to an allowable value, **the ENTR button will re-appear**.

4.1. OVERVIEW OF OPERATING MODES

The T360 software has a variety of operating modes. Most commonly, the analyzer will be operating in **SAMPLE** mode. In this mode, a continuous read-out of the CO₂ concentration is displayed on the front panel and output as an analog voltage from rear panel terminals, calibrations can be performed, and **TEST** functions and **WARNING** messages can be examined.

The second most important operating mode is **SETUP** mode. This mode is used for performing certain configuration operations, such as for the DAS system, the reporting ranges, or the serial (RS-232/RS-485/Ethernet) communication channels. The **SET UP** mode is also used for performing various diagnostic tests during troubleshooting.

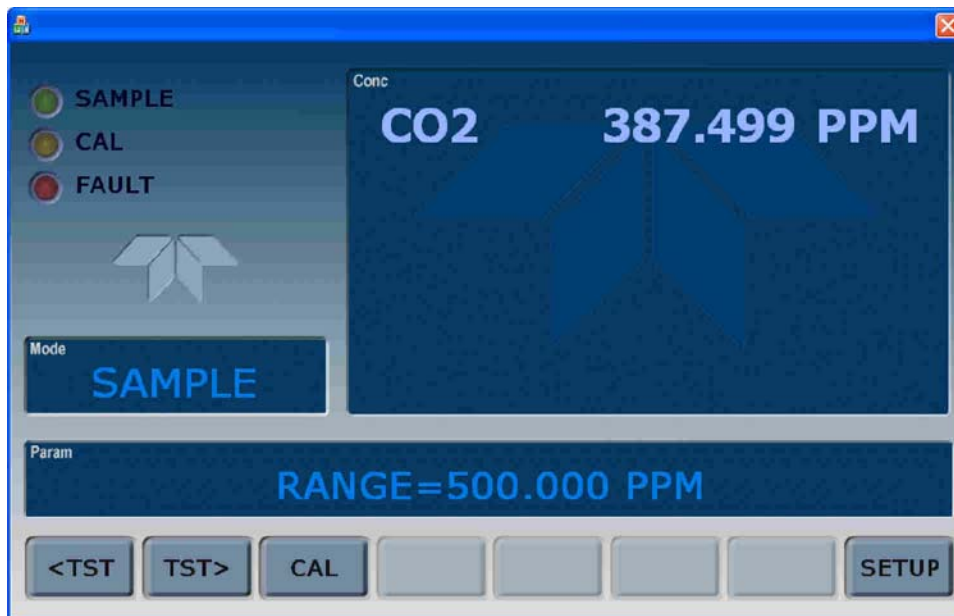

Figure 4-1: Front Panel Display

The Mode field of the front panel display indicates to the user which operating mode the unit is currently running.

Besides **SAMPLE** and **SETUP**, other modes the analyzer can be operated in are:

Table 4-1: Analyzer Operating Modes

MODE	MEANING
DIAG	One of the analyzer's diagnostic modes is being utilized (See Section 4.13).
M-P CAL	This is the basic, multi-point calibration mode of the instrument and is activated by pressing the CAL button.
SAMPLE	Sampling normally, flashing indicates adaptive filter is on.
SAMPLE A	Indicates that unit is in SAMPLE Mode and AUTOCAL feature is activated.
SETUP	SETUP mode is being used to configure the analyzer (CO ₂ sampling will continue during this process).
SPAN CAL A	Unit is performing span cal procedure initiated automatically by the analyzer's AUTOCAL feature.
SPAN CAL M	Unit is performing span cal procedure initiated manually by the user.
SPAN CAL R	Unit is performing span cal procedure initiated remotely via the RS-232, RS-4485 or digital i/o control inputs.
ZERO CAL A	Unit is performing zero cal procedure initiated automatically by the analyzer's AUTOCAL feature.
ZERO CAL M	Unit is performing zero cal procedure initiated manually by the user.
ZERO CAL R	Unit is performing zero cal procedure initiated remotely via the RS-232, RS-4485 or digital I/O control inputs.

Finally, the various **CAL** modes allow calibration of the analyzer. Because of its importance, this mode is described separately in Section 5.

4.2. SAMPLE MODE

This is the analyzer's standard operating mode. In this mode the instrument is analyzing the gas in the sample chamber, calculating CO₂ concentration and reporting this information to the user via the front panel display, the analog outputs and, if set up properly, the RS-232/485/Ethernet ports.

NOTE

A value of "XXXX" displayed in the CO₂ Concentration field means that the M/R ratio is invalid because CO₂ REF is either too high (> 4950 mVDC) or too low (< 1250 VDC).

4.2.1. Test Functions

Test functions are shown on the front panel display while the analyzer is in **SAMPLE** mode. They provide information about the present operating status of the instrument and can be used troubleshooting and can be recorded in one of the DAS channels (Section 4.7) for data analysis. To view, press <TST or TST>.

Table 4-2: Test Functions Defined

PARAMETER	DISPLAY	UNITS	MEANING
Range	RANGE RANGE1¹ RANGE2¹	PPB, PPM, UGM, MGM	The full scale limit at which the reporting range of the analyzer is currently set. THIS IS NOT the Physical Range of the instrument. See Section 4.8 for more information.
O ₂ Range	O2 RANGE	%	The range setting for the O ₂ Sensor
Stability	STABIL	PPB, PPM UGM, MGM	Standard deviation of CO ₂ concentration readings. Data points are recorded every ten seconds using the last 25 data points.
CO ₂ Measure	MEAS	MV	The demodulated, peak IR detector output during the measure portion of the GFC Wheel cycle.
CO ₂ Reference	REF	MV	The demodulated, peak IR detector output during the reference portion of the GFC wheel cycle.
Measurement / Reference Ratio	MR Ratio	-	The result of CO2 MEAS divided by CO2 REF . This ratio is the primary value used to compute CO ₂ concentration. The value displayed is not linearized.
Sample Pressure	PRES	In-Hg-A	The absolute pressure of the Sample gas as measured by a pressure sensor located inside the sample chamber.
Sample Flow	SAMPLE FL	cc/min	Sample mass flow rate. This is computed from the differential between the pressures measured up-stream and down-stream of the sample critical flow orifice pressures.
Sample Temperature	SAMP TEMP	°C	The temperature of the gas inside the sample chamber.
Bench Temperature	BENCH TEMP	°C	Optical bench temperature.
Wheel Temperature	WHEEL TEMP	°C	Filter wheel temperature.
Box Temperature	BOX TEMP	°C	The temperature inside the analyzer chassis.
O ₂ Cell Temperature ²	O2 CELL TEMP²	°C	O ₂ sensor cell temperature.
Photo-detector Temp. Control Voltage	PHT DRIVE	mV	The drive voltage being supplied to the thermoelectric coolers of the IR photo-detector by the sync/demod Board.
Slope	SLOPE	-	The sensitivity of the instrument as calculated during the last calibration activity. The SLOPE parameter is used to set the span calibration point of the analyzer.
Offset	OFFSET	-	The overall offset of the instrument as calculated during the last calibration activity. The OFFSET parameter is used to set the zero point of the analyzer response.
O ₂ Sensor Slope ²	O2 SLOPE	-	O ₂ slope, computed during zero/span calibration.
O ₂ Sensor Offset ²	O2 OFFSET	-	O ₂ offset, computed during zero/span calibration.
Test channel output signal	TEST	mV, mA	Displays the signal level of the TEST analog output channel. Only appears when the TEST channel has been activated.
Current Time	TIME	-	The current time. This is used to create a time stamp on DAS readings, and by the AUTOCAL feature to trigger calibration events.

¹ Only appears when the instrument's reporting range mode is set for **DUAL** or **AUTO**

² Only appears when the optional O₂ sensor is installed.

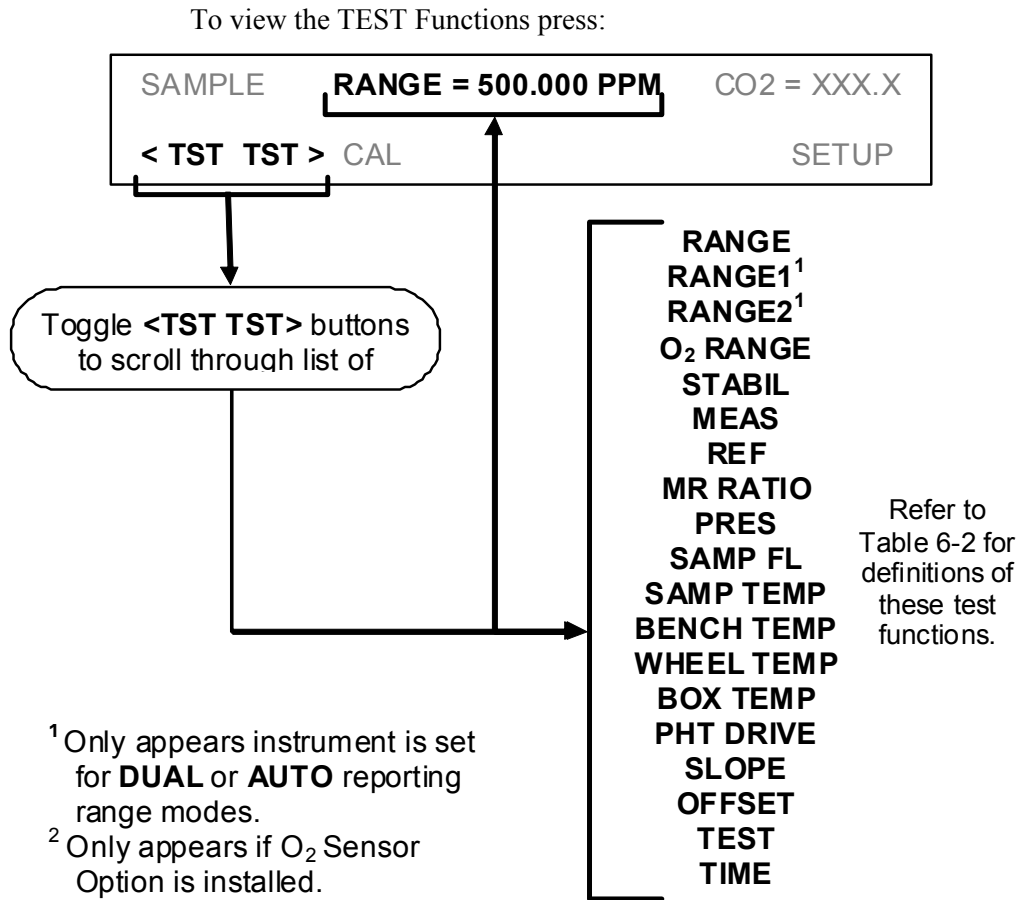

Figure 4-2: Viewing TEST Functions

NOTE

A value of “XXXX” displayed for any of the TEST functions indicates an out-of-range reading or the analyzer’s inability to calculate it.

All pressure measurements are represented in terms of absolute pressure. Absolute, atmospheric pressure is 29.92 in-Hg-A at sea level. It decreases about 1 in-Hg per 300 m gain in altitude. A variety of factors such as air conditioning and passing storms can cause changes in the absolute atmospheric pressure.

4.2.2. Warning Messages

The most common instrument failures will be reported as a warning on the analyzer’s front panel and through the COM ports. Section 8.1.1 explains how to use these messages to troubleshoot problems. Section 3.7.3 shows how to view and clear warning messages.

Table 4-3 lists warning messages for the current version of software.

Table 4-3: List of Warning Messages

MESSAGE	MEANING
ANALOG CAL WARNING	The instrument's A/D circuitry or one of its analog outputs is not calibrated.
BENCH TEMP WARNING	The Temperature of the optical bench is outside the specified limits.
BOX TEMP WARNING	Remote span calibration failed while the dynamic span feature was set to turned on
CANNOT DYN SPAN	Remote zero calibration failed while the dynamic zero feature was set to turned on
CANNOT DYN ZERO	Configuration was reset to factory defaults or was erased.
CONC ALRM1 WARNING	Concentration alarm 1 is enabled and the measured CO ₂ level is ≥ the set point.
CONC ALRM2 WARNING	Concentration alarm 2 is enabled and the measured CO ₂ level is ≥ the set point.
CONFIG INITIALIZED	Configuration storage was reset to factory configuration or erased.
DATA INITIALIZED	DAS data storage was erased.
O2 CELL TEMP WARN	O ₂ sensor cell temperature outside of warning limits.
PHOTO TEMP WARNING	The temperature of the IR photometer is outside the specified limits.
REAR BOARD NOT DET	The CPU is unable to communicate with the motherboard.
RELAY BOARD WARN	The firmware is unable to communicate with the relay board.
SAMPLE FLOW WARN	The flow rate of the sample gas is outside the specified limits.
SAMPLE PRESS WARN	Sample gas pressure outside of operational parameters.
SAMPLE TEMP WARN	The temperature of the sample gas is outside the specified limits.
SOURCE WARNING	The IR source may be faulty.
SYSTEM RESET	The computer was rebooted.
WHEEL TEMP WARNING	The Gas Filter Correlation wheel temperature is outside the specified limits.

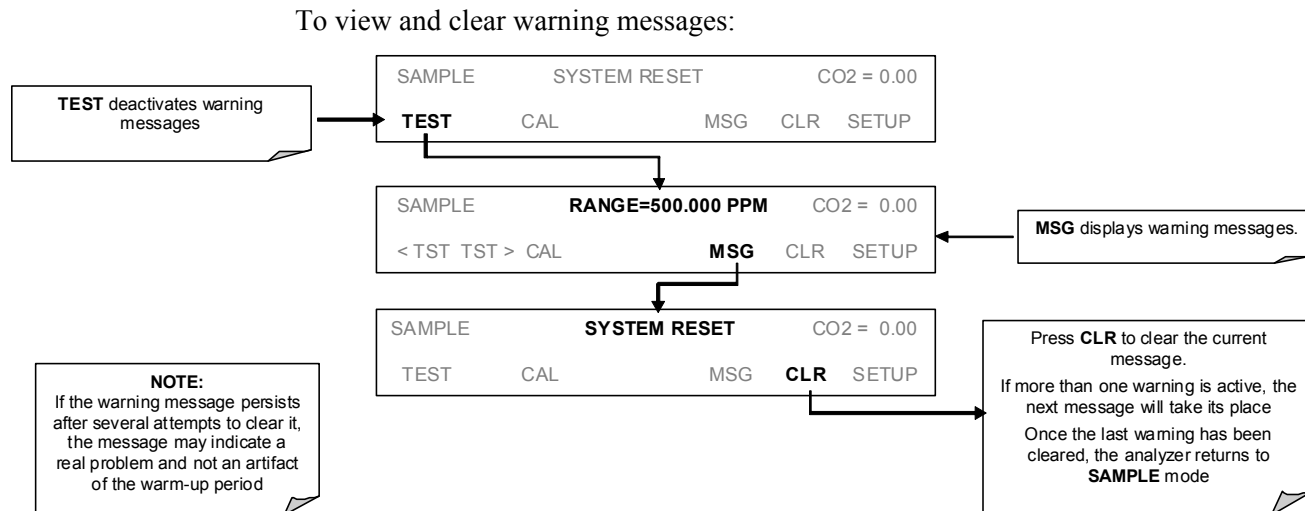

Figure 4-3: Viewing and Clearing T360 WARNING Messages

4.3. CALIBRATION MODE

Pressing the **CAL** button switches the T360 into multi-point calibration mode. In this mode, the user can calibrate the instrument or check the instruments calibration with the use of calibrated zero or span gases.

If the instrument includes either the zero/span valve option or IZS option, the display will also include **CALZ** and **CALS** buttons. Pressing either of these buttons also puts the instrument into multipoint calibration mode.

- **CALZ** is used to initiate a calibration of the zero point.
- **CALS** is used to calibrate the span point of the analyzer. It is recommended that this span calibration is performed at 90% of full scale of the analyzer's currently selected reporting range.

Because of their critical importance and complexity, calibration operations are described in detail in Section 5 of this manual. For more information concerning the valve options, see Section 3.6.

4.4. SETUP MODE

The **SETUP** mode contains a variety of choices that are used to configure the analyzer's hardware and software features, perform diagnostic procedures, gather information on the instruments performance and configure or access data from the internal data acquisition system (DAS). For a visual representation of the software menu trees, refer to Appendix A. The areas access under the Setup mode are presented in Table 4-4 and Table 4-5.

Table 4-4: Primary Setup Mode Features and Functions

MODE OR FEATURE	TOUCHSCREEN BUTTON	DESCRIPTION
Analyzer Configuration	CFG	Lists key hardware and software configuration information
Auto Cal Feature	ACAL	Used to set up and operate the AutoCal feature. Only appears if the analyzer has one of the internal valve options installed
Internal Data Acquisition (DAS)	DAS	Used to set up the DAS system and view recorded data
Analog Output Reporting Range Configuration	RNGE	Used to configure the output signals generated by the instruments Analog outputs.
Calibration Password Security	PASS	Turns the calibration password feature ON/OFF
Internal Clock Configuration	CLK	Used to Set or adjust the instrument's internal clock
Advanced SETUP Features	MORE	This button accesses the instruments secondary setup menu

Table 4-5: Secondary Setup Mode Features and Functions

MODE OR FEATURE	TOUCHSCREEN BUTTON	DESCRIPTION
External Communication Channel Configuration	COMM	Used to set up and operate the analyzer's various external I/O channels including RS-232; RS-485, modem communication and/or Ethernet access.
System Status Variables	VARS	Used to view various variables related to the instruments current operational status
System Diagnostic Features	DIAG	Used to access a variety of functions that are used to configure, test or diagnose problems with a variety of the analyzer's basic systems
CO ₂ Concentration Alarms	ALRM	Used to activate the analyzer's two gas concentration status alarms and set the alarm limits

NOTE

**Press ENTR to accept/apply changes made to a variable.
Press EXIT to ignore the change(s). (There will be an audible alert that the change has been lost).**

4.5. SETUP → CFG: VIEWING THE ANALYZER'S CONFIGURATION INFORMATION

Pressing the CFG button displays the instrument configuration information. This display lists the analyzer model, serial number, firmware revision, software library revision, CPU type and other information. Use this information to identify the software and hardware when contacting Technical Support. Special instrument or software features or installed options may also be listed here.

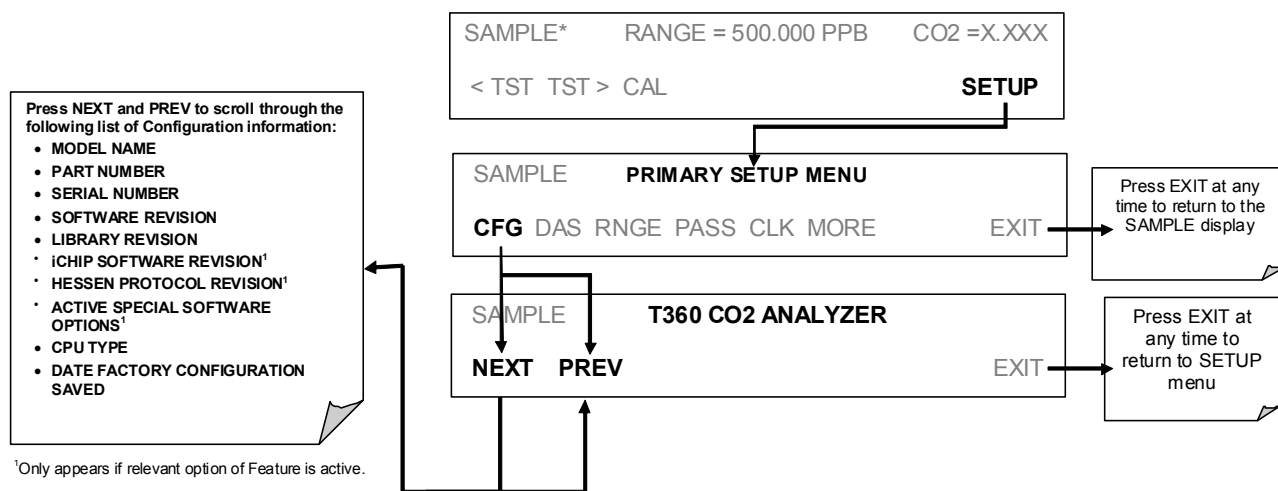

4.6. SETUP → ACAL: AUTOMATIC CALIBRATION

Instruments with one of the internal valve options installed can be set to automatically run calibration procedures and calibration checks. These automatic procedures are programmed using the submenus and functions found under the ACAL menu.

A menu tree showing the ACAL menu's entire structure can be found in Appendix A-1 of this manual.

Instructions for using the ACAL feature are located in Section 5.6 of this manual.

4.7. SETUP → DAS: USING THE DATA ACQUISITION SYSTEM (DAS)

The T360 analyzer contains a flexible and powerful, internal data acquisition system (DAS) that enables the analyzer to store concentration and calibration data as well as a host of diagnostic parameters. The DAS of the T360 can store several months worth of measurements, depending on how it is configured. The data are stored in non-volatile memory and are retained even when the instrument is powered off. Data are stored in plain text format for easy retrieval and use in common data analysis programs (such as spreadsheet-type programs).

The DAS is designed to be flexible, users have full control over the type, length and reporting time of the data. The DAS permits users to access stored data through the instrument's front panel or its communication ports. Using APICOM, data can even be retrieved automatically to a remote computer for further processing.

The principal use of the DAS is logging data for trend analysis and predictive diagnostics, which can assist in identifying possible problems before they affect the functionality of the analyzer. The secondary use is for data analysis, documentation and archival in electronic format.

To support the DAS functionality, Teledyne API offers APICOM, a program that provides a visual interface for remote or local setup, configuration and data retrieval of the DAS (Section 4.15.2.8). The APICOM manual, which is included with the program, contains a more detailed description of the DAS structure and configuration.

The T360 is configured with a basic DAS configuration, which is enabled by default. New data channels are also enabled by default but each channel may be turned off for later or occasional use. Note that DAS operation is suspended while its configuration is edited through the front panel. To prevent such data loss, it is recommended to use the APICOM graphical user interface for DAS changes.

The green SAMPLE LED on the instrument front panel, which indicates the analyzer status, also indicates certain aspects of the DAS status:

Table 4-6: Secondary Setup Mode Features and Functions

LED STATE	DAS Status
OFF	System is in calibration mode. Data logging can be enabled or disabled for this mode. Calibration data are typically stored at the end of calibration periods, concentration data are typically not sampled, diagnostic data should be collected.
BLINKING	Instrument is in hold-off mode, a short period after the system exits calibrations. DAS channels can be enabled or disabled for this period. Concentration data are typically disabled whereas diagnostic should be collected.
ON	Sampling normally.

The DAS can be disabled only by disabling or deleting its individual data channels.

4.7.1. DAS Structure

The DAS is designed around the feature of a “record”. A record is a single data point of one parameter, stored in one (or more) data channels and generated by one of several triggering event. The entire DAS configuration is stored in a script, which can be edited from the front panel or downloaded, edited and uploaded to the instrument in form of a string of plain-text lines through the communication ports.

DAS data are defined by the PARAMETER type and are stored through different triggering EVENTS in data CHANNELS, which relate triggering events to data parameters and define certain operational functions related to the recording and reporting of the data.

4.7.1.1. DAS CHANNELS

The key to the flexibility of the DAS is its ability to store a large number of combinations of triggering events and data parameters in the form of data channels. Users may create up to 20 data channels; each channel can contain one or more parameters. For each channel one triggering event is selected and up to 50 data parameters, which can be the same or different between channels. Each data channel has several properties that define the structure of the channel and allow the user to make operational decisions regarding the channel (Table 4-7).

Table 4-7: DAS Data Channel Properties

PROPERTY	DESCRIPTION	DEFAULT	SETTING RANGE
NAME	The name of the data channel.	“NONE”	Up to 6 letters and digits (more with APICOM, but only the first six are displayed on the front panel).
TRIGGERING EVENT	The event that triggers the data channel to measure and store its data parameters. See APPENDIX A-5 for a list of available triggering events.	ATIMER	See Appendix A-5 For a complete list.
NUMBER & PARAMETER LIST	A user-configurable list of data types to be recorded in any given channel. See APPENDIX A-5 for a list of available parameters	1 – DETMES	See Appendix A-5 For a complete list.
STARTING DATE	The starting date when a channel starts collecting data	01-JAN-03	Any actual date in the past or future.
SAMPLE PERIOD	The amount of time between each data point that is averaged into one mean reported every REPORT PERIOD.	000:01:00	000:00:01 to 366:23:59 (Days:Hours:Minutes)
REPORT PERIOD	The amount of time between each channel data point.	000:01:00	000:00:01 to 366:23:59 (Days:Hours:Minutes)
NUMBER OF RECORDS	The number of reports that will be stored in the data file. Once the specified limit has been exceeded, the oldest data are over-written to make space for new data.	100	1 to 1 million, limited by available storage space.
RS-232 REPORT	Enables the analyzer to automatically report channel values to the RS-232 ports.	OFF	OFF or ON
CHANNEL ENABLED	Enables or disables the channel. Provides a convenient means to temporarily disable a data channel.	ON	OFF or ON

PROPERTY	DESCRIPTION	DEFAULT	SETTING RANGE
CAL HOLD OFF	Disables sampling of data parameters while instrument is in calibration mode. When enabled here – there is also a length of the DAS HOLD OFF after calibration mode, which is set in the VARS menu.	OFF	OFF or ON (Section 4.7.2.13)

4.7.1.2. DAS PARAMETERS

Data parameters are types of data that may be measured and stored by the DAS. For each Teledyne Instruments analyzer model, the list of available data parameters is different, fully defined and not customizable. Appendix A-5 lists firmware specific data parameters for the analyzer. DAS parameters include things like CO₂ concentration measurements, temperatures of the various heaters placed around the analyzer, pressures and flows of the pneumatic subsystem and other diagnostic measurements as well as calibration data such as slope and offset.

Most data parameters have associated measurement units, such as mV, ppb, cm³/min, etc., although some parameters have no units. With the exception of concentration readings, none of these units of measure can be changed. To change the units of measure for concentration readings see Section 4.8.6.

Note

DAS does not keep track of the unit of each concentration value, and DAS data files may contain concentrations in multiple units if the unit was changed during data acquisition.

Each data parameter has user-configurable functions that define how the data are recorded:

Table 4-8: DAS Data Parameter Functions

FUNCTION	EFFECT
PARAMETER	Instrument-specific parameter name.
SAMPLE MODE	INST: Records instantaneous reading. AVG: Records average reading during reporting interval. MIN: Records minimum (instantaneous) reading during reporting interval. MAX: Records maximum (instantaneous) reading during reporting interval. SDEV: Records the standard deviation of the data points recorded during the reporting interval.
PRECISION	Decimal precision of parameter value (0-4).
STORE NUM. SAMPLES	OFF: stores only the average (default). ON: stores the average and the number of samples in each average for a parameter. This property is only useful when the AVG sample mode is used. Note that the number of samples is the same for all parameters in one channel and needs to be specified only for one of the parameters in that channel.

Users can specify up to 50 parameters per data channel (the T360 provides about 30 parameters). However, the number of parameters and channels is ultimately limited by available memory.

4.7.1.3. DAS TRIGGERING EVENTS

Triggering events define when and how the DAS records a measurement of any given data channel. Triggering events are firmware-specific and a complete list of Triggers for this model analyzer can be found in Appendix A-5. The most commonly used triggering events are:

- **ATIMER:** Sampling at regular intervals specified by an automatic timer. Most trending information is usually stored at such regular intervals, which can be instantaneous or averaged.
- **EXITZR, EXITSP, SLPCHG** (exit zero, exit span, slope change): Sampling at the end of (irregularly occurring) calibrations or when the response slope changes. These triggering events create instantaneous data points, e.g., for the new slope and offset (concentration response) values at the end of a calibration. Zero and slope values are valuable to monitor response drift and to document when the instrument was calibrated.
- **WARNINGS:** Some data may be useful when stored if one of several warning messages appears such as **WTEMPW** (GFC wheel temperature warning) or **PPRESW** (purge pressure warning). This is helpful for troubleshooting by monitoring when a particular warning occurred.

4.7.2. Default DAS Channels

A set of default Data Channels has been included in the analyzer's software for logging CO₂ concentration and certain predictive diagnostic data. These default channels include but are not limited to:

CONC: Samples CO₂ concentration at one minute intervals and stores an average every hour with a time and date stamp. Readings during calibration and calibration hold off are not included in the data. By default, the last 800 hourly averages are stored.

PNUMTC: Collects sample flow and sample pressure data at five minute intervals and stores an average once a day with a time and date stamp. This data is useful for monitoring the condition of the pump and critical flow orifice (sample flow) and the sample filter (clogging indicated by a drop in sample pressure) over time to predict when maintenance will be required. The last 360 daily averages (about 1 year) are stored.

CALDAT: Logs new slope and offset every time a zero or span calibration is performed. This Data Channel also records the instrument readings just prior to performing a calibration. This information is useful for performing predictive diagnostics as part of a regular maintenance schedule (see Section 8.1).

STBZRO: Logs the concentration stability, the electronic output of the IR detector of the most recent measure phase and the measure/reference ratio every time the instrument exits the zero calibration mode. Data from the last 200 zero calibrations is stored. A time and date stamp is recorded for every data point logged. This information is useful for performing predictive diagnostics as part of a regular maintenance schedule (see Section 8.1).

STBSPN: Logs the electronic output of the IR detector of the most recent measure phase and the measure/reference ratio every time the instrument exits

span calibration mode. Data from the last 200 zero calibrations is stored. A time and date stamp is recorded for every data point logged. This information is useful for performing predictive diagnostics as part of a regular maintenance schedule (see Section 8.1).

TEMP: Samples the analyzer's bench temperature, box temperature and PHT cooler drive voltage every five minutes and records an average once every six hours. Data from the last 400 averaging periods is recorded. A time and date stamp is recorded for every data point logged. This information is useful for performing predictive diagnostics as part of a regular maintenance schedule (see Section 8.1).

Note

The CALDAT, STBZRO and STBSPN channels collect data based on events (e.g. a calibration operation) rather than a timed interval. This does not represent any specific length of time since it is dependent on how often calibrations are performed.

Triggering Events and Data Parameters/Functions for these default channels are:

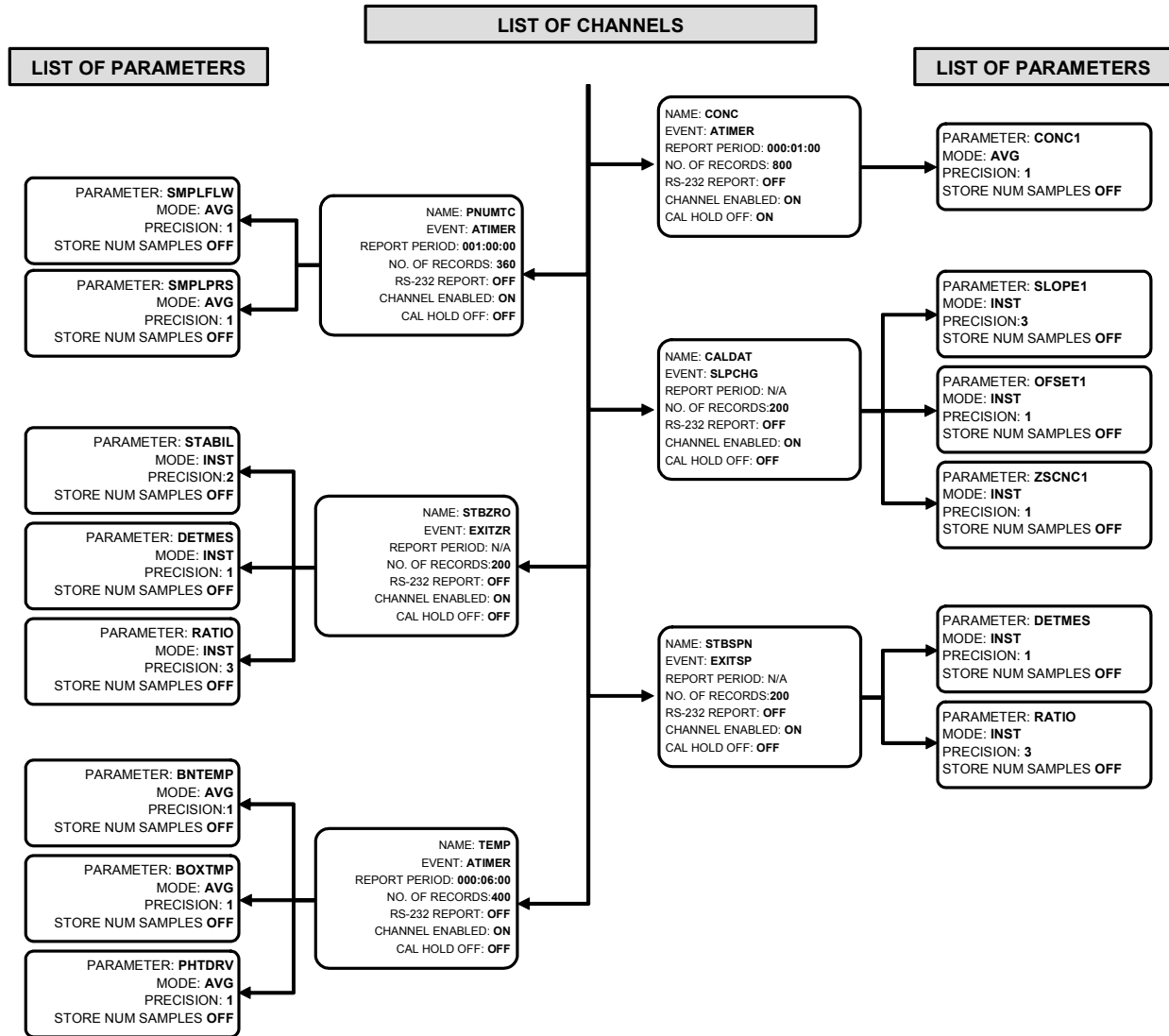

Figure 4-4: Default DAS Channels Setup

These default Data Channels can be used as they are, or they can be customized from the front panel to fit a specific application. They can also be deleted to make room for custom user-programmed Data Channels.

Appendix A-5 lists the firmware-specific DAS configuration in plain-text format. This text file can either be loaded into APICOM and then modified and uploaded to the instrument or can be copied and pasted into a terminal program to be sent to the analyzer.

NOTE

Sending a DAS configuration to the analyzer through its COM ports will replace the existing configuration and will delete all stored data. Back up any existing data and the DAS configuration before uploading new settings.

These default Data Channels can be used as they are, or they can be customized from the front panel to fit a specific application. They can also be deleted to make room for custom user-programmed Data Channels.

Appendix A-5 lists the firmware-specific DAS configuration in plain-text format. This text file can either be loaded into APICOM and then modified and uploaded to the instrument or can be copied and pasted into a terminal program to be sent to the analyzer.

NOTE

Sending a DAS configuration to the analyzer through its COM ports will replace the existing configuration and will delete all stored data. Back up any existing data and the DAS configuration before uploading new settings.

4.7.2.1. DAS CONFIGURATION LIMITS

The number of DAS objects are limited by the instrument's finite storage capacity. For information regarding the maximum number of channels, parameters, and records and how to calculate the file size for each data channel, refer to the DAS manual downloadable from the TAPI website at <http://www.teledyne-api.com/manuals/>.

4.7.2.2. VIEWING DAS DATA AND SETTINGS

DAS data and settings can be viewed on the front panel through the following touchscreen buttons sequence.

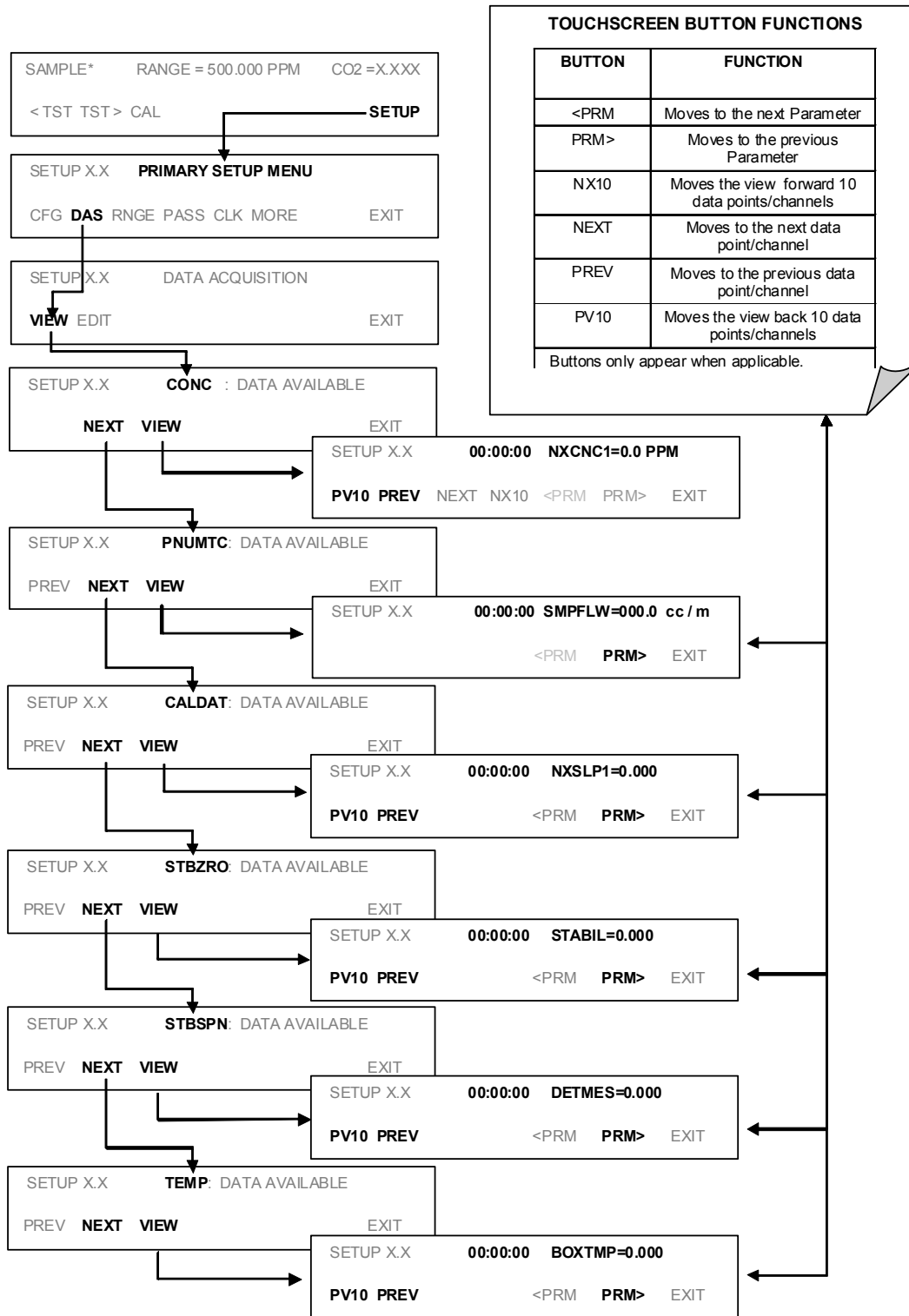

4.7.2.3. EDITING DAS DATA CHANNELS

DAS configuration is most conveniently done through the APICOM remote control program. The following list of menu buttons shows how to edit using the front panel.

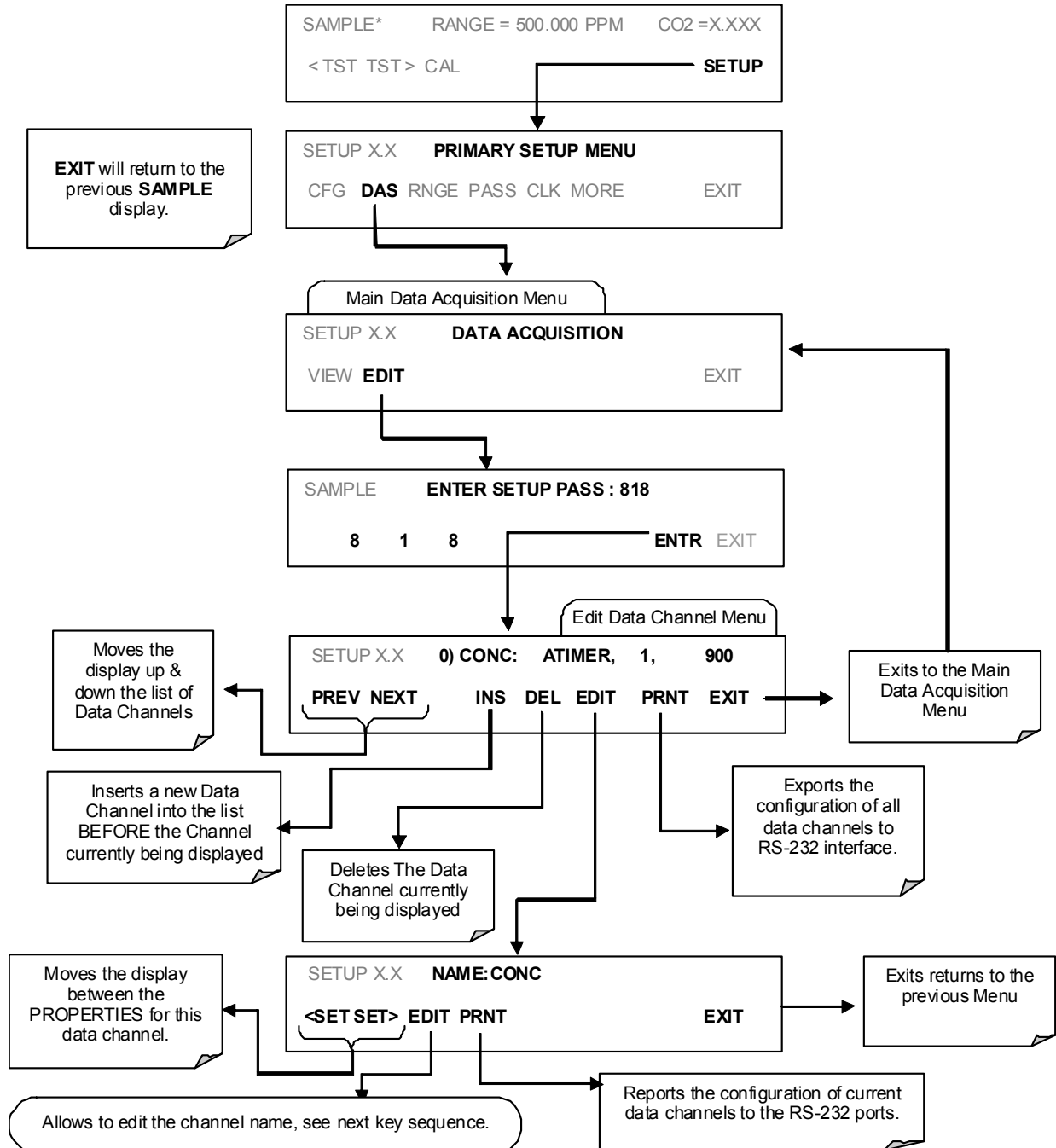

When editing the data channels, the top line of the display indicates some of the configuration parameters. For example, the display line:

0) CONC: ATIMER, 4, 800

translates to the following configuration:

Channel No.: 0

NAME: CONC

TRIGGER EVENT: ATIMER

PARAMETERS: Four parameters are included in this channel

EVENT: This channel is set up to record 800 data points.

To edit the name of a data channel, follow the above touchscreen button sequence and then press:

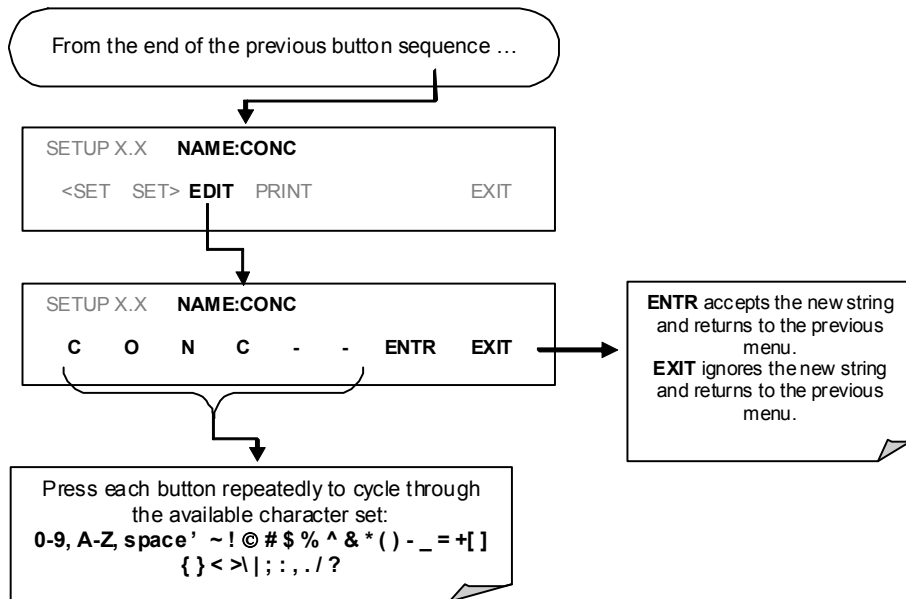

4.7.2.4. TRIGGER EVENTS

To edit the list of data parameters associated with a specific data channel, press:

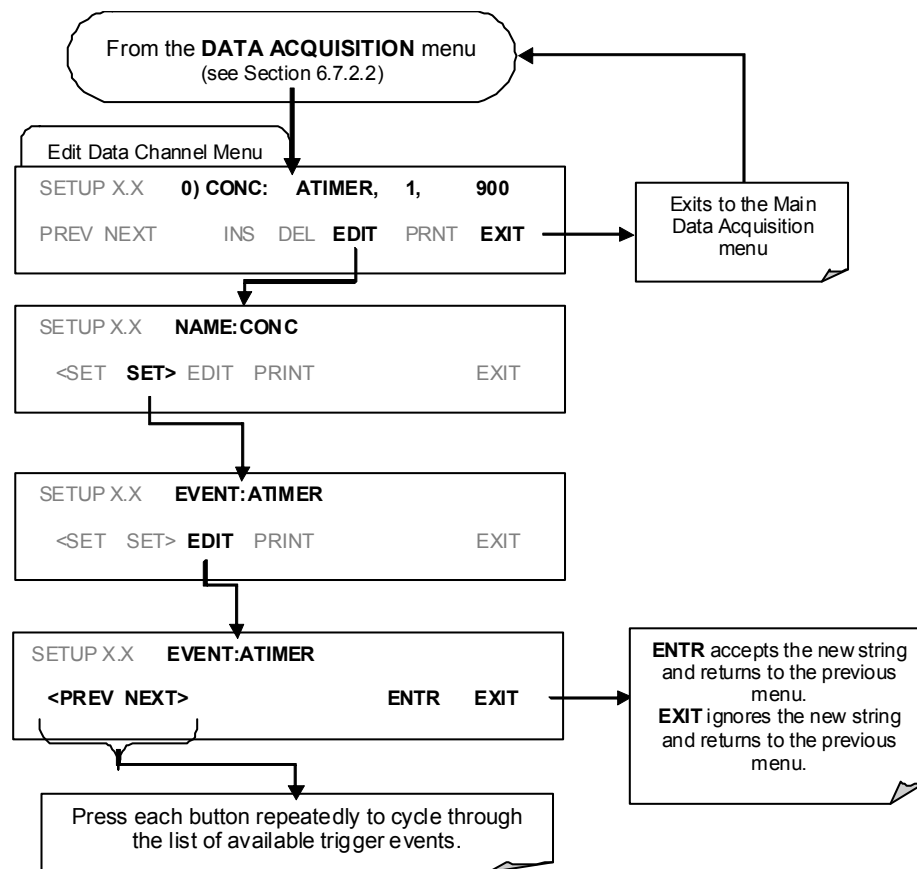

4.7.2.5. EDITING DAS PARAMETERS

Data channels can be edited individually from the front panel without affecting other data channels. However, when editing a data channel, such as during adding, deleting or editing parameters, all data for that particular channel will be lost, because the DAS can store only data of one format (number of parameter columns etc.) for any given channel. In addition, a DAS configuration can only be uploaded remotely as an entire set of channels. Hence, remote update of the DAS will always delete all current channels and stored data.

To modify, add or delete a parameter, follow the instruction shown in Section 4.7.2.2 then press:

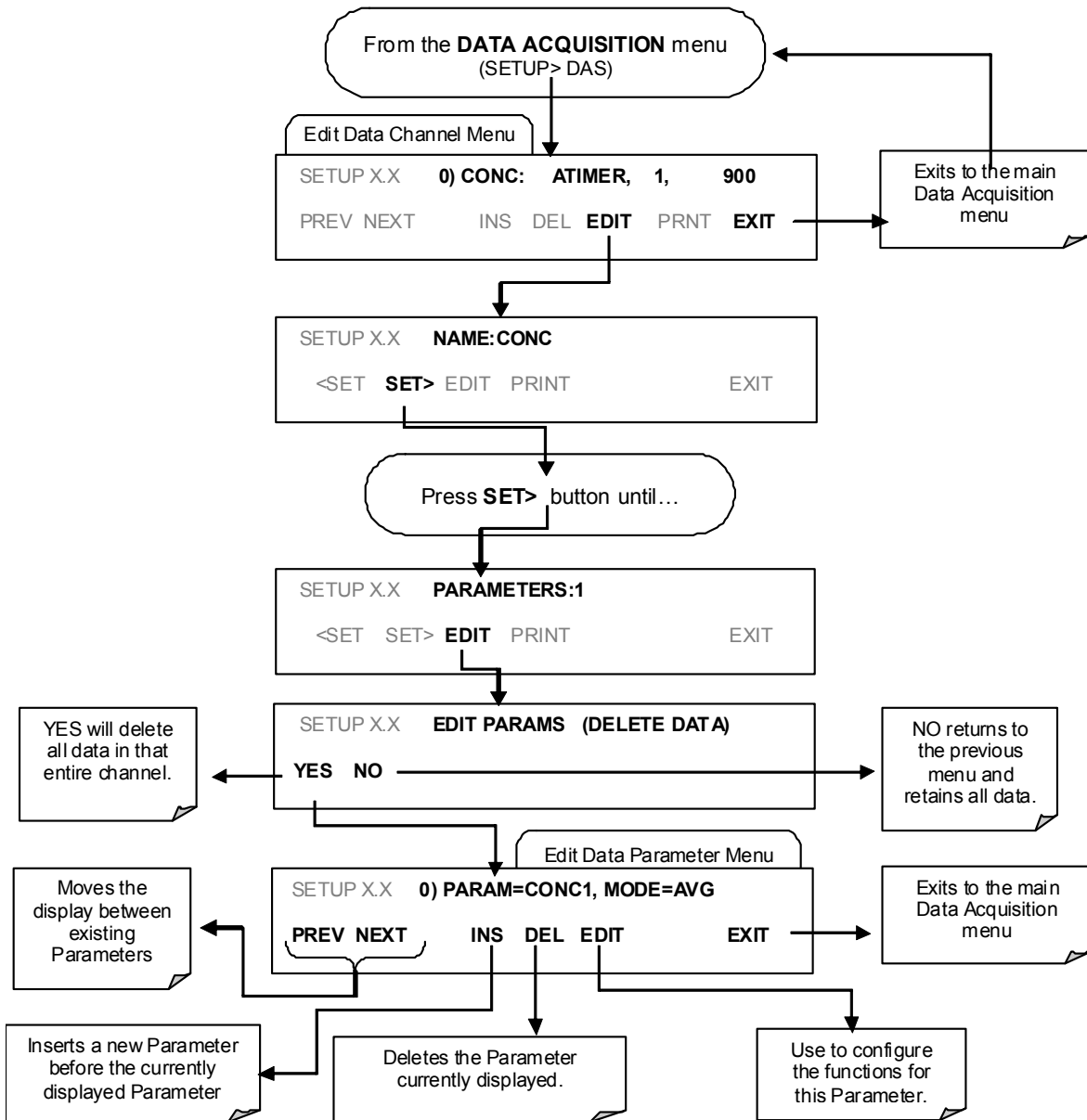

To configure a specific data parameter, press:

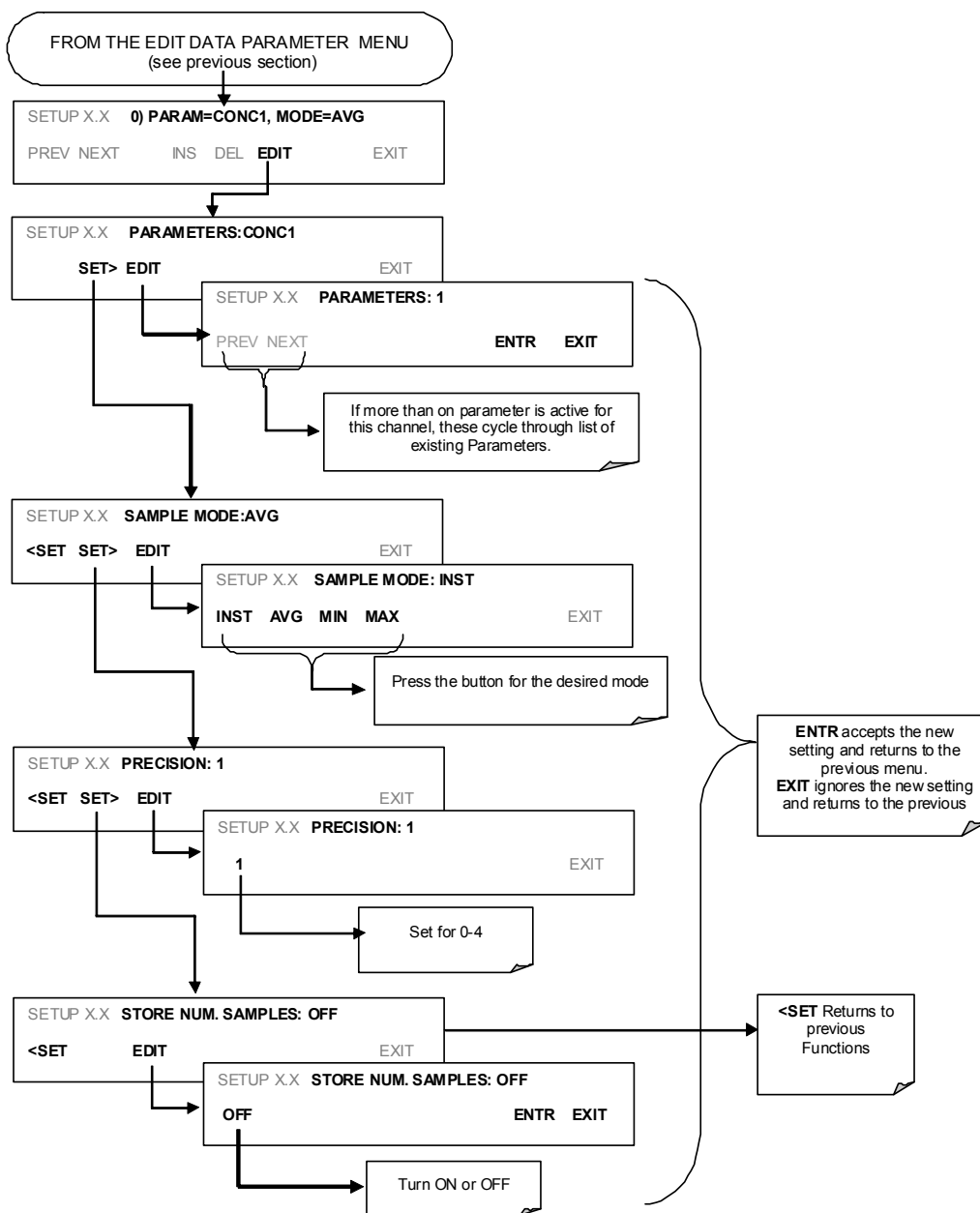

4.7.2.6. SAMPLE PERIOD AND REPORT PERIOD

The DAS defines two principal time periods by which sample readings are taken and permanently recorded: **Sample Period** and **Report Period**.

- **SAMPLE PERIOD:** Determines how often DAS temporarily records a sample reading of the parameter in volatile memory. The **SAMPLE PERIOD** is set to one minute by default and generally cannot be accessed from the standard DAS front panel menu, but is available via the instruments communication ports by using APICOM or the analyzer's standard serial data protocol.

SAMPLE PERIOD is only used when the DAS parameter's sample mode is set for **AVG**, **MIN** or **MAX**.

- **REPORT PERIOD:** Sets how often the sample readings stored in volatile memory are processed, (e.g. average, minimum or maximum are calculated) and the results stored permanently in the instruments Disk-on-Module as well as transmitted via the analyzer's communication ports. The **REPORT PERIOD** may be set from the front panel.

If the **INST** sample mode is selected the instrument stores and reports an instantaneous reading of the selected parameter at the end of the chosen **REPORT PERIOD**

In **AVG**, **MIN** or **MAX** sample modes, the settings for the **SAMPLE PERIOD** and the **REPORT PERIOD** determine the number of data points used each time the average, minimum or maximum is calculated, stored and reported to the com ports. The actual sample readings are not stored past the end of the of the chosen **REPORT PERIOD**.

Also, the **SAMPLE PERIOD** and **REPORT PERIOD** intervals are synchronized to the beginning and end of the appropriate interval of the instruments internal clock.

- If **SAMPLE PERIOD** were set for one minute the first reading would occur at the beginning of the next full minute according to the instrument's internal clock.
- If the **REPORT PERIOD** were set for of one hour the first report activity would occur at the beginning of the next full hour according to the instrument's internal clock.

EXAMPLE: Given the above settings, if DAS were activated at 7:57:35 the first sample would occur at 7:58 and the first report would be calculated at 8:00 consisting of data points for 7:58, 7:59 and 8:00.

During the next hour (from 8:01 to 9:00) the instrument will take a sample reading every minute and include 60 sample readings.

When the **STORE NUM SAMPLES** feature is turned on, the instrument will also store how many sample readings were used for the **AVG**, **MIN** or **MAX** calculation but not the readings themselves.

4.7.2.7. REPORT PERIODS IN PROGRESS WHEN INSTRUMENT IS POWERED OFF

If the instrument is powered off in the middle of a **REPORT PERIOD**, the samples accumulated so far during that period are lost. Once the instrument is turned back on, the DAS restarts taking samples and temporarily them in volatile memory as part of the **REPORT PERIOD** currently active at the time of restart. At the end of this **REPORT PERIOD** only the sample readings taken since the instrument was turned back on will be included in any **AVG**, **MIN** or **MAX** calculation. Also, the **STORE NUM. SAMPLES** feature will report the number of sample readings taken since the instrument was restarted.

To define the **REPORT PERIOD**, follow the instruction shown in Section 4.7.2.2 then press:

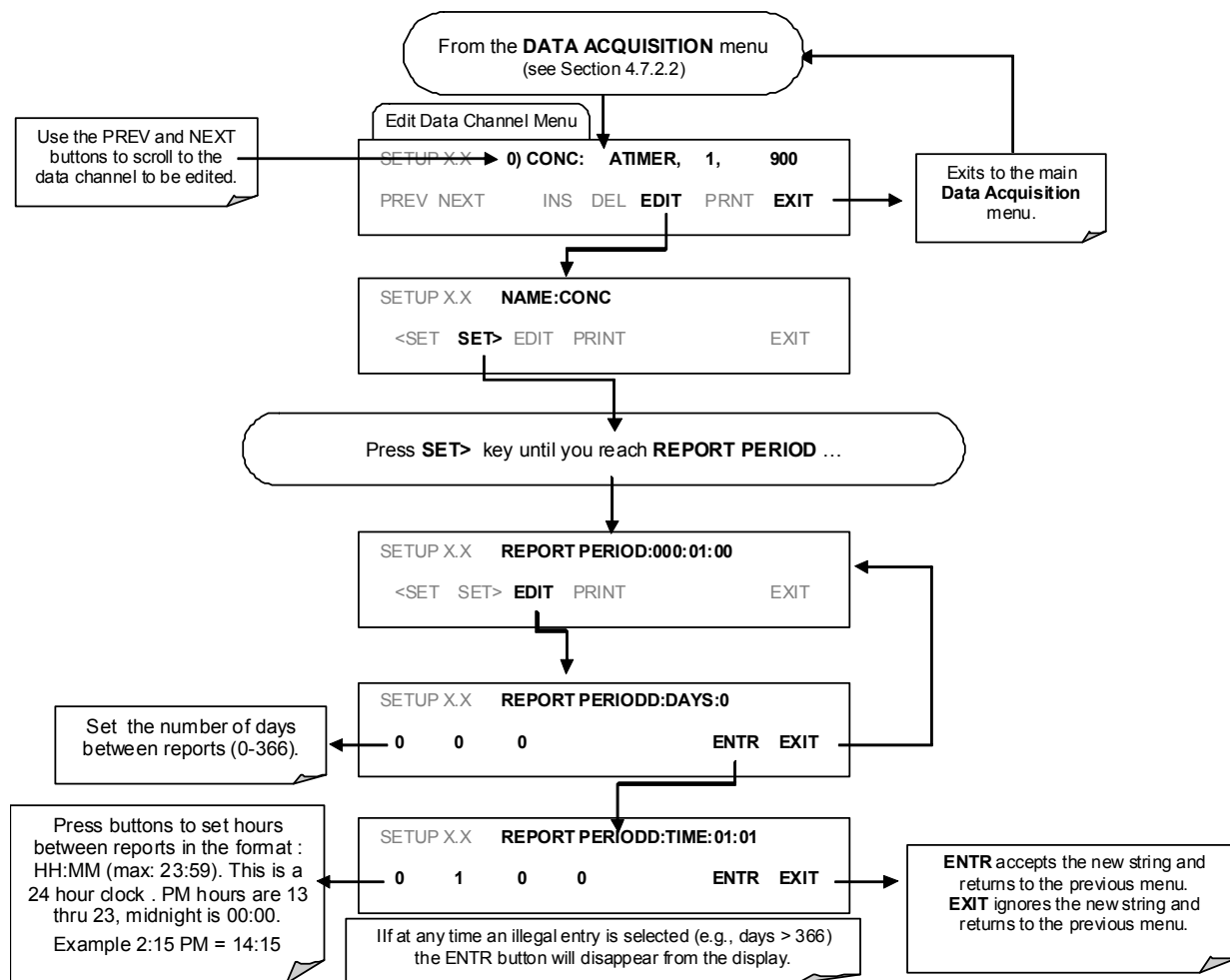

4.7.2.8. NUMBER OF RECORDS

Although the DAS can capture several months worth of data, the number of data records in the T360 is limited by the total number of parameters and channels and other settings in the DAS configuration. Every additional data channel, parameter, number of samples setting etc. will reduce the maximum amount of data points somewhat. In general, however, the maximum data capacity is divided amongst all channels (max: 20) and parameters (max: 50 per channel).

The DAS will check the amount of available data space and prevent the user from specifying too many records at any given point. If, for example, the DAS memory space can accommodate 375 more data records, the ENTR key will disappear when trying to specify more than that number of records. This check for memory space may also make an upload of a DAS configuration with APICOM or a Terminal program fail, if the combined number of records would be exceeded. In this case, it is suggested to either try from the front panel what the maximum number of records can be or use trial-and-error in designing the DAS script or calculate the number of records using the DAS or APICOM manuals. To set the number of records for one channel from the front panel, press SETUP-DAS-EDIT-ENTR and the following touchscreen button sequence.

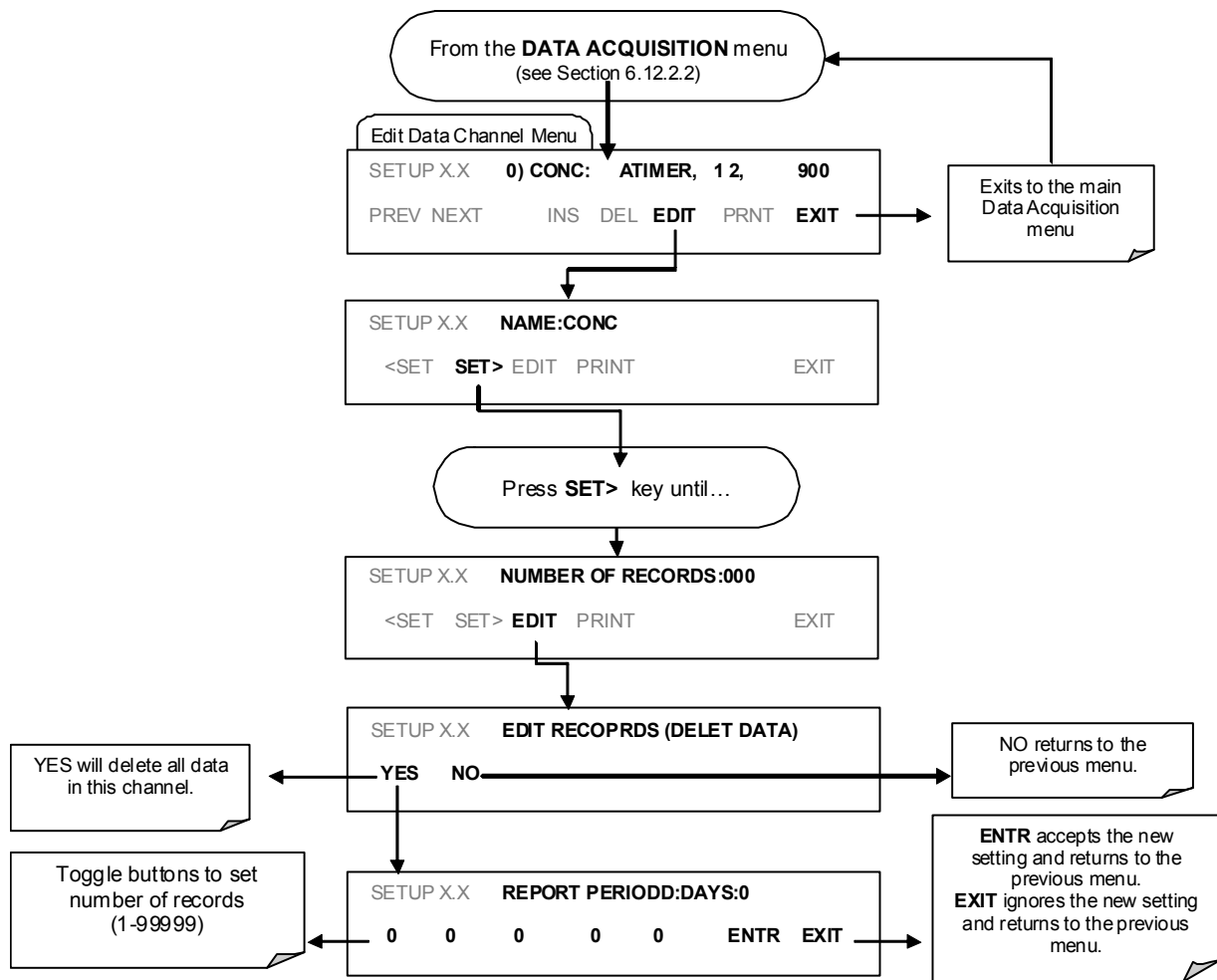

4.7.2.9. RS-232 REPORT FUNCTION

The T360 DAS can automatically report data to the communications ports, where they can be captured with a terminal emulation program or simply viewed by the user.

To enable automatic COM port reporting, follow the instruction shown in Section 4.7.2.2 then press:

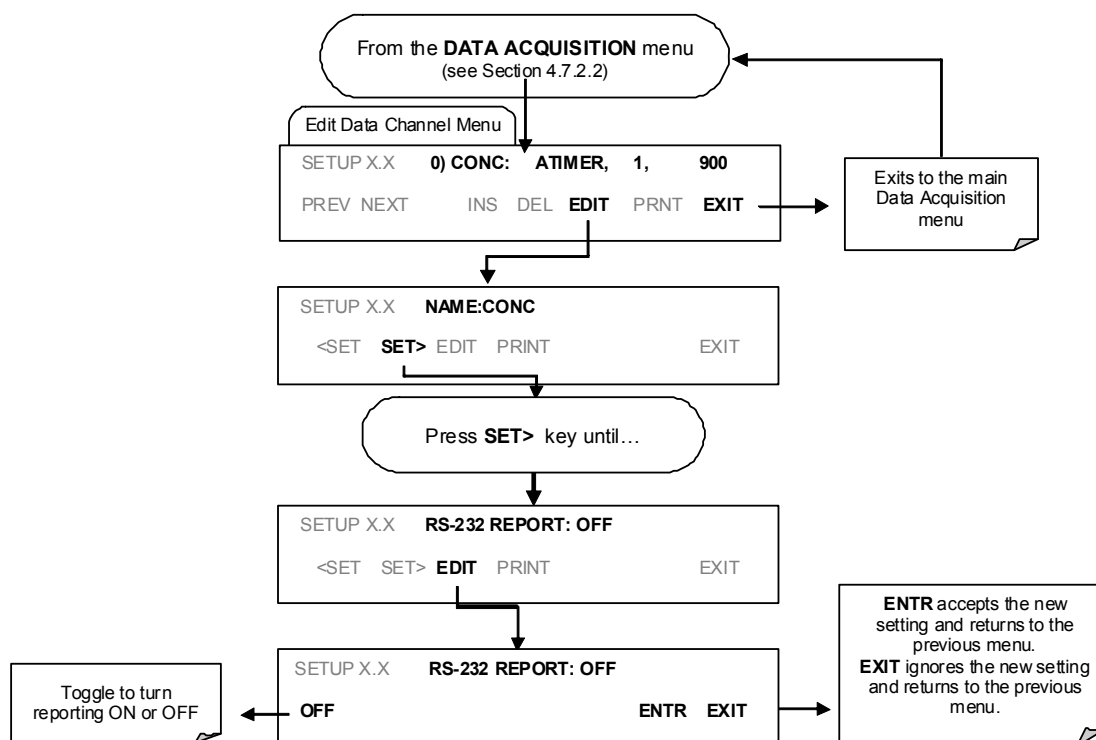

4.7.2.10. COMPACT REPORT

When enabled, this option avoids unnecessary line breaks on all RS-232 reports. Instead of reporting each parameter in one channel on a separate line, up to five parameters are reported in one line.

4.7.2.11. STARTING DATE

This option allows to specify a starting date for any given channel in case the user wants to start data acquisition only after a certain time and date. If the **Starting Date** is in the past, the DAS ignores this setting.

4.7.2.12. DISABLING/ENABLING DATA CHANNELS

Data channels can be temporarily disabled, which can reduce the read/write wear on the disk-on-chip. The ALL_01 channel of the T360, for example, is disabled by default.

To disable a data channel, follow the instruction shown in Section 4.7.2.2 then press:

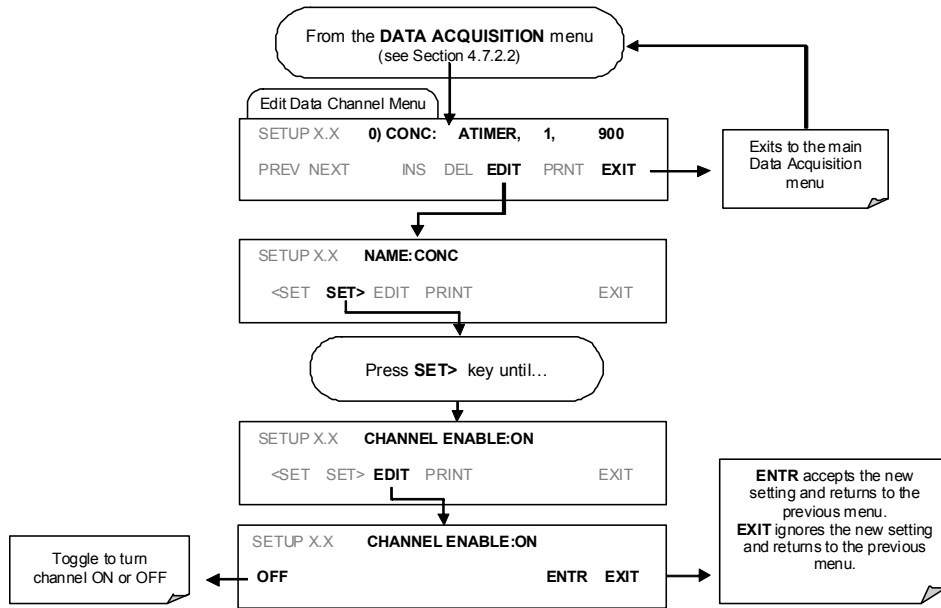

4.7.2.13. HOLDOFF FEATURE

The DAS HOLDOFF feature allows to prevent data collection during calibrations and during the **DAS_HOLDOFF** period enabled and specified in the VARS (Section 4.12). To enable or disable the HOLDOFF, follow the instruction shown in Section 4.7.2.2 then press:

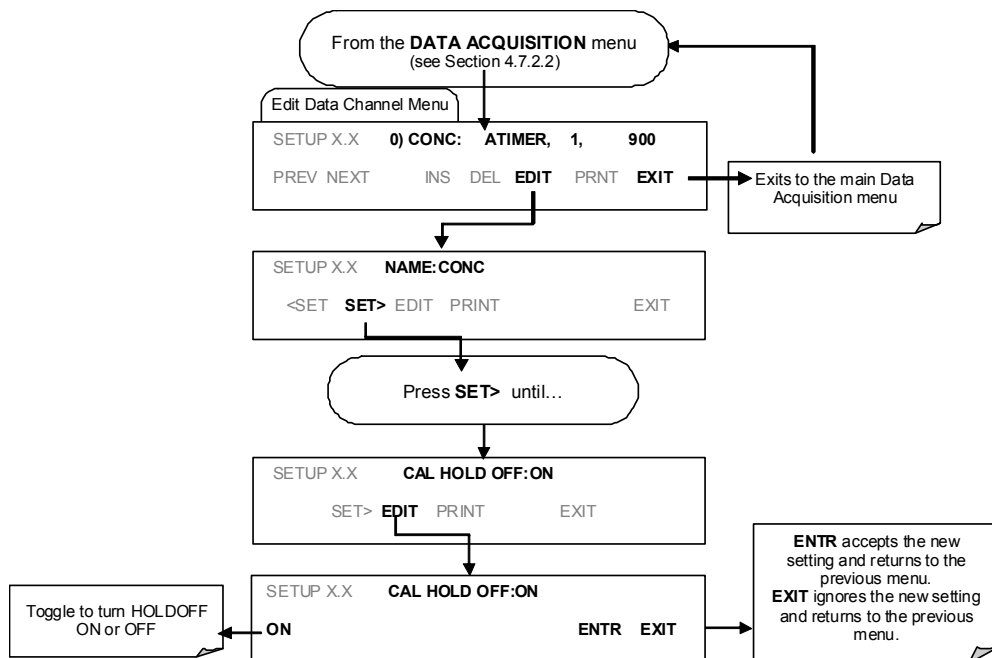

4.7.3. Remote DAS Configuration

Editing channels, parameters and triggering events as described in this can be performed via the APICOM remote control program using the graphic interface shown in Figure 4-5. Refer to Section 4.15 for details on remote access to the T360 analyzer.

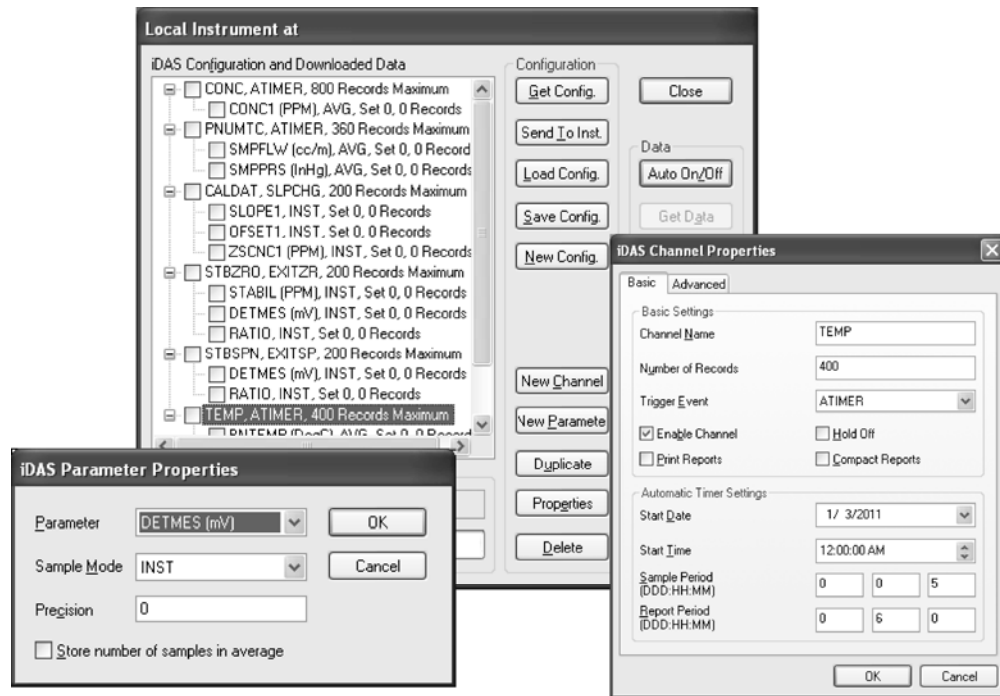

Figure 4-5: APICOM User Interface for DAS Configuration

Once a DAS configuration is edited (which can be done offline and without interrupting DAS data collection), it is conveniently uploaded to the instrument and can be stored on a computer for later review, alteration or documentation and archival. Refer to the APICOM manual for details on these procedures. The APICOM user manual (Teledyne Instruments part number 039450000) is included in the APICOM installation file, which can be downloaded at <http://www.teledyne-api.com/software/apicom/>. It is recommended that you start by downloading the default DAS configuration, getting familiar with its command structure and syntax conventions, and then altering a copy of the original file offline before uploading the new configuration.

CAUTION

Whereas the editing, adding and deleting of DAS channels and parameters of one channel through the front-panel touchscreen can be done without affecting the other channels, uploading a DAS configuration script to the analyzer through its communication ports will erase all data, parameters and channels by replacing them with the new DAS configuration. Backup of data and the original DAS configuration is advised before attempting any DAS changes.

4.8. SETUP → RNGE: ANALOG OUTPUT REPORTING RANGE CONFIGURATION

The analyzer has three active analog output signals, accessible through a connector on the rear panel.

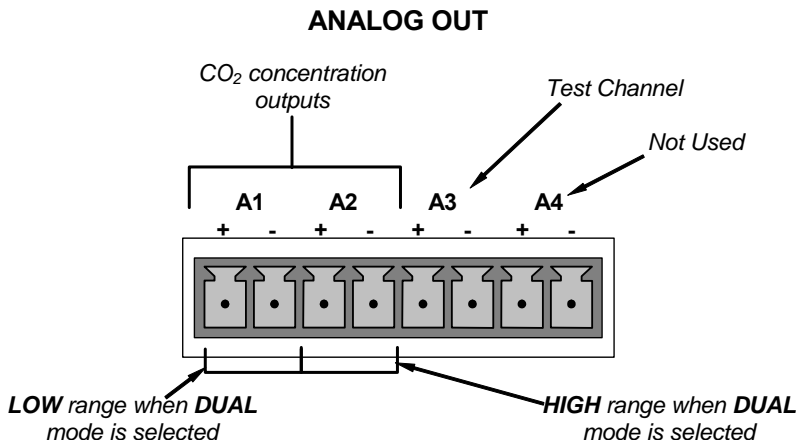

Figure 4-6: Analog Output Connector Pin Out

All three outputs can be configured either at the factory or by the user for full scale outputs of 0.1 VDC, 1VDC, 5VDC or 10VDC. Additionally **A1** and **A2** may be equipped with optional 0-20 mA DC current loop drivers and configured for any current output within that range (e.g. 0-20, 2-20, 4-20, etc.). The user may also adjust the signal level and scaling of the actual output voltage or current to match the input requirements of the recorder or data logger (See Section 4.13.4).

The **A1** and **A2** channels output a signal that is proportional to the CO₂ concentration of the sample gas. Several modes are available which allow them to operate independently or be slaved together. The user may also select between a variety of reporting range spans (see Section 4.8).

EXAMPLE:

A1 OUTPUT: Output Signal = 0-5 VDC representing 0-1000 ppm concentration values

A2 OUTPUT: Output Signal = 0 – 10 VDC representing 0-500 ppm concentration values.

Output **A3** is only active if the O₂ sensor option is installed. In this case a signal representing the currently measured O₂ concentration is output on this channel.

The output, labeled **A4** is special. It can be set by the user (See Section 4.13.9) to output several of the test functions accessible through the <TST TST> buttons of the units sample display.

4.8.1. Physical Range versus Analog Output Reporting Ranges

Functionally, the Gas Filter Correlation CO₂ Analyzer has one hardware Physical Range that is capable of determining CO₂ concentrations between 50 ppm and 2,000 ppm. This architecture improves reliability and accuracy by avoiding the need for extra, switchable, gain-amplification circuitry. Once properly calibrated, the analyzer's front panel will accurately report concentrations along the entire span of its 50 ppm and 2,000 ppm physical range.

Because, most applications use only a small part of the analyzer's physical range, the width of the Model T360's physical range can create data resolution problems for most analog recording devices. For example, in an application where the expected concentration of CO₂ is typically less than 500 ppm, the full scale of expected values is only 25% of the instrument's 2,000 ppm physical range. Unmodified, the corresponding output signal would also be recorded across only 25% of the range of the recording device.

The T360 solves this problem by allowing the user to select a scaled reporting range for the analog outputs that only includes that portion of the physical range relevant to the specific application. Only the reporting range of the analog outputs is scaled, the physical range of the analyzer and the readings displayed on the front panel remain unaltered.

4.8.2. Reporting Range Modes

The T360 provides three analog output range modes to choose from.

- Single range (**SNGL**) mode sets a single maximum range for the analog output. If single range is selected (see Section 4.8.3) both outputs are slaved together and will represent the same measurement span (e.g. 0-50 ppm), however their electronic signal levels may be configured for different ranges (e.g. 0-10 VDC vs. 0-.1 VDC – see Section 4.13.4).
- Dual range (**DUAL**) allows the A1 and A2 outputs to be configured with different measurement spans (see Section 4.8.4) as well as separate electronic signal levels (see Section 4.13.4).
- Auto range (**AUTO**) mode gives the analyzer the ability to output data via a low range and high range. When this mode is selected (see Section 4.8.5) the T360 will automatically switch between the two ranges dynamically as the concentration value fluctuates.

Range status is also output via the external digital I/O status outputs (see Section 4.15.1).

To select the Analog Output Range Type press:

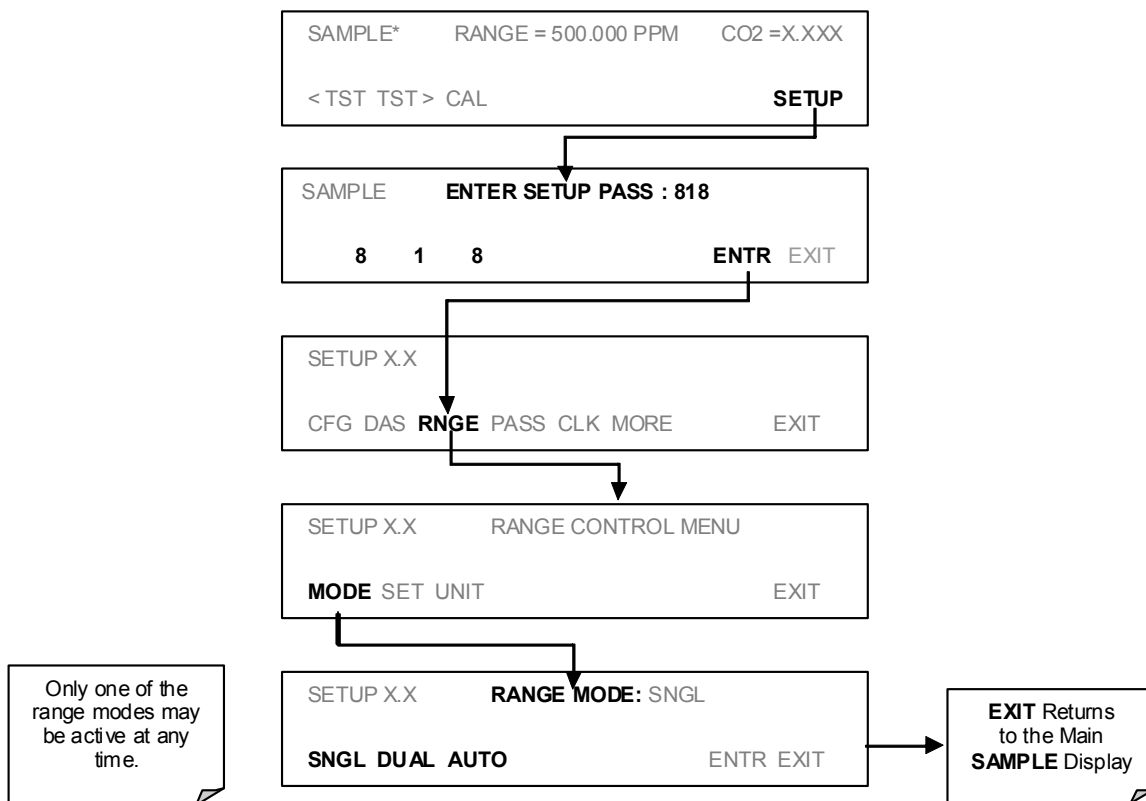

NOTE

Upper span limit setting for the individual range modes are shared. Resetting the span limit in one mode also resets the span limit for the corresponding range in the other modes as follows:

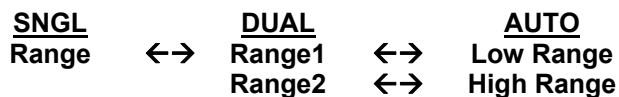

4.8.3. Single Range Mode (SNGL)

This is the default reporting range mode for the analyzer. In single range mode both **A1** and **A2** are set to the same reporting range. This reporting range can be any value between 50 ppm and 2 000 ppm.

While the two outputs always have the same reporting range, the span, signal offset and scaling of their electronic signals may be configured for differently (e.g., **A1** = 0-10 V; **A2** = 0-0.1 V). See Section 4.13.4 for instructions on adjusting these parameters.

To select **SNGL** range mode and to set the upper limit of the range, press:

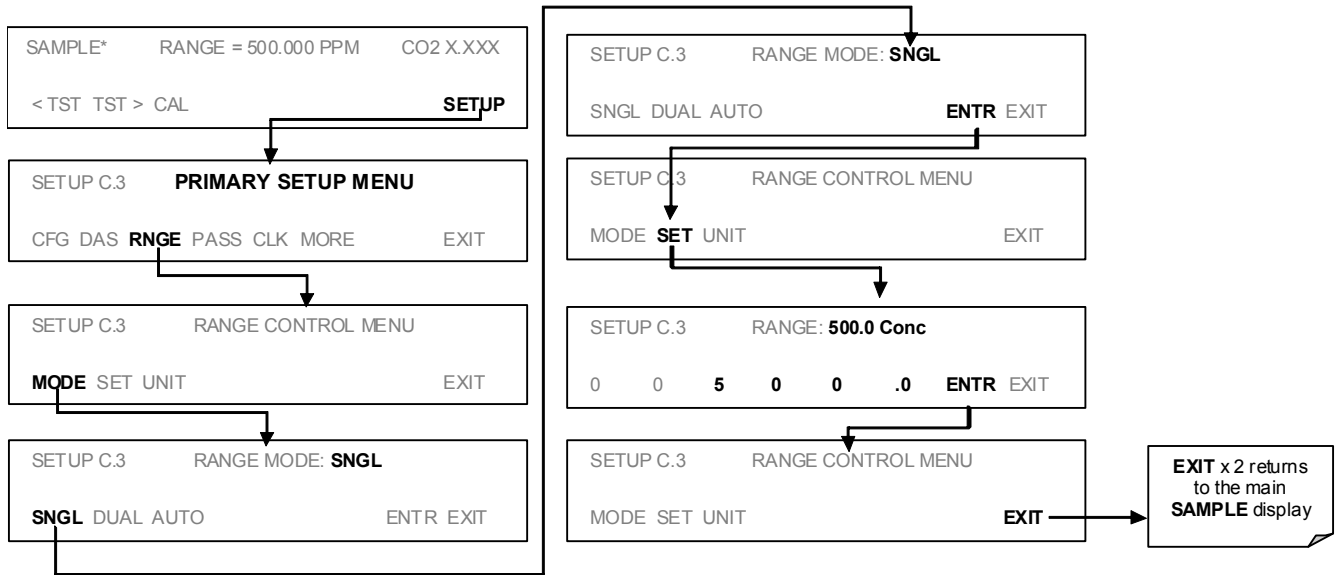

4.8.4. Dual Range Mode (DUAL)

Selecting Dual Range mode allows the **A1** and **A2** outputs to be configured with different reporting ranges. The analyzer software calls these two ranges low and high. The low range setting corresponds with the analog output labeled **A1** on the Rear Panel of the instrument. The high Range Setting corresponds with the **A2** output. While the software names these two ranges low and high, they do not have to be configured that way. For example: The low range can be set for a span of 0-1000 ppm while the high range is set for 0-500 ppm.

In **DUAL** range mode the **RANGE** test function displayed on the front panel will be replaced by two separate functions:

- **RANGE1**: The range setting for the **A1** output.
- **RANGE2**: The range setting for the **A2** output.

To set the ranges press following menu button sequence

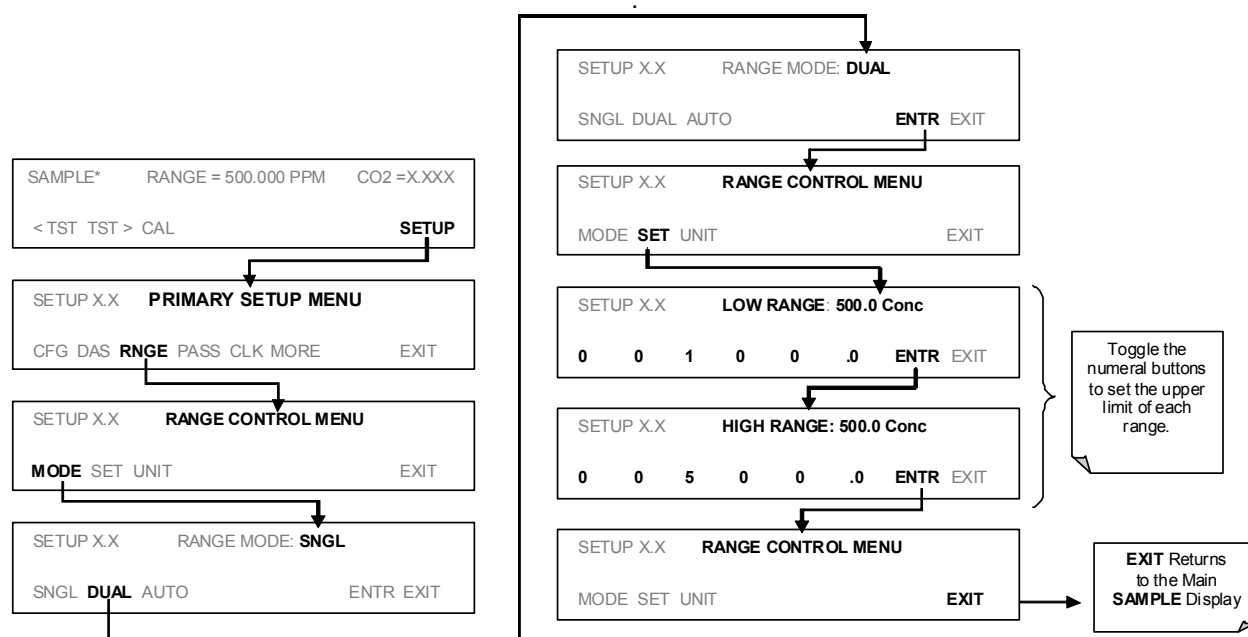

When the instrument's range mode is set to **DUAL** the concentration field in the upper right hand corner of the display alternates between displaying the low range value and the high range value. The concentration currently being displayed is identified as follows: C1 = Low (or **A1**) and C2 = High (or **A2**).

NOTE

In **DUAL** range mode the **LOW** and **HIGH** ranges have separate slopes and offsets for computing **CO₂** concentration.

The two ranges must be independently calibrated.

4.8.5. Auto Range Mode (AUTO)

In **AUTO** range mode, the analyzer automatically switches the reporting range between two user-defined ranges (low and high). The unit will switch from low range to high range when the CO₂ concentration exceeds 98% of the low range span. The unit will return from high range back to low range once both the CO₂ concentration falls below 75% of the low range span.

In **AUTO** Range mode the instrument reports the same data in the same range on both the **A1** and **A2** outputs and automatically switches both outputs between ranges as described above. Also, the **RANGE** test function displayed on the front panel will automatically switch to show which range is in effect.

The high/low range status is also reported through the external, digital status outputs (Section 4.15.1).

To set individual ranges press the following menu button sequence.

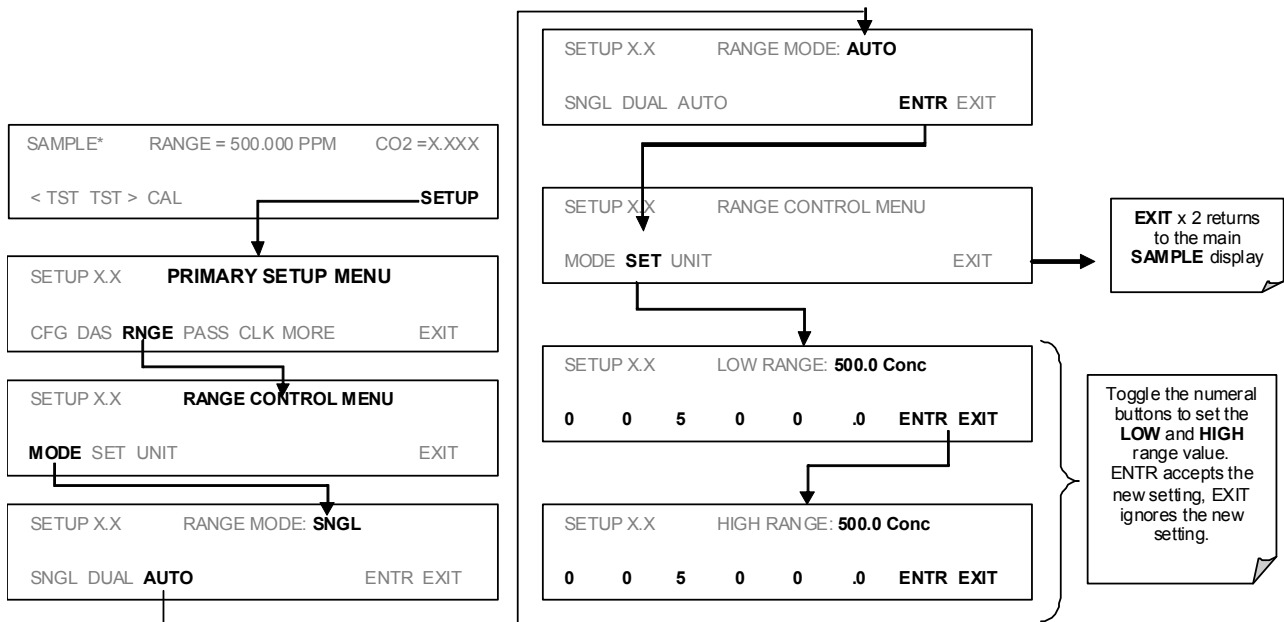

NOTE

In AUTO range mode the LOW and HIGH ranges have separate slopes and offsets for computing CO₂ concentration. The two ranges must be independently calibrated.

NOTE

Avoid accidentally setting the low range of the instrument with a higher span limit than the high range. This will cause the unit to stay in the low reporting range perpetually and defeat the function of the AUTO range mode.

4.8.6. Range Units

The T360 can display concentrations in parts per billion (10^9 mols per mol, **PPB**), parts per million (10^6 mols per mol, **PPM**), micrograms per cubic meter ($\mu\text{g}/\text{m}^3$, **UG**), milligrams per cubic meter (mg/m^3 , **MG**) or percent (volume CO_2 /volume sample gas, **%**). Changing units affects all of the display, analog outputs, COM port and DAS values for all reporting ranges regardless of the analyzer's range mode.

NOTE

Concentrations displayed in mg/m^3 and $\mu\text{g}/\text{m}^3$ use 0°C , 760 mmHg for Standard Temperature and Pressure (STP). Consult your local regulations for the STP used by your agency.

Conversion factors from volumetric to mass units are:

$$\text{CO}_2: \text{ppb} \times 1.96 = \mu\text{g}/\text{m}^3; \text{ppm} \times 1.96 = \text{mg}/\text{m}^3$$

To change the concentration units:

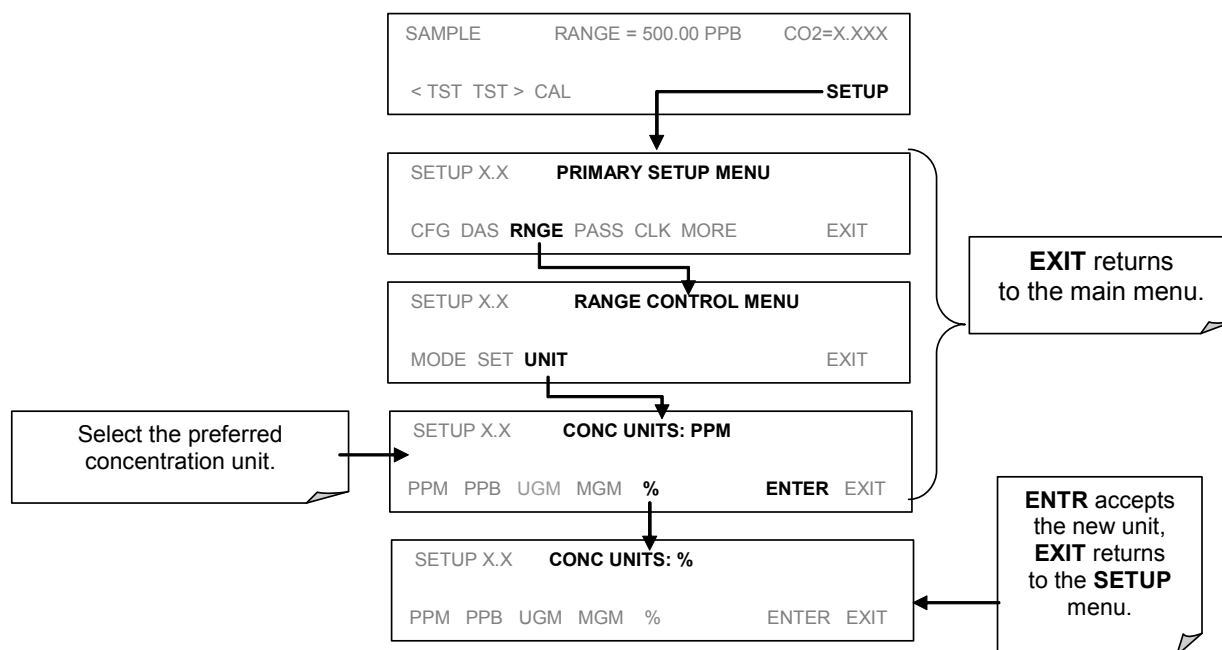

NOTE

Once the units of measurement have been changed the unit **MUST** be recalibrated, as the "expected span values" previously in effect will no longer be valid. Simply entering new expected span values without running the entire calibration routine is not sufficient.

4.8.7. Dilution Ratio

The dilution ratio is a software option that allows the user to compensate for any dilution of the sample gas before it enters the sample inlet. Using the dilution ratio option is a 4-step process:

1. Select reporting range units (Section 4.8.6).
2. Select the range: Use the procedures in Sections 4.8.2 – 4.8.5. Make sure that the **SPAN** value entered is the maximum expected concentration of the undiluted calibration gas and that the span gas is either supplied through the same dilution inlet system as the sample gas or has an appropriately lower actual concentration. For example, with a dilution set to 100, a 10 ppm gas can be used to calibrate a 1000 ppm sample gas if the span gas is not routed through the dilution system. On the other hand, if a 1000 ppm span gas is used, it needs to pass through the same dilution steps as the sample gas.
3. Set the dilution factor as a gain (e.g., a value of 20 means 20 parts diluting gas and 1 part of sample gas):

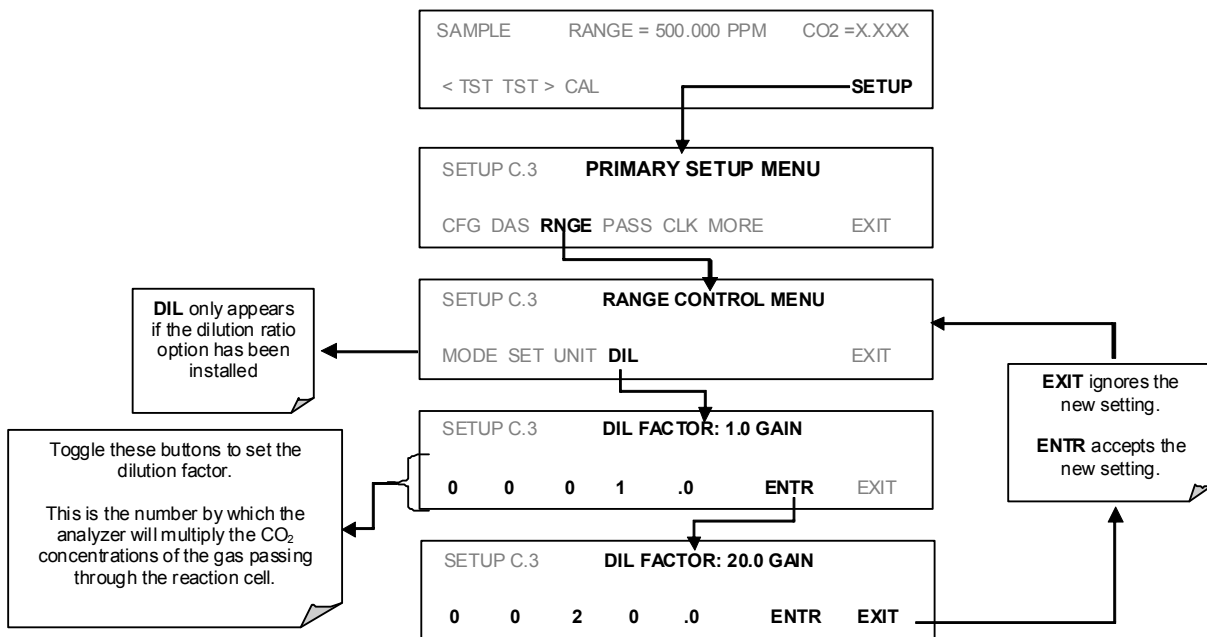

The analyzer multiplies the measured gas concentrations with this dilution factor and displays the result.

NOTE

Once the above settings have been entered, the instrument needs to be recalibrated using one of the methods discussed in Section 5.

4.9. SETUP → PASS: PASSWORD FEATURE

The T360 provides password protection of the calibration and setup functions to prevent unauthorized adjustments. When the passwords have been enabled in the **PASS** menu item, the system will prompt the user for a password anytime a password-protected function (e.g., **SETUP**) is selected. This allows normal operation of the instrument, but requires the password (101) to access to the menus under **SETUP**. When **PASSWORD** is disabled (**SETUP>OFF**), any operator can enter the Primary Setup (**SETUP**) and Secondary Setup (**SETUP>MORE**) menus. Whether **PASSWORD** is enabled or disabled, a password (default 818) is required to enter the **VARs** or **DIAG** menus in the **SETUP>MORE** menu.

There are three levels of password protection, which correspond to operator, maintenance, and configuration functions. Each level allows access to all of the functions in the previous level.

Table 6-9: Password Levels

Password	Level	Menu Access Allowed
Null (000)	Operation	All functions of the MAIN menu: TEST, GEN, initiate SEQ, MSG, CLR
101	Configuration/Maintenance	Access to Primary Setup and Secondary SETUP Menus when PASSWORD is enabled.
818	Configuration/Maintenance	Access to Secondary SETUP Submenus VARs and DIAG whether PASSWORD is enabled or disabled.

To enable or disable passwords, press the following menu button sequence:

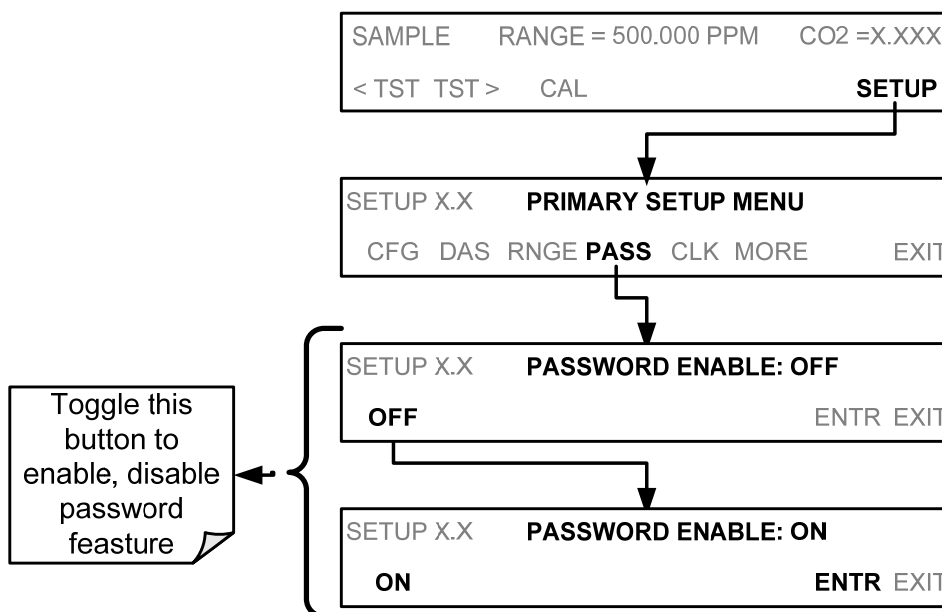

Example: If all passwords are enabled, the following menu button sequence would be required to enter the SETUP menu:

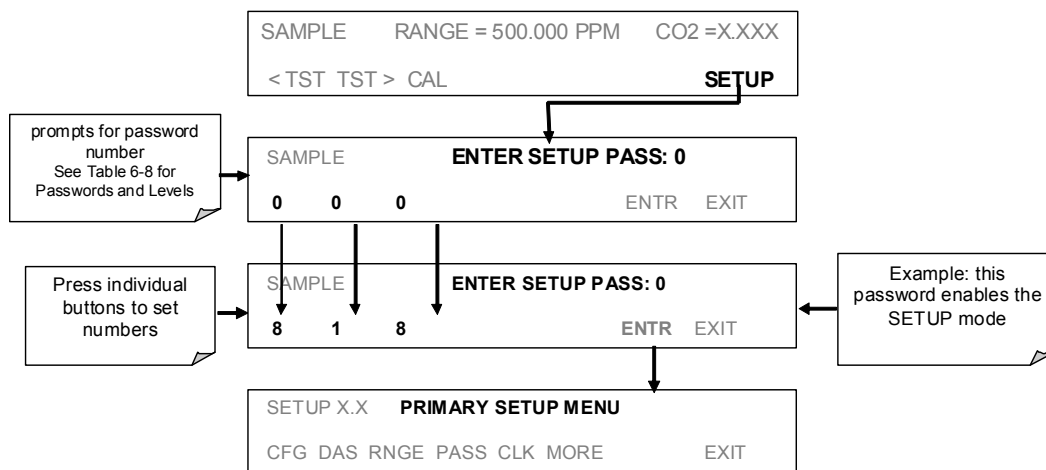

Note that the instrument still prompts for a password when entering the VARS and DIAG menus, even if passwords are disabled, but it displays the default password (818) upon entering these menus. The user only has to press ENTR to access the password-protected menus but does not have to enter the required number code.

4.10. SETUP → CLK: SETTING THE INTERNAL TIME-OF-DAY CLOCK

The T360 has a time of day clock that supports the AutoCal timer, time of day TEST function, and time stamps on most COM port messages. To set the time-of-day, press:

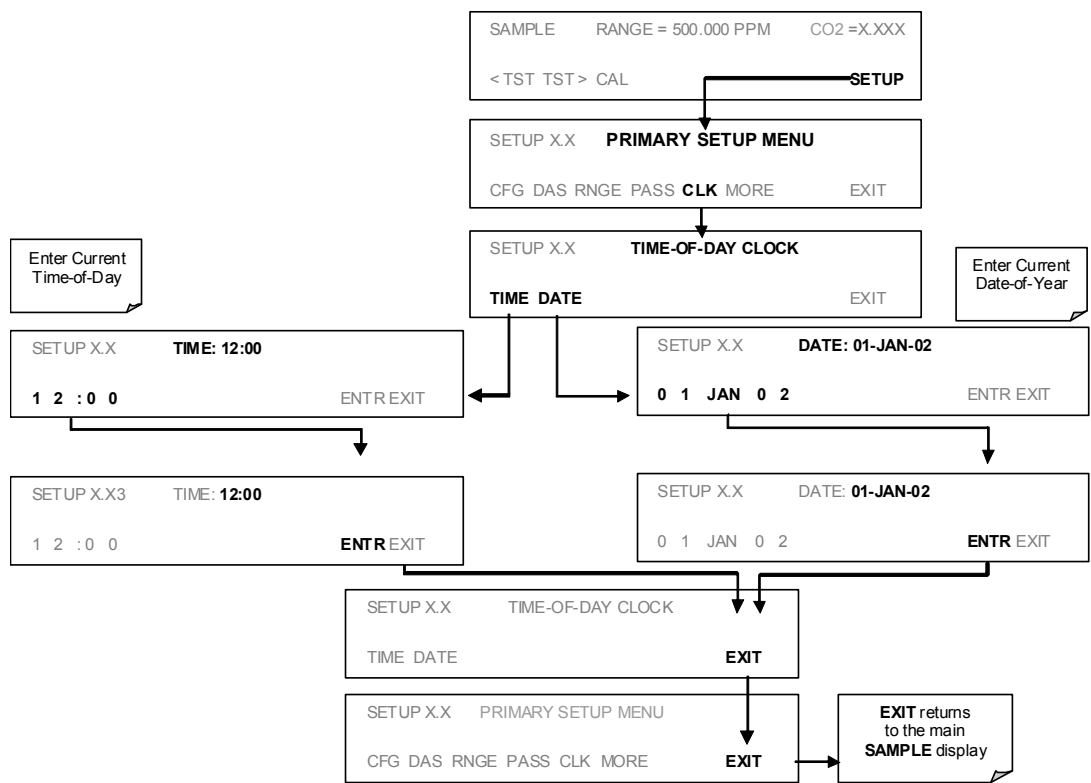

In order to compensate for CPU clocks which run faster or slower, you can adjust a variable called **CLOCK_ADJ** to speed up or slow down the clock by a fixed amount every day. To change this variable, press:

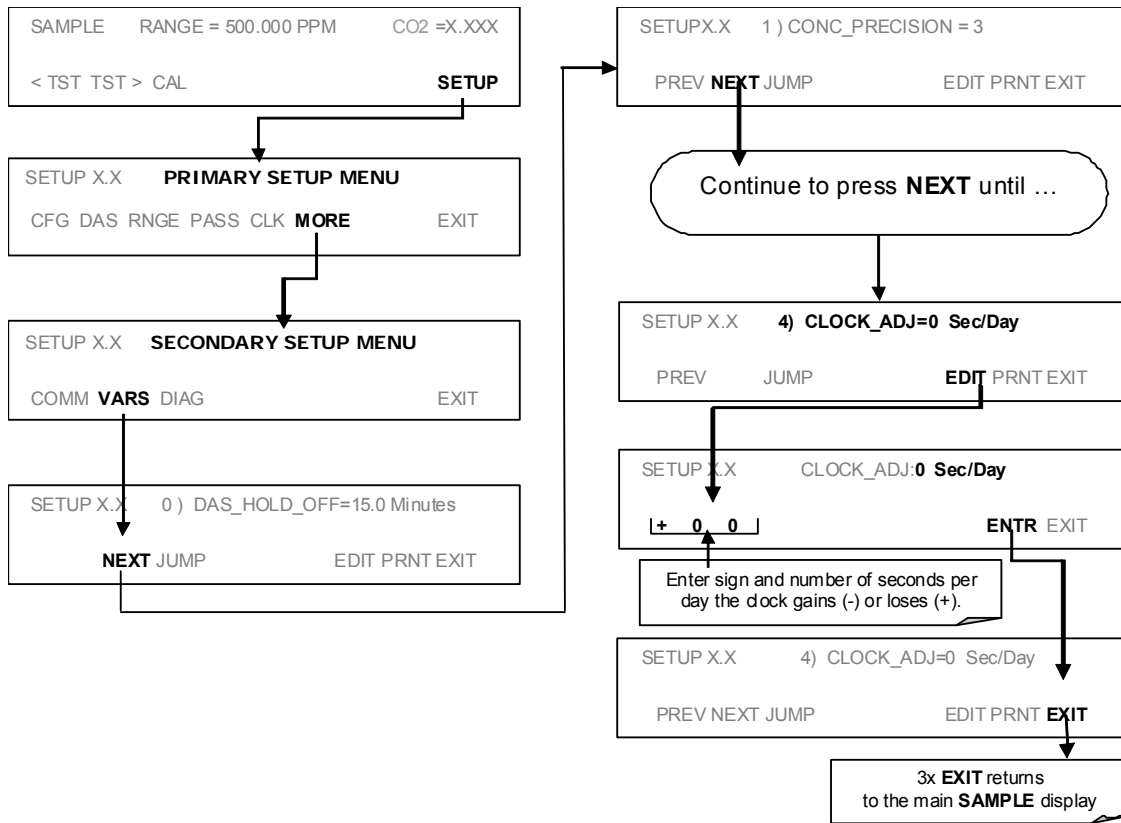

4.11. SETUP → MORE → COMM: USING THE ANALYZER'S COMMUNICATION PORTS

The T360 is equipped with an Ethernet port, a USB port and two serial communication (COM) ports located on the rear panel (Figure 3-4). Both com ports operate similarly and give the user the ability to communicate with, issue commands to, and receive data from the analyzer through an external computer system or terminal.

By default, both com ports operate on the RS-232 protocol.

- The RS232 port (used as COM1) can also be configured to operate in single or RS-232 multidrop mode (option 62; see Section 4.11.8).
- The COM2 port can be configured for standard RS-232 operation or half-duplex RS-485 communication (For RS-485 communication, please contact the factory).

A code-activated switch (CAS), can also be used on either port to connect typically between 2 and 16 send/receive instruments (host computer(s) printers, data loggers, analyzers, monitors, calibrators, etc.) into one communications hub. Contact Teledyne Instruments sales for more information on CAS systems.

4.11.1. Machine ID

Each type of Teledyne Instruments analyzer is configured with a default ID code. The default ID code for all T360 analyzers is either **360** or **0**. The ID number is only important if more than one analyzer is connected to the same communications channel such as when several analyzers are on the same Ethernet LAN (see Section 4.11.6); in a RS-232 multidrop chain (see Section 4.11.8) or operating over a RS-485 network. If two analyzers of the same model type are used on one channel, the ID codes of one or both of the instruments needs to be changed.

To edit the instrument's ID code, press:

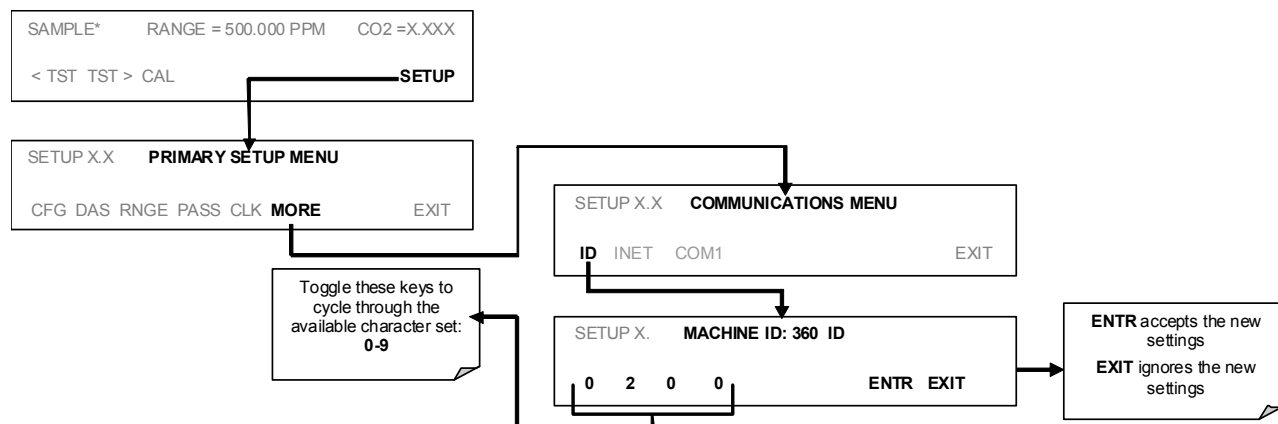

The ID number is only important if more than one analyzer is connected to the same communications channel (e.g., a multi-drop setup). Different models of

Teledyne Instruments analyzers have different default ID numbers, but if two analyzers of the same model type are used on one channel (for example, two T360's), the ID of one instrument needs to be changed.

The ID can also be used for to identify any one of several analyzers attached to the same network but situated in different physical locations.

4.11.2. COM Port Default Settings

Received from the factory, the analyzer is set up to emulate a DCE or modem, with pin 3 of the DB-9 connector designated for receiving data and pin 2 designated for sending data.

- **COM1:** RS-232 (fixed) DB-9 male connector.
 - **Baud rate:** 115200 bits per second (baud).
 - **Data Bits:** 8 data bits with 1 stop bit.
 - **Parity:** None.
- **COM2:** RS-232 (configurable), DB-9 female connector.
 - **Baud rate:** 19200 bits per second (baud).
 - **Data Bits:** 8 data bits with 1 stop bit.
 - **Parity:** None.

NOTE

Cables that appear to be compatible because of matching connectors may incorporate internal wiring that make the link inoperable. Check cables acquired from sources other than Teledyne Instruments for pin assignments before using.

In its default configuration, the T360 analyzer has two available RS-232 Com ports accessible via 2 DB-9 connectors on the back panel of the instrument. The COM1 connector is a male DB-9 connector and the COM2 is a female DB9 connector.

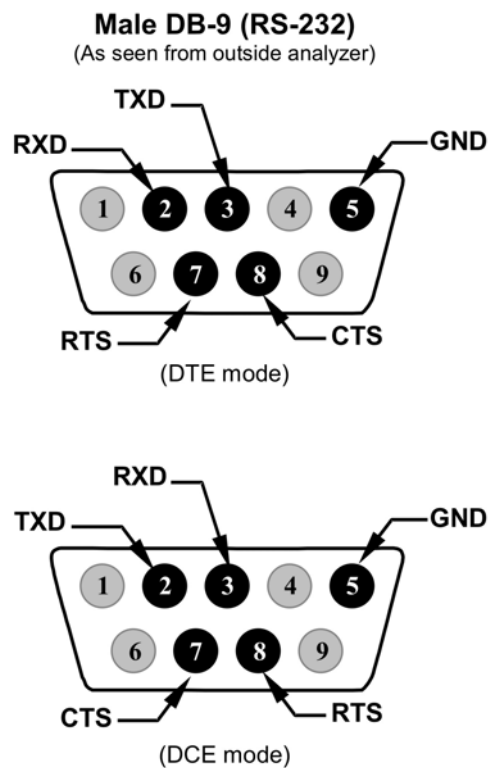

Figure 4-7: Rear Panel Connector Pin-Outs for COM1 & COM2 in RS-232 Mode

The signals from these two connectors are routed from the motherboard via a wiring harness to two 10-pin connectors on the CPU card, J11 and J12.

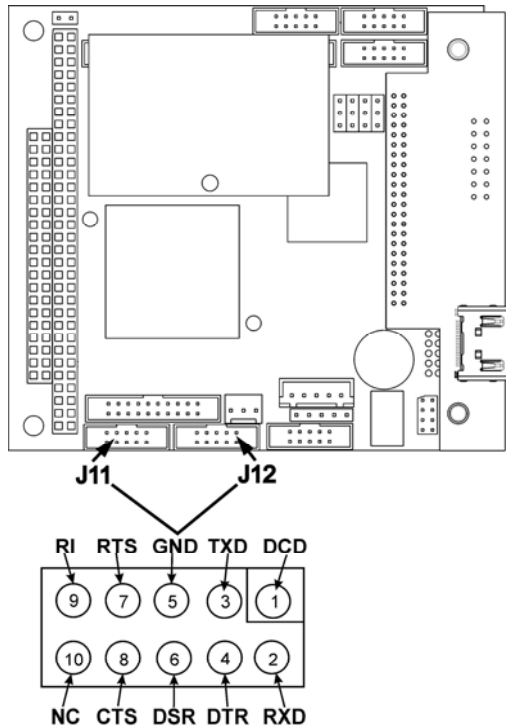

Figure 4-8: CPU Connector Pin-Outs for COM1 & COM2 in RS-232 Mode

Teledyne Instruments offers two mating cables, one of which should be applicable for your use.

- Part number WR000077, a DB-9 female to DB-9 female cable, 6 feet long. Allows connection of COM1 with the serial port of most personal computers. Also available as Option 60.
- Part number WR000024, a DB-9 female to DB-25 male cable. Allows connection to the most common styles of modems (e.g. Hayes-compatible) and code activated switches.

Both cables are configured with straight-through wiring and should require no additional adapters.

To assist in properly connecting the serial ports to either a computer or a modem, there are activity indicators just above the RS-232 port. Once a cable is connected between the analyzer and a computer or modem, both the red and green LEDs should be on. If the lights for COM 1 are not lit, use small switch on the rear panel (Figure 3-4) to switch it between DTE and DCE modes (see Section 4.11.4). If both LEDs are still not illuminated, check the cable for proper wiring.

4.11.3. RS-485 Configuration of COM2

As delivered from the factory, COM2 is configured for RS-232 communications. To configure this port for RS-485 communication, please contact the factory. If COM2 is configured for RS-485, the USB com port is no longer enabled.

4.11.4. DTE and DCE Communication

RS-232 was developed for allowing communications between data terminal equipment (DTE) and data communication equipment (DCE). Basic terminals always fall into the DTE category whereas modems are always considered DCE devices. The difference between the two is the pin assignment of the Data Receive and Data Transmit functions. DTE devices receive data on pin 2 and transmit data on pin 3; DCE devices receive data on pin 3 and transmit data on pin 2.

To allow the analyzer to be used with terminals (DTE), modems (DCE) and computers (which can be either), a switch mounted below the serial ports on the rear panel allows the user to switch between the two functions.

4.11.5. COM Port Communication Modes

Each of the analyzer's serial ports can be configured to operate in a number of different modes, listed in Table 4-9 which can be combined by adding the mode ID numbers. For example, quiet mode, computer mode and internet-enabled mode would carry a combined mode ID of 11, the standard configuration on the T360 **COM2** port. Note that each COM port needs to be configured independently.

Table 4-9: Com Port Communication Modes

MODE ¹	ID	DESCRIPTION
QUIET	1	Quiet mode suppresses any feedback from the analyzer (DAS reports, and warning messages) to the remote device and is typically used when the port is communicating with a computer program such as APICOM. Such feedback is still available but a command must be issued to receive them.
COMPUTER	2	Computer mode inhibits echoing of typed characters and is used when the port is communicating with a computer program, such as APICOM.
SECURITY	4	When enabled, the serial port requires a password before it will respond. The only command that is active is the help screen (? CR).
HESSEN PROTOCOL	16	The Hessen communications protocol is used in some European countries. Teledyne API's part number 02252 contains more information on this protocol.
E, 7, 1	2048	When turned on this mode switches the com port settings from No parity; 8 data bits; 1 stop bit to Even parity; 7 data bits; 1 stop bit
RS-485	1024	Configures the COM2 Port for RS-485 communication. RS-485 mode has precedence over multidrop mode if both are enabled.
MULTIDROP PROTOCOL	32	Multidrop protocol allows a multi-instrument configuration on a single communications channel. Multidrop requires the use of instrument IDs.
ENABLE MODEM	64	Enables to send a modem initialization string at power-up. Asserts certain lines in the RS-232 port to enable the modem to communicate.
ERROR CHECKING ²	128	Fixes certain types of parity errors at certain Hessen protocol installations.
XON/XOFF HANDSHAKE ²	256	Disables XON/XOFF data flow control also known as software handshaking.
HARDWARE HANDSHAKE	8	Enables CTS/RTS style hardwired transmission handshaking. This style of data transmission handshaking is commonly used with modems or terminal emulation protocols as well as by Teledyne API's APICOM software.
HARDWARE FIFO ²	512	Improves data transfer rate when on of the com ports.
COMMAND PROMPT	4096	Enables a command prompt when in terminal mode.

¹ Modes are accessed through the **SETUP → MORE → COM → COM[1 OR 2] → MODE** menu.

² The default setting for this feature is **ON**. Do not disable unless instructed to by Teledyne API's Technical Support personnel.

Press the following touchscreen buttons to select a communication mode for one of the com Ports, such as the following example where **HESSEN PROTOCOL** mode is enabled:

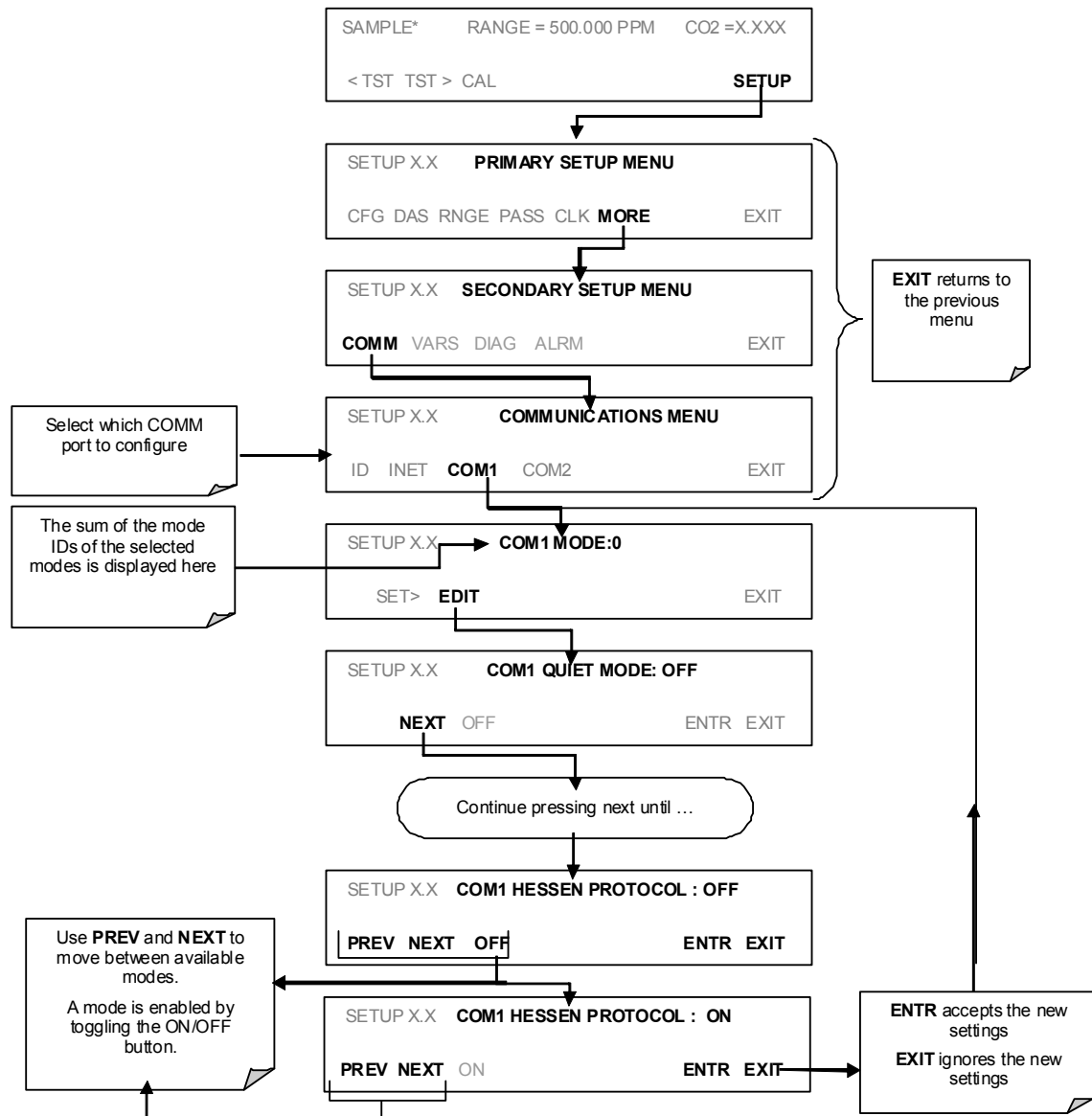

4.11.6. Remote Access via the Ethernet

When using the Ethernet interface, the analyzer can be connected to any standard 10BaseT or 100Base T Ethernet network via low-cost network hubs, switches or routers. The interface operates as a standard TCP/IP device on a user selectable port, which otherwise defaults to port 3000. This allows a remote computer to connect through the internet to the analyzer using APICOM, terminal emulators or other programs.

The Ethernet connector has two LEDs that are on the connector itself, indicating its current operating status.

Table 4-10: Ethernet Status Indicators

LED	Function
amber (link)	On when connection to the LAN is valid.
green (activity)	Flickers during any activity on the LAN.

4.11.6.1. CONFIGURING THE ETHERNET INTERFACE USING DHCP

The Ethernet option for your analyzer uses Dynamic Host Configuration Protocol (DHCP) to automatically configure its interface with your LAN. This requires your network servers also be running DHCP. The analyzer will do this the first time you turn the instrument on after it has been physically connected to your network. Once the instrument is connected and turned on it will appear as an active device on your network without any extra set up steps or lengthy procedures.

Table 4-11: LAN/Internet Configuration Properties

PROPERTY	DEFAULT STATE	DESCRIPTION
DHCP	ON	This displays whether the DHCP is turned ON or OFF. Press EDIT and toggle ON for automatic configuration after first consulting network administrator. (
INSTRUMENT IP ADDRESS		This string of four packets of 1 to 3 numbers each (e.g. 192.168.76.55.) is the address of the analyzer itself.
GATEWAY IP ADDRESS	0.0.0.0	Can only be edited when DHCP is set to OFF. A string of numbers very similar to the Instrument IP address (e.g. 192.168.76.1.) that is the address of the computer used by your LA To access the Internet.
SUBNET MASK	0.0.0.0	Can only be edited when DHCP is set to OFF. Also a string of four packets of 1 to 3 numbers each (e.g. 255.255.252.0) that identifies the LA To which the device is connected. All addressable devices and computers on a LAN must have the same subnet mask. Any transmissions sent to devices with different subnets are assumed to be outside of the LAN and are routed through the gateway computer onto the Internet.
TCP PORT¹	3000	This number defines the terminal control port by which the instrument is addressed by terminal emulation software, such as Internet or Teledyne API's APICOM.
HOST NAME	T100	The name by which your analyzer will appear when addressed from other computers on the LAN or via the Internet. To change, see Section 4.11.6.3.
¹ Do not change the setting for this property unless instructed to by Teledyne API's Technical Support personnel.		

NOTE

It is recommended that you check these settings the first time you power up your analyzer after it has been physically connected to the LAN/Internet to make sure that the DHCP has successfully downloaded the appropriate information from you network server(s).

If the gateway IP, instrument IP and the subnet mask are all zeroes (e.g. "0.0.0.0"), the DCHP was not successful.

**You may have to manually configure the analyzer's Ethernet properties.
See your network administrator.**

To view the above properties, press:

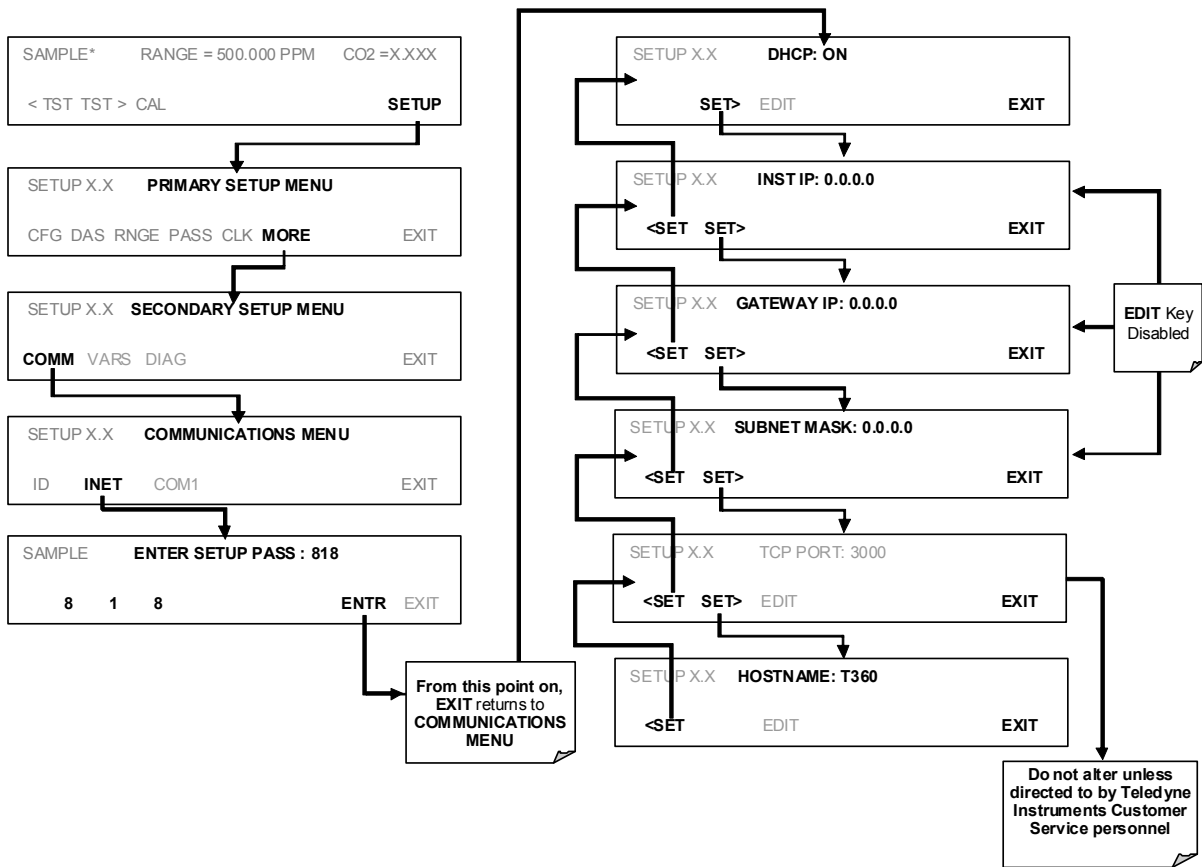

4.11.6.2. MANUALLY CONFIGURING THE ETHERNET (STATIC IP ADDRESS)

To configure Ethernet communication manually:

1. Connect a cable from the analyzer's Ethernet port to a Local Area Network (LAN) or Internet port.
2. From the analyzer's front panel touchscreen, access the Communications Menu as shown below, turning DHCP mode to OFF.

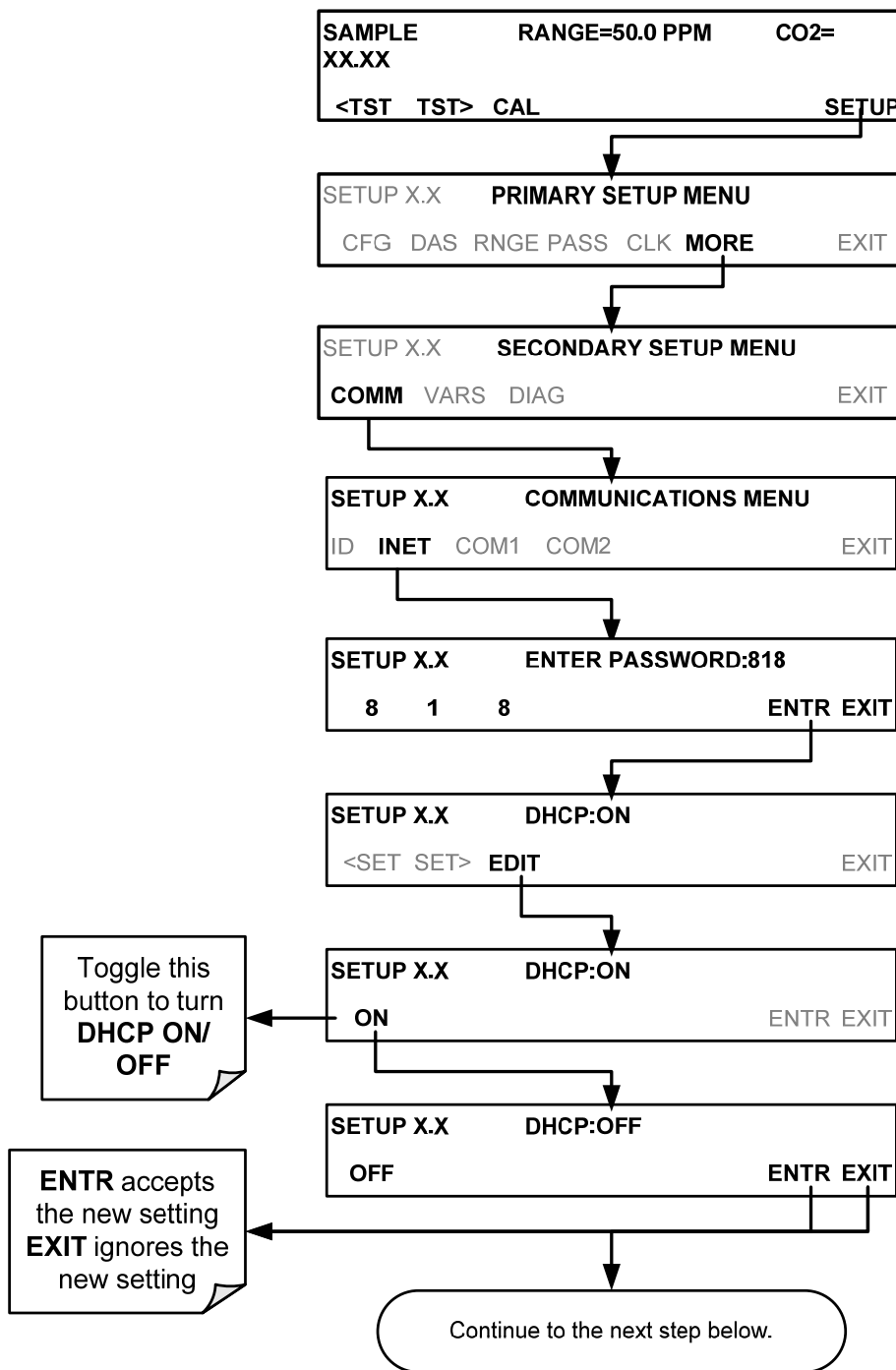

Next, refer to Table 4-11 for the default Ethernet configuration settings and configure the **INSTRUMENT IP** addresses by pressing:

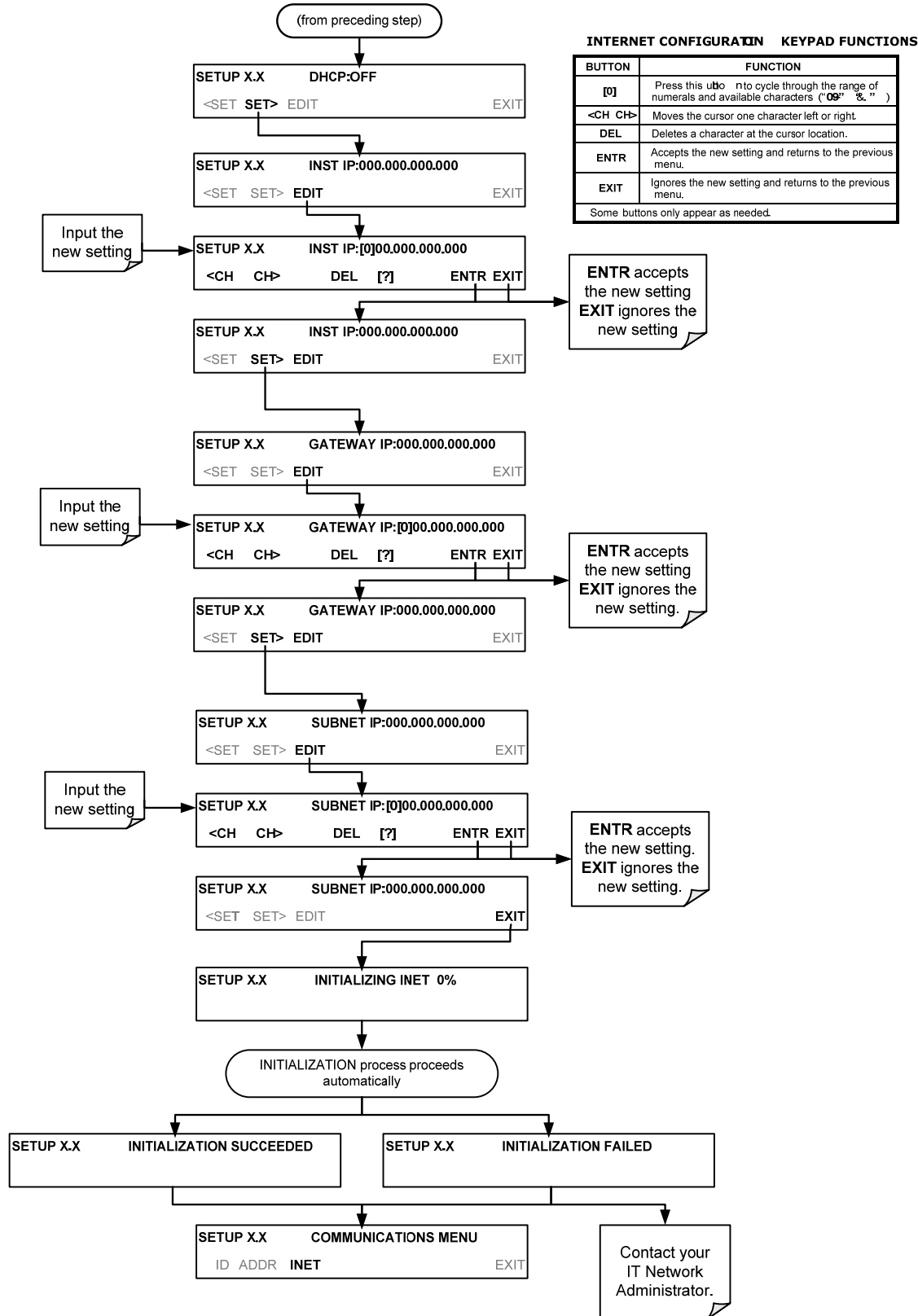

4.11.6.3. CHANGING THE ANALYZER'S HOSTNAME

The **HOSTNAME** is the name by which the analyzer appears on your network. The default name for all TAPI Model T360 analyzers is **T360**. To change this name (particularly if you have more than one Model T360 analyzer on your network), press.

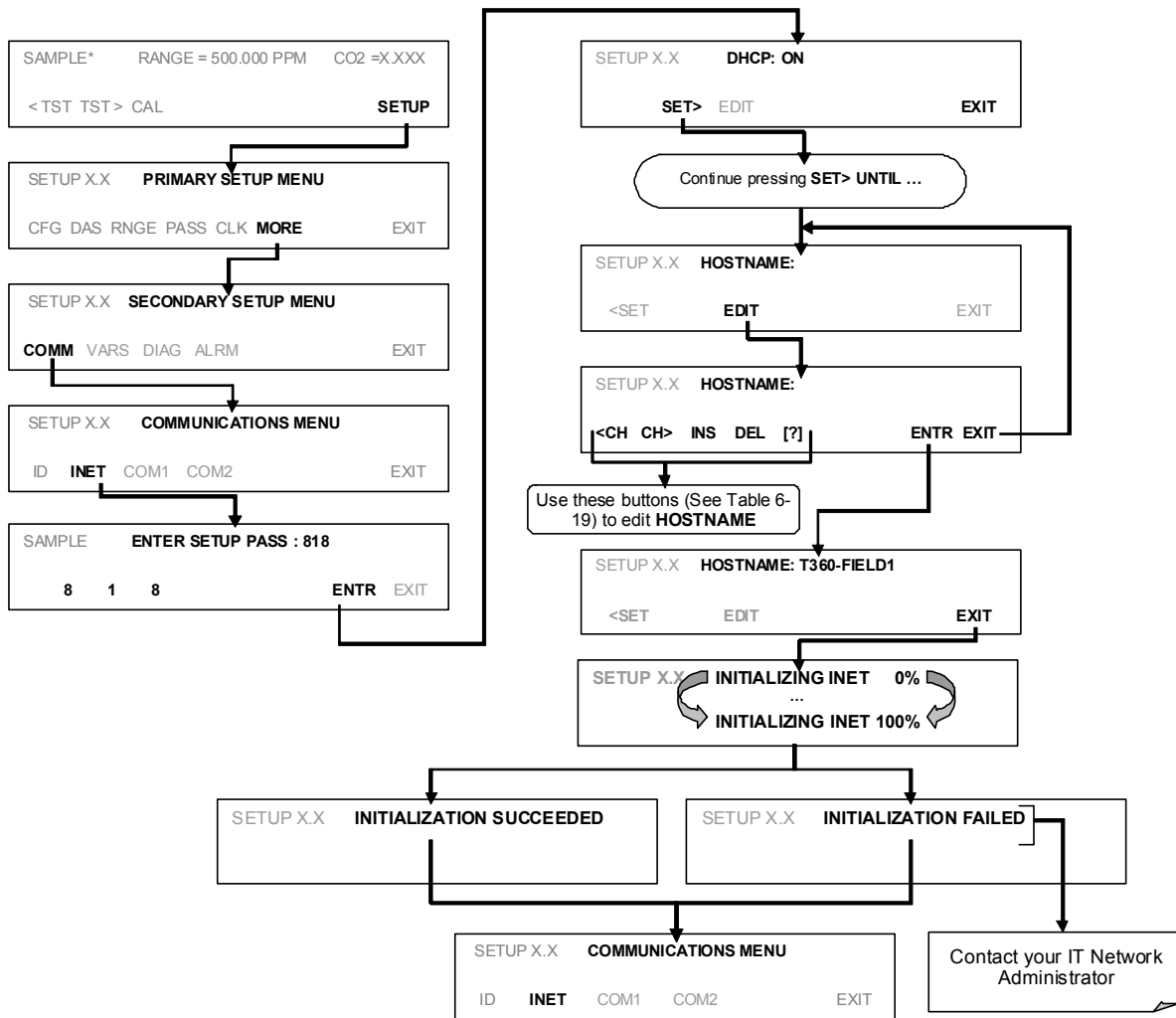

Table 4-12: Internet Configuration Touchscreen Functions

BUTTON	FUNCTION
<CH	Moves the cursor one character to the left.
CH>	Moves the cursor one character to the right.
INS	Inserts a character before the cursor location.
DEL	Deletes a character at the cursor location.
[?]	Press this button to cycle through the range of numerals and characters available for insertion. 0-9, A-Z, space ' ~ ! @ # \$ % ^ & * () - _ = + [] { } < > \ ; : , . / ?
ENTR	Accepts the new setting and returns to the previous menu.
EXIT	Ignores the new setting and returns to the previous menu.
Some buttons only appear as applicable.	

4.11.7. USB Port Setup

The analyzer can be operated through a personal computer by downloading the TAPI USB driver and directly connecting their respective USB ports.

1. Install the Teledyne T-Series USB driver on your computer, downloadable from the Teledyne API website under Help Center>Software Downloads (www.teledyne-api.com/software).
2. Run the installer file: "TAPIVCPInstaller.exe"

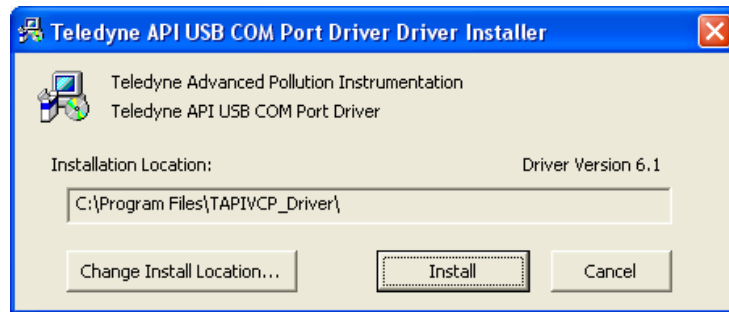

3. Connect the USB cable between the USB ports on your personal computer and your analyzer. The USB cable should be a Type A – Type B cable, commonly used as a USB printer cable.
4. Determine the Windows XP Com Port number that was automatically assigned to the USB connection. (Start → Control Panel → System → Hardware → Device Manager). This is the com port that should be set in the communications software, such as APIcom or Hyperterminal.

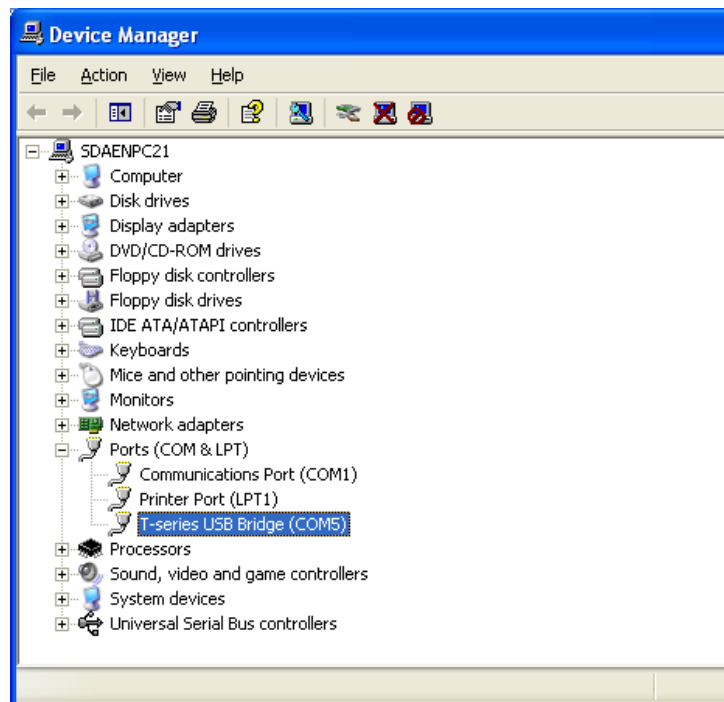

Refer to the Quick Start (*Direct Cable Connection*) section of the Teledyne APIcom Manual, PN 07463.

5. In the instrument's SETUP>MORE>COMM>COM2 menu, make the following settings:

Baud Rate: 115200
 COM2 Mode Settings:

Quiet Mode	ON
Computer Mode	ON
MODBUS RTU	OFF
MODBUS ASCII	OFF
E,8,1 MODE	OFF
E,7,1 MODE	OFF
RS-485 MODE	OFF
SECURITY MODE	OFF
MULTIDROP MODE	OFF
ENABLE MODEM	OFF
ERROR CHECKING	ON
XON/XOFF HANDSHAKE	OFF
HARDWARE HANDSHAKE	OFF
HARDWARE FIFO	ON
COMMAND PROMPT	OFF

6. Next, configure your communications software, such as APIcom. Use the COM port determined in Step 4 and the baud rate set in Step 5. The figures below show how these parameters would be configured in the Instrument Properties window in APIcom when configuring a new instrument. See the APIcom manual (PN 07463) for more details.

Note that USB configuration requires that baud rate (Section 4.11.10) of instrument and PC match. Also, using the USB port disallows use of the rear panel COM2 port except for multidrop communications (Section 4.11.8).

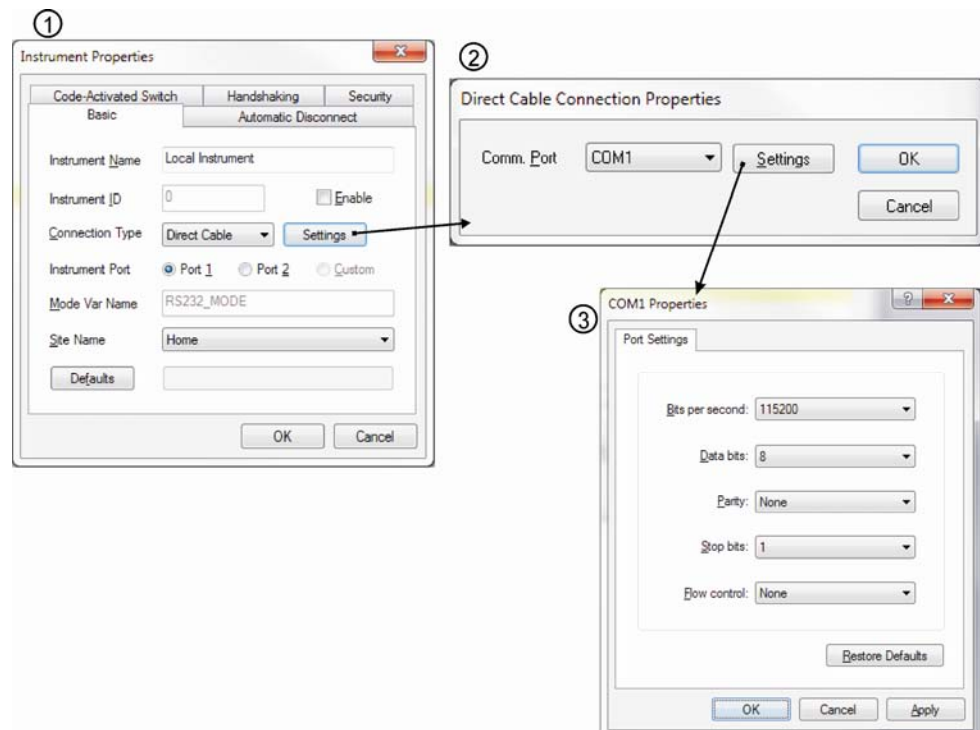

4.11.8. Multidrop RS-232 Setup

When the RS-232 Multidrop option is installed, connection adjustments and configuration through the menu system are required. This section provides instructions for the internal connection adjustments, then for external connections, and ends with instructions for menu-driven configuration.

Note that because the RS-232 Multidrop option uses both the **RS232** and **COM2** DB9 connectors on the analyzer's rear panel to connect the chain of instruments, **COM2** port is no longer available for separate RS-232 or RS-485 operation.



CAUTION – Risk of Instrument Damage and Warranty Invalidation

Printed circuit assemblies (PCAs) are sensitive to electro-static discharges too small to be felt by the human nervous system. Damage resulting from failure to use ESD protection when working with electronic assemblies will void the instrument warranty. See *A Primer on Electro-Static Discharge* section in this manual for more information on preventing ESD damage.

In each instrument with the Multidrop option there is a shunt jumpering two pins on the serial Multidrop and LVDS printed circuit assembly (PCA), as shown in Figure 4-9. This shunt must be removed from all instruments except that designated as last in the multidrop chain, which must remain terminated. This requires powering off and opening each instrument and making the following adjustments:

1. With **NO power** to the instrument, remove its top cover and lay the rear panel open for access to the multidrop PCA, which is seated on the CPU.
2. On the Multidrop/LVDS PCA's JP2 connector, remove the shunt that jumpers Pins
21 ↔ 22 as indicated in Figure 4-9. (Do this for all but the last instrument in the chain where the shunt should remain at Pins 21 ↔ 22).
3. Check that the following cable connections are made in *all* instruments (again refer to Figure 4-9).
 - J3 on the Multidrop/LVDS PCA to the CPU's COM1 connector
(Note that the CPU's COM2 connector is not used in Multidrop)
 - J4 on the Multidrop/LVDS PCA to J12 on the motherboard
 - J1 on the Multidrop/LVDS PCS to the front panel LCD

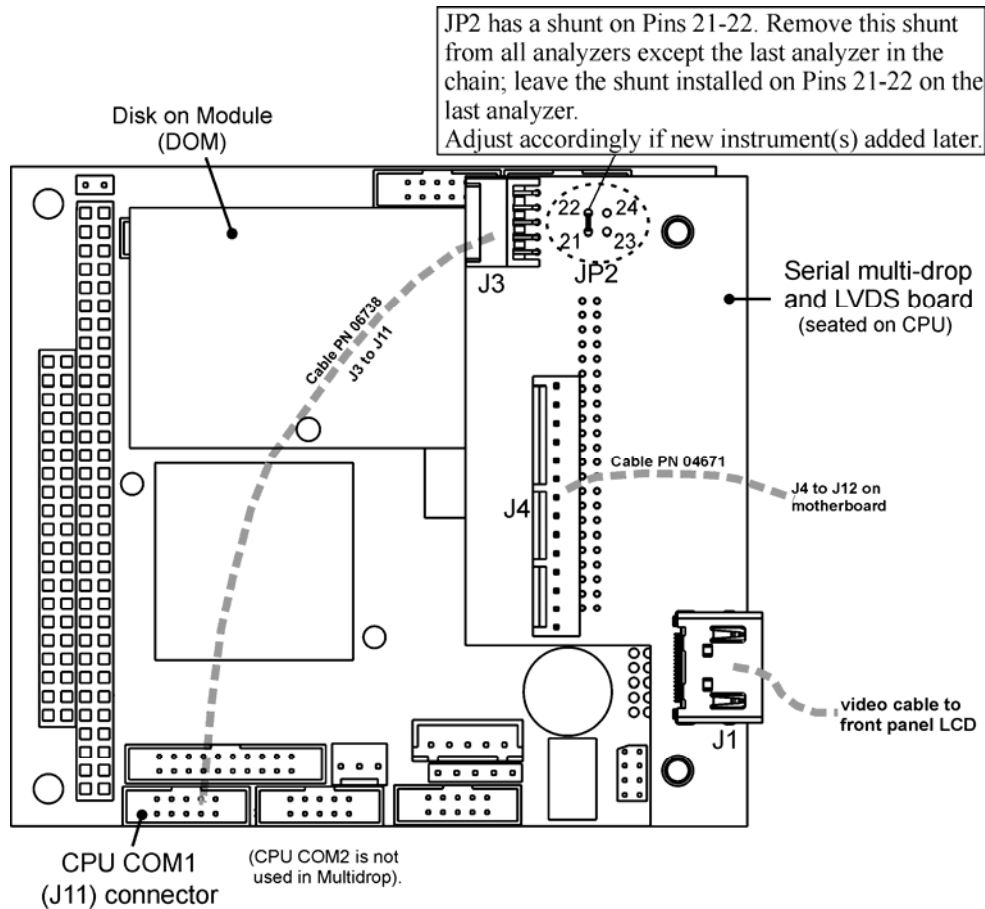

Figure 4-9: Jumper and Cables for Multidrop Mode

Note: If you are adding an instrument to the end of a previously configured chain, remove the shunt between Pins 21 ↔ 22 of the Multidrop PCA in the instrument that was previously the last instrument in the chain.

4. Close the instrument.
5. Referring to Figure 4-10, use straight-through DB9 male-DB9 female cables to interconnect the host RS232 port to the first analyzer's RS232 port; then from the first analyzer's COM2 port to the second analyzer's RS232 port; from the second analyzer's COM2 port to the third analyzer's RS232 port, etc., connecting in this fashion up to eight analyzers, subject to the distance limitations of the RS-232 standard.
6. On the rear panel of each analyzer, adjust the DCE DTE switch so that the green and the red LEDs (RX and TX) of the COM1 connector (labeled RS232) are both lit. (Ensure you are using the correct RS-232 cables that are internally wired specifically for RS232 communication).

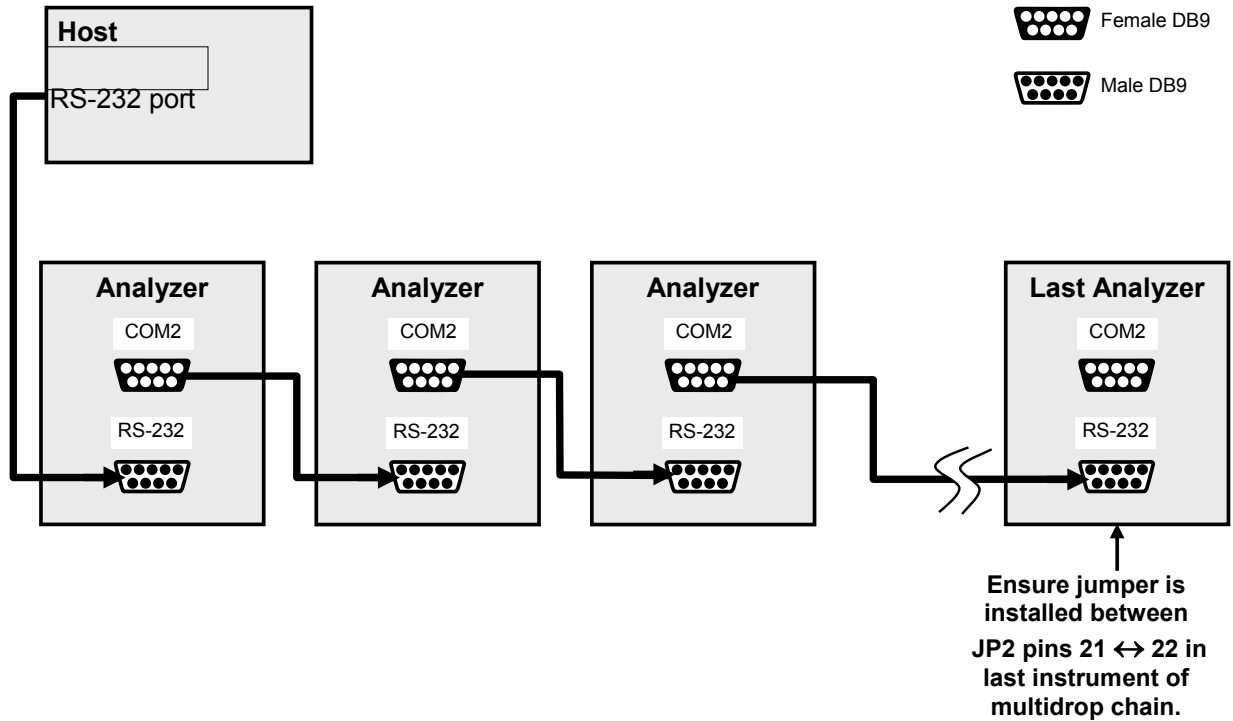

Figure 4-10: RS-232-Multidrop Host-to-Analyzer Interconnect Diagram

7. BEFORE communicating from the host, power on the instruments and check that the Machine ID (Section 4.11.1) is unique for each. On the front panel menu, use `SETUP>MORE>COMM>ID`. The default ID is typically the model number or "0"; to change the 4-digit identification number, press the button below the digit to be changed; once changed, press/select `ENTER` to accept the new ID for that instrument.
8. Next, in the `SETUP>MORE>COMM>COM1` menu (do not use the `COM2` menu for multidrop), edit the `COM1 MODE` parameter as follows: press/select `EDIT` and set only `QUIET MODE`, `COMPUTER MODE`, and `MULTIDROP MODE` to `ON`. Do not change any other settings.
9. Press/select `ENTER` to accept the changed settings, and ensure that `COM1 MODE` now shows 35.
10. Press/select `SET>` to go to the `COM1 BAUD RATE` menu and ensure it reads the same for all instruments (edit as needed so that all instruments are set at the same baud rate).

NOTES:

- The (communication) Host instrument can address only one instrument at a time, each by its unique ID (see Step 7 above).
- Teledyne API recommends setting up the first link, between the Host and the first analyzer, and testing it before setting up the rest of the chain.

4.11.9. MODBUS Setup

The following set of instructions assumes that the user is familiar with MODBUS communications, and provides minimal information to get started. For additional instruction, please refer to the Teledyne API MODBUS manual, PN 06276. Also refer to www.modbus.org for MODBUS communication protocols.

1.1.1.1.1 Minimum Requirements

- Instrument firmware with MODBUS capabilities installed.
- MODBUS-compatible software (TAPI uses MODBUS Poll for testing; see www.modbustools.com)
- Personal computer
- Communications cable (Ethernet or USB or RS232)
- Possibly a null modem adapter or cable

1.1.1.1.2 Actions

Set Com Mode parameters Comm	<p>Ethernet: Using the front panel menu, go to SETUP – MORE – COMM – INET; scroll through the INET submenu until you reach TCP PORT 2 (the standard setting is 502), then continue to TCP PORT 2 MODBUS TCP/IP; press EDIT and toggle the menu button to change the setting to ON, then press ENTR. (Change Machine ID if needed: see “Slave ID”).</p> <p>USB/RS232: Using the front panel menu, go to SETUP – MORE – COMM – COM2 – EDIT; scroll through the COM2 EDIT submenu until the display shows COM2 MODBUS RTU: OFF (press OFF to change the setting to ON. Scroll NEXT to COM2 MODBUS ASCII and ensure it is set to OFF. Press ENTR to keep the new settings. (If RTU is not available with your communications equipment, set the COM2 MODBUS ASCII setting to ON and ensure that COM2 MODBUS RTU is set to OFF. Press ENTR to keep the new settings).</p>
Slave ID	If your analyzer is connected to a network with at least one other analyzer of the same model, a unique Slave ID must be assigned to each. Using the front panel menu, go to SETUP – MORE – COMM – ID. The MACHINE ID default is either “0” or the same as the model number. Toggle the menu buttons to change the ID.
Reboot analyzer	For the settings to take effect, power down the analyzer, wait 5 seconds, and power up the analyzer.
Make appropriate cable connections	<p>Connect your analyzer either:</p> <ul style="list-style-type: none"> • via its Ethernet or USB port to a PC (this may require a USB-to-RS232 adapter for your PC; if so, also install the software driver from the CD supplied with the adapter, and reboot the computer if required), or • via its COM2 port to a null modem (this may require a null modem adapter or cable).
Specify MODBUS software settings (examples used here are for MODBUS Poll software)	<ol style="list-style-type: none"> 1. Click Setup / [Read / Write Definition] /. <ol style="list-style-type: none"> a. In the Read/Write Definition window (see example that follows) select a Function (what you wish to read from the analyzer). b. Input Quantity (based on your firmware’s register map). c. In the View section of the Read/Write Definition window select a Display (typically Float Inverse). d. Click OK. 2. Next, click Connection/Connect. <ol style="list-style-type: none"> a. In the Connection Setup window (see example that follows), select the options based on your computer. b. Press OK.
Read the Modbus Poll Register	Use the Register Map to find the test parameter names for the values displayed (see example that follows) If desired, assign an alias for each.

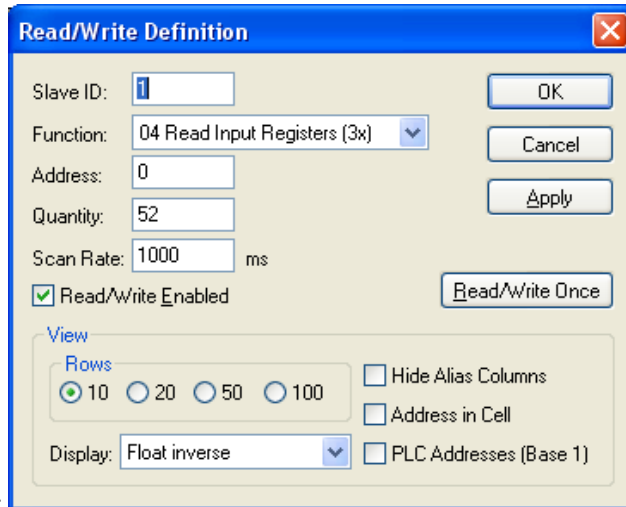

Example Read/Write Definition window:

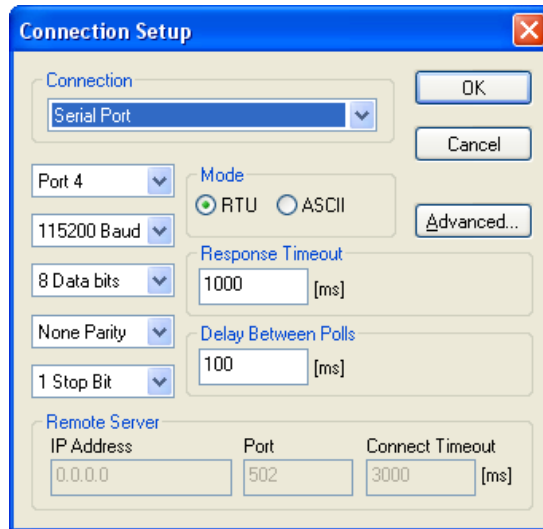

Example Connection Setup window:

Example MODBUS Poll window:

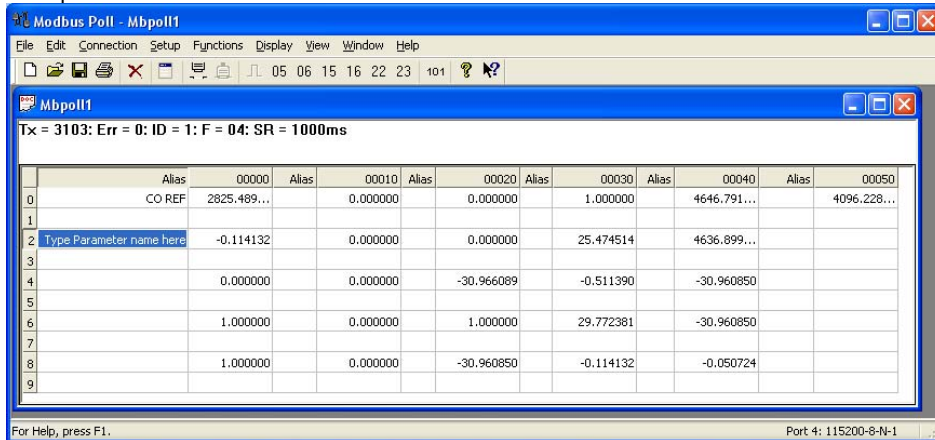

4.11.10. COM Port Baud Rate

To select the baud rate of one of the COM Ports, press:

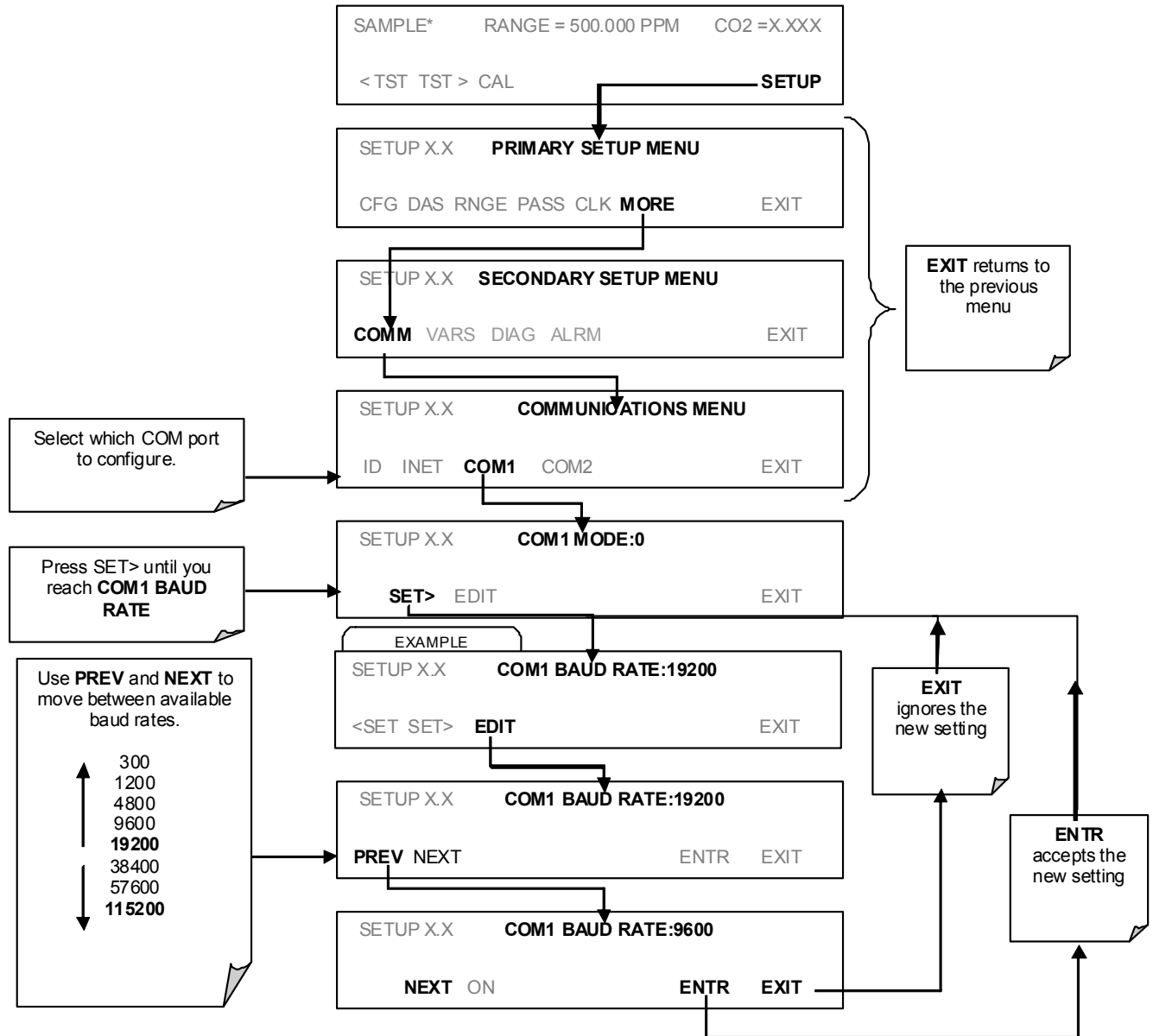

4.11.11. COM Port Testing

The serial ports can be tested for correct connection and output in the com menu. This test sends a string of 256 'w' characters to the selected COM port. While the test is running, the red LED on the rear panel of the analyzer should flicker.

To initiate the test press the following touchscreen button sequence.

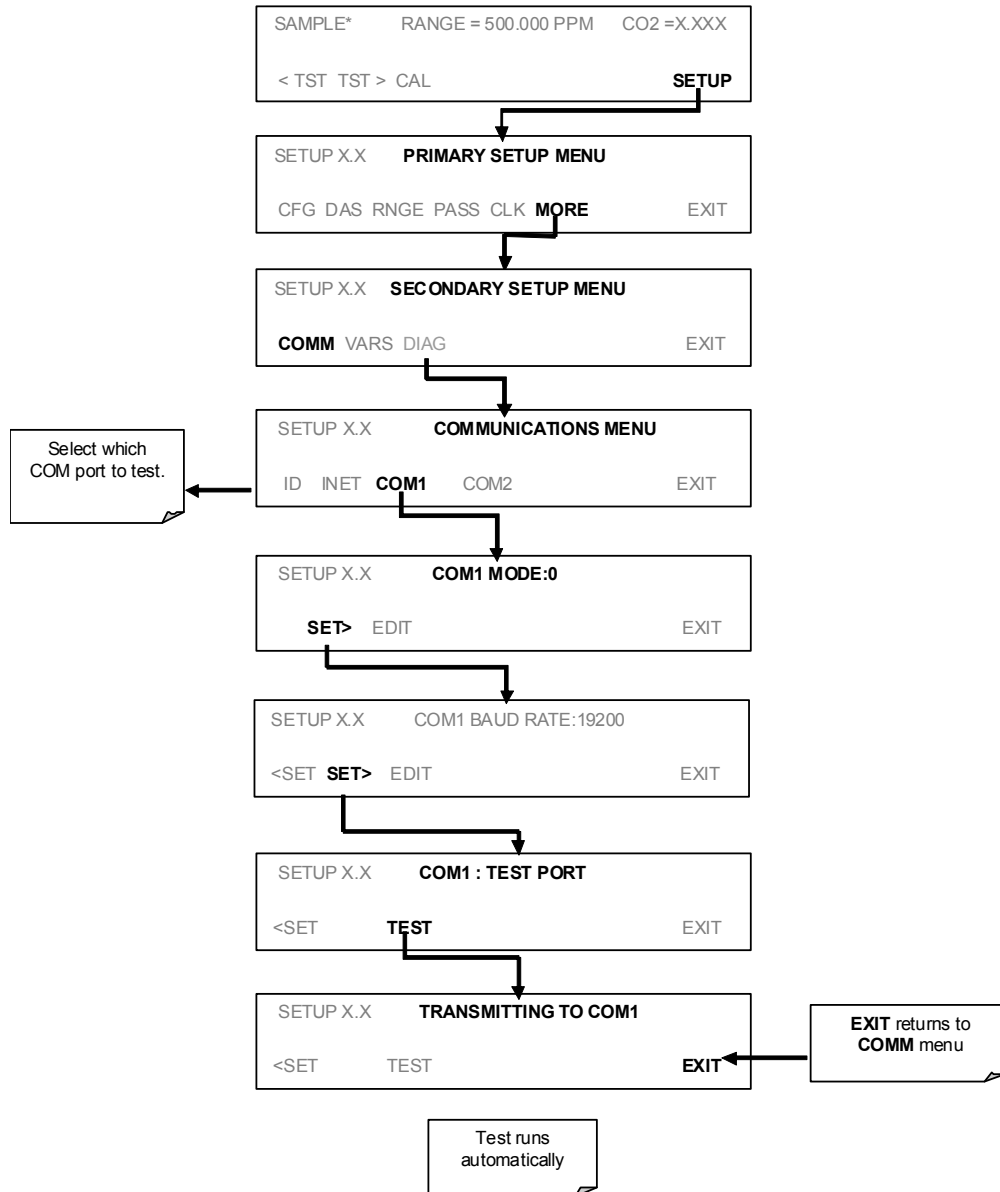

4.12. SETUP → MORE → VARS: INTERNAL VARIABLES (VARS)

The T360 has several-user adjustable software variables, which define certain operational parameters. Usually, these variables are automatically set by the instrument's firmware, but can be manually re-defined using the VARS menu. Table 4-13 lists all variables that are available within the 818 password protected level.

Table 4-13: Variable Names (VARS)

NO.	VARIABLE	DESCRIPTION	ALLOWED VALUES
0	DAS_HOLD_OFF	Changes the internal data acquisition system (DAS) hold-off time, which is the duration when data are not stored in the DAS because the software considers the data to be questionable. That is the case during warm-up or just after the instrument returns from one of its calibration modes to SAMPLE mode. DAS_HOLD_OFF can be disabled entirely in each DAS channel.	Can be between 0.5 and 20 minutes Default=15 min.
1	CONC_PRECISION	Allows the user to set the number of significant digits to the right of the decimal point display of concentration and stability values.	AUTO, 1, 2, 3, 4 Default=AUTO
2	STABIL_GAS	Selects which gas measurement is displayed when the STABIL test function is selected.	CO ₂ & O ₂ ¹
3	DYN_ZERO	Dynamic zero automatically adjusts offset and slope of the CO ₂ response when performing a zero point calibration during an AutoCal (Section 5).	ON/OFF
4	DYN_SPAN	Dynamic span automatically adjusts slope and slope of the CO ₂ response when performing a zero point calibration during an AutoCal (Section 5). Note that the DYN_ZERO and DYN_SPAN features are not allowed for applications requiring EPA equivalency.	ON/OFF
5	CLOCK_ADJ	Adjusts the speed of the analyzer's clock. Choose the + sign if the clock is too slow, choose the - sign if the clock is too fast.	-60 to +60 s/day
7	SERVICE_CLEAR	ON resets the service interval timer.	ON/OFF
7	TIME_SINCE_SVC	Time since last service (hours).	0–500000
7	SVC_INTERVAL	Sets the interval between service reminders (hours).	0–100000

¹ O₂ gas measurement is only available in analyzers with O₂ sensor options installed.

To access and navigate the VARS menu, use the following touchscreen button sequence:

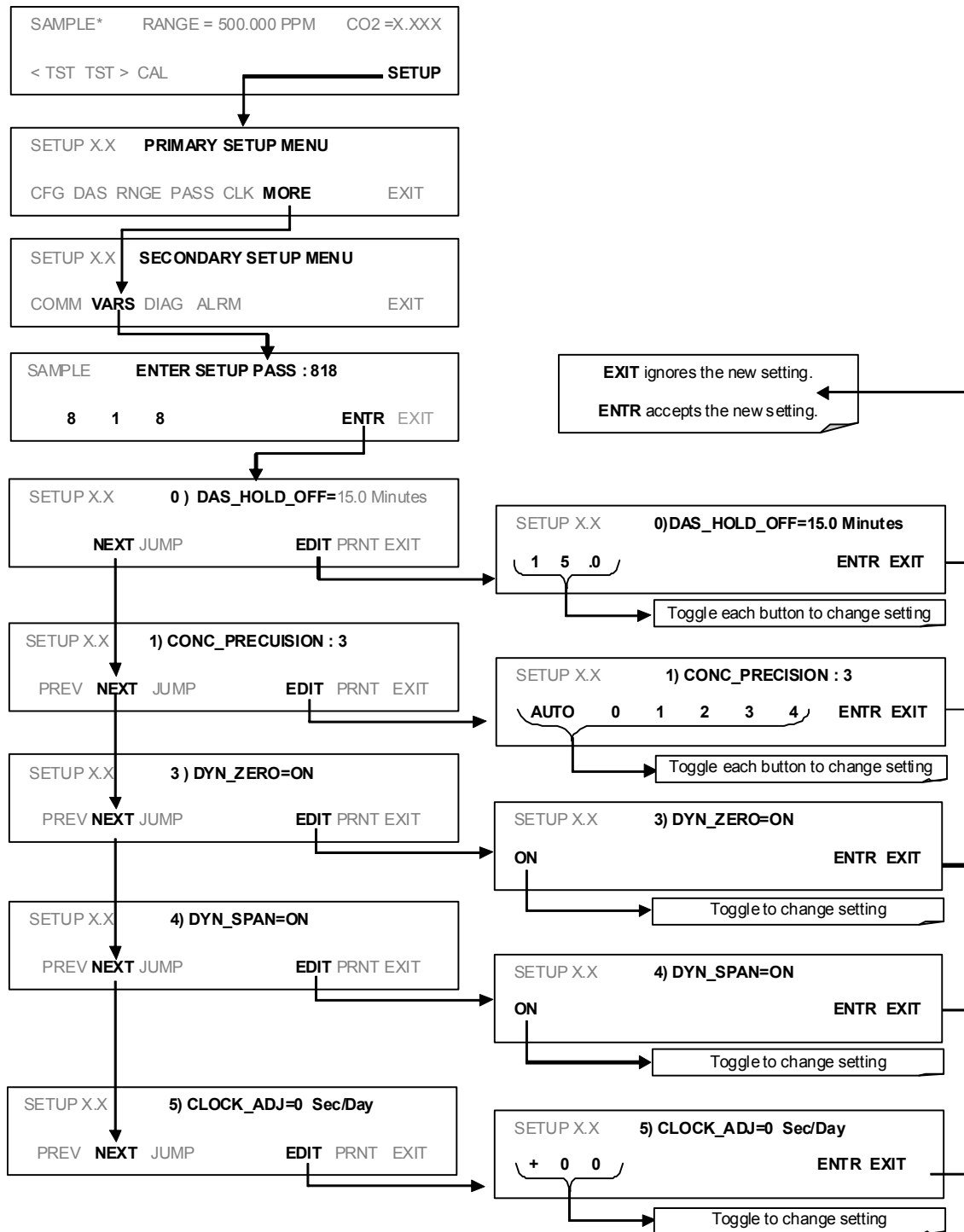

4.13. SETUP → MORE → DIAG: USING THE DIAGNOSTICS FUNCTIONS

A series of diagnostic tools is grouped together under the **SETUP→MORE→DIAG** menu. As these parameters are dependent on firmware revision (see Menu Tree A-6 in Appendix A). The individual parameters, however, are explained in more detail in the indicated in 6-15. These tools can be used in a variety of troubleshooting and diagnostic procedures and are referred to in many places of the maintenance and trouble-shooting s.

Table 4-14: T360 Diagnostic (DIAG) Functions

DIAGNOSTIC FUNCTION AND MEANING	Front Panel Mode Indicator	SECTION
SIGNAL I/O: Allows observation of all digital and analog signals in the instrument. Allows certain digital signals such as valves and heaters to be toggled ON and OFF.	DIAG I/O	4.13.2
ANALOG OUTPUT: When entered, the analyzer performs an analog output step test. This can be used to calibrate a chart recorder or to test the analog output accuracy.	DIAG AOUT	4.13.3
ANALOG I/O CONFIGURATION: the signal levels of the instruments analog outputs may be calibrated (either individually or as a group). Various electronic parameters such as signal span, and offset are available for viewing and configuration.	DIAG AIO	4.13.4
ELECTRIC TEST: The analyzer is performing an electric test. This test simulates IR detector signal in a known manner so that the proper functioning of the sync/demod board can be verified.	DIAG OPTIC	4.13.5
DARK CALIBRATION: The analyzer is performing a dark calibration procedure. This procedure measures and stores the inherent dc offset of the sync/demod board electronics.	DIAG ELEC	4.13.6
PRESSURE CALIBRATION: The analyzer records the current output of the sample gas pressure sensor. This value is used by the CPU to compensate the CO ₂ concentration.	DIAG PCAL	4.13.7
FLOW CALIBRATION: This function is used to calibrate the gas flow output signal. This setting is retained when exiting DIAG .	DIAG FCAL	4.13.8
TEST CHAN OUTPUT: Configures the A4 analog output channel.	DIAG TCHN	4.13.9

4.13.1. Accessing the Diagnostic Features

To access the **DIAG** functions press the following buttons:

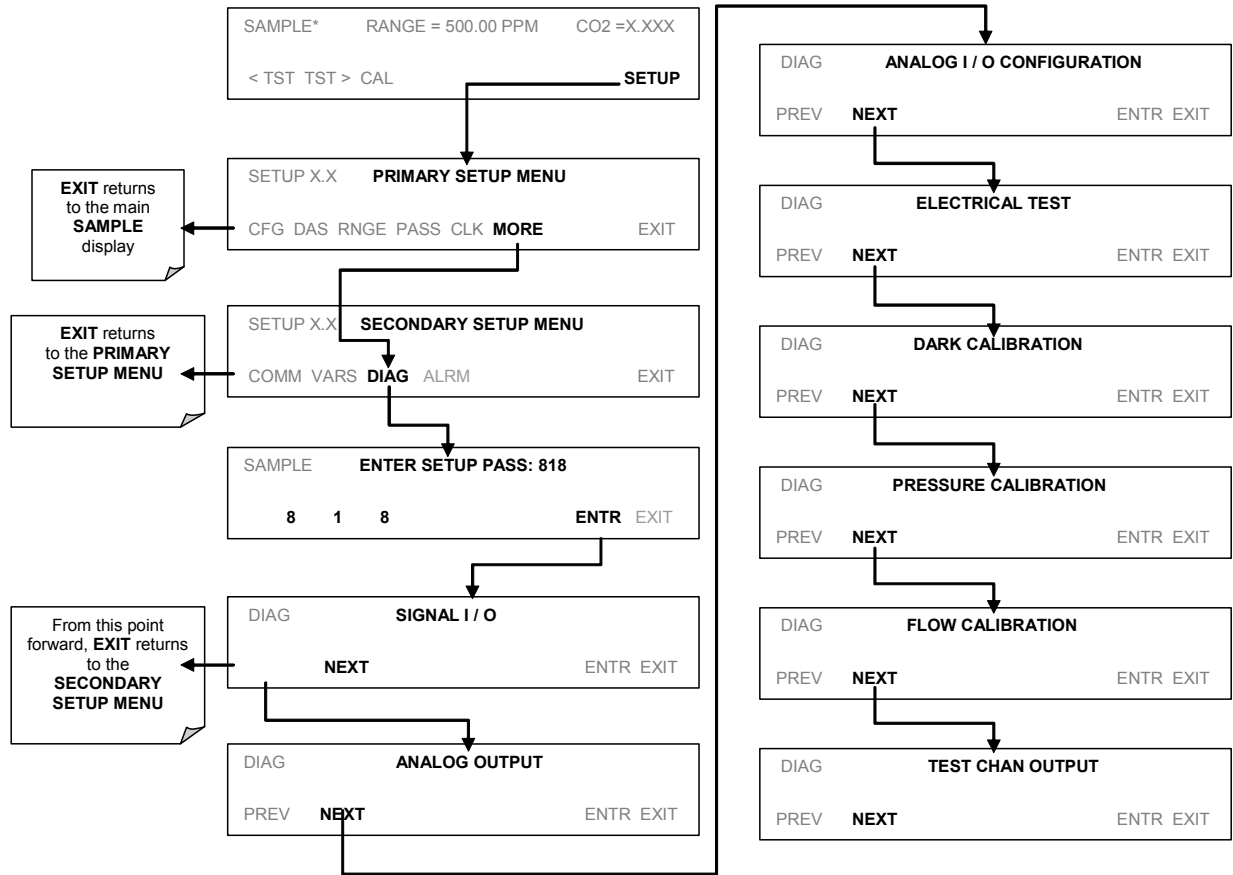

4.13.2. Signal I/O

The signal I/O diagnostic mode allows reviewing and changing the digital and analog input/output functions of the analyzer. See Appendix A-4 for a complete list of the parameters available for review under this menu.

NOTE

Any changes of signal I/O settings will remain in effect only until the signal I/O menu is exited. Exceptions are the ozone generator override and the flow sensor calibration, which remain as entered when exiting.

To enter the signal I/O test mode, press:

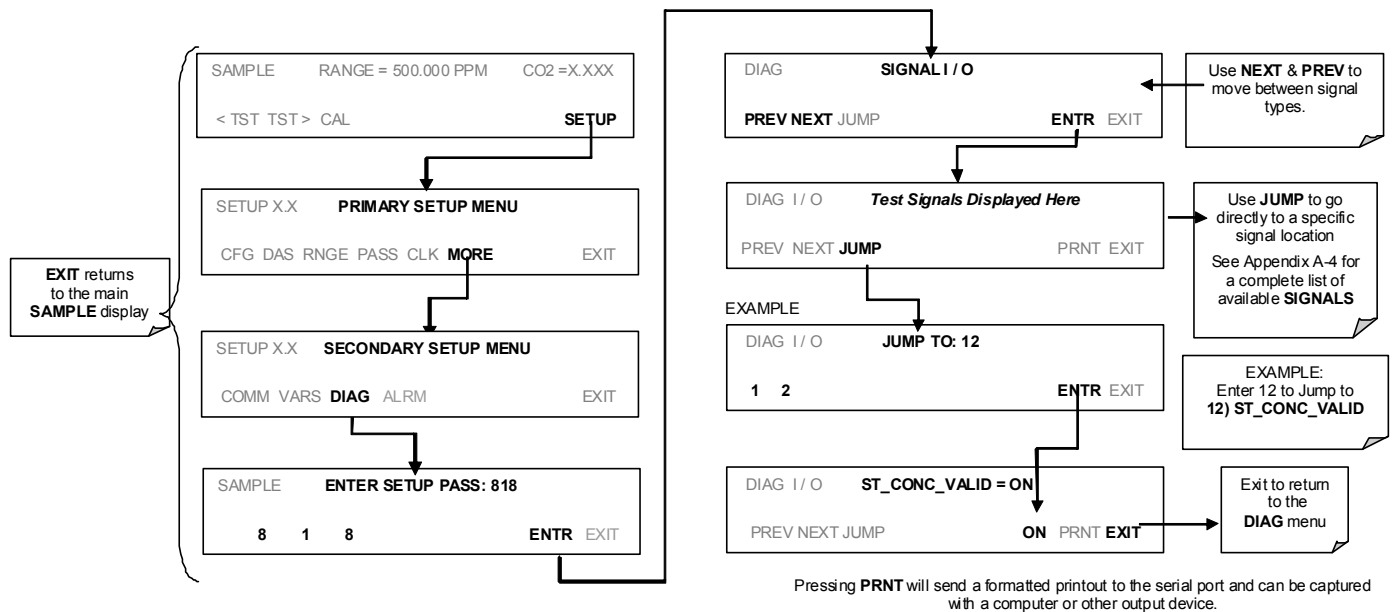

4.13.3. Analog Output Step Test

This test can be used to check the accuracy and proper operation of the analog outputs. The test forces all four analog output channels to produce signals ranging from 0% to 100% of the full scale range in 20% increments. This test is useful to verify the operation of the data logging/recording devices attached to the analyzer.

To begin the Analog Output Step Test press:

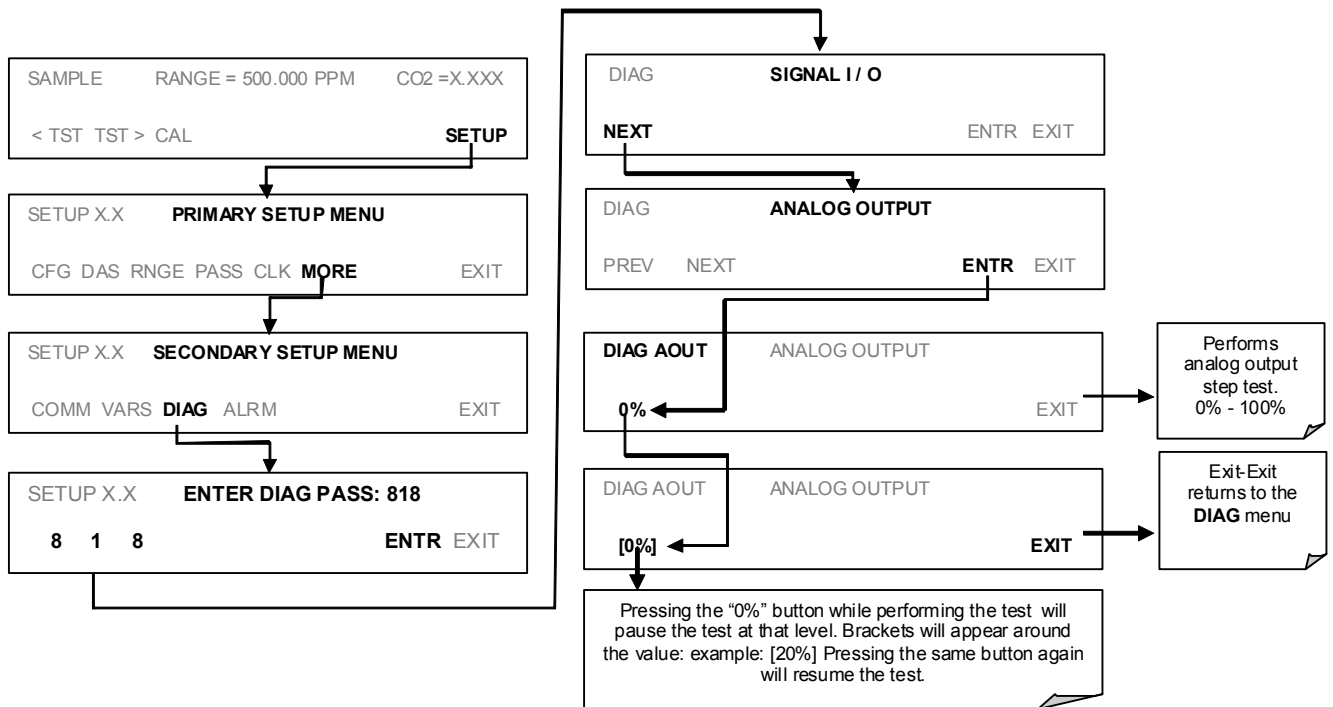

4.13.4. Analog I/O Configuration

The analog I/O functions that are available in the T360 are:

Table 4-15: DIAG - Analog I/O Functions

Sub Menu	Function
AOUTS CALIBRATED:	Shows the status of the analog output calibration (YES/NO) and initiates a calibration of all analog output channels.
CONC_OUT_1	Sets the basic electronic configuration of the A1 analog output (CO ₂). There are three options: Range: Selects the signal type (voltage or current loop) and full scale level of the output. REC_OFS: Allows setting a voltage offset (not available when RANGE is set to CURRENT loop). Auto_CAL: Performs the same calibration as AOUT CALIBRATED, but on this one channel only. NOTE: Any change to RANGE or REC_OFS requires recalibration of this output.
CONC_OUT_2	Same as for CONC_OUT_1 but for analog channel 2 (CO ₂)
TEST OUTPUT	Same as for CONC_OUT_1 but for analog channel 4 (TEST)
AIN CALIBRATED	Shows the calibration status (YES/NO) and initiates a calibration of the analog to digital converter circuit on the motherboard.
XIN1 . . . XIN8	For each of 8 external analog input channels, shows the gain, offset, engineering units, and whether the channel is to show up as a Test function.

To configure the analyzer's three analog outputs, set the electronic signal type of each channel and calibrate the outputs. This consists of:

- Selecting an output type (voltage or current, if an optional current output driver has been installed) and the signal level that matches the input requirements of the recording device attached to the channel, see Section 4.13.4.1.
- Calibrating the output channel. This can be done automatically or manually for each channel, see Section 4.13.4.2 and 4.13.4.3.
- Adding a bipolar recorder offset to the signal, if required (Section 4.13.4.2).

In its standard configuration, the analyzer's outputs can be set for the following DC voltages. Each range is usable from -5% to +5% of the nominal range.

Table 4-16: Analog Output Voltage Ranges

RANGE	MINIMUM OUTPUT	MAXIMUM OUTPUT
0-0.1 V	-5 mV	+105 mV
0-1 V	-0.05 V	+1.05 V
0-5 V	-0.25 V	+5.25 V
0-10 V	-0.5 V	+10.5 V
The default offset for all ranges is 0 VDC.		

The following DC current output limits apply to the current loop modules:

Table 4-17: Analog Output Current Loop Range

RANGE	MINIMUM OUTPUT	MAXIMUM OUTPUT
0-20 mA	0 mA	20 mA
These are the physical limits of the current loop modules, typical applications use 2-20 or 4-20 mA for the lower and upper limits. Please specify desired range when ordering this option. The default offset for all ranges is 0 mA.		

Pin assignments for the output connector at the rear panel of the instrument are shown in Table 4-18.

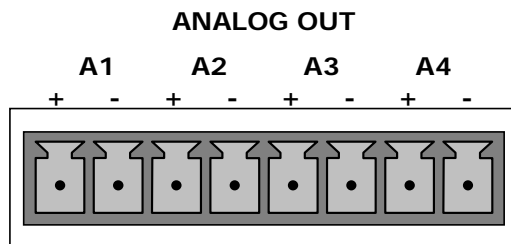

Table 4-18: Analog Output Pin Assignments

PIN	ANALOG OUTPUT	VOLTAGE SIGNAL	CURRENT SIGNAL
1	A1	V Out	I Out +
2		Ground	I Out -
3	A2	V Out	I Out +
4		Ground	I Out -
5	A3 ¹	V Out	I Out +
6		Ground	I Out -
7	A4	V Out	Not used
8		Ground	Not used

¹ Output A3 is only used when the O₂ sensor option is installed

See Figure 3-4 for the location of the analog output connector on the instrument's rear panel.

4.13.4.1. ANALOG OUTPUT SIGNAL TYPE AND RANGE SPAN SELECTION

To select an output signal type (DC Voltage or current) and level for one output channel, activate the ANALOG I/O CONFIGURATION MENU (see Section 4.13.4) then press:

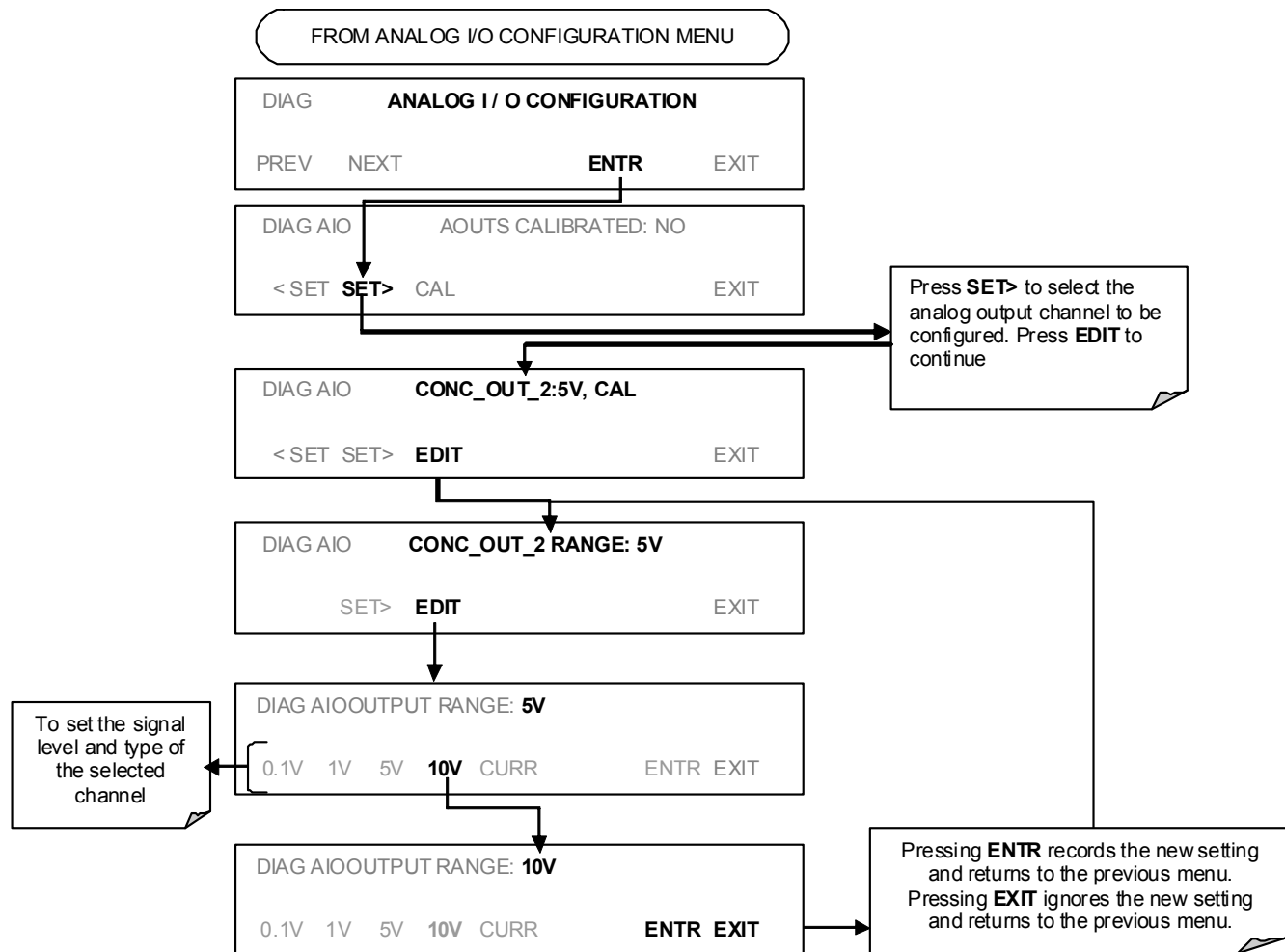

4.13.4.2. ANALOG OUTPUT CALIBRATION MODE

The analog outputs can be calibrated automatically or manually. In its default mode, the instrument is configured for automatic calibration of all channels. Manual calibration should be used for the 0.1V range or in cases where the outputs must be closely matched to the characteristics of the recording device. Outputs configured for automatic calibration can be calibrated as a group or individually. Calibration of the analog outputs needs to be carried out on first startup of the analyzer (performed in the factory as part of the configuration process) or whenever re-calibration is required.

To calibrate the outputs as a group, activate the ANALOG I/O CONFIGURATION MENU (see Section 4.13.1), then press:

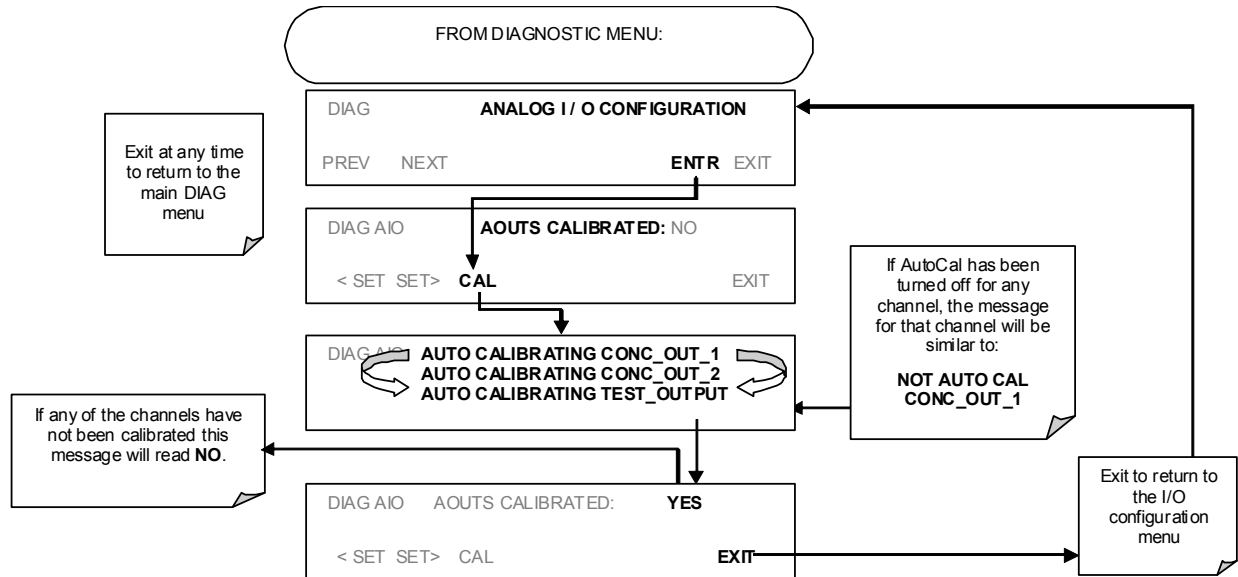

To automatically calibrate a single analog channel, activate the ANALOG I/O CONFIGURATION MENU (see Section 4.13.1), then press:

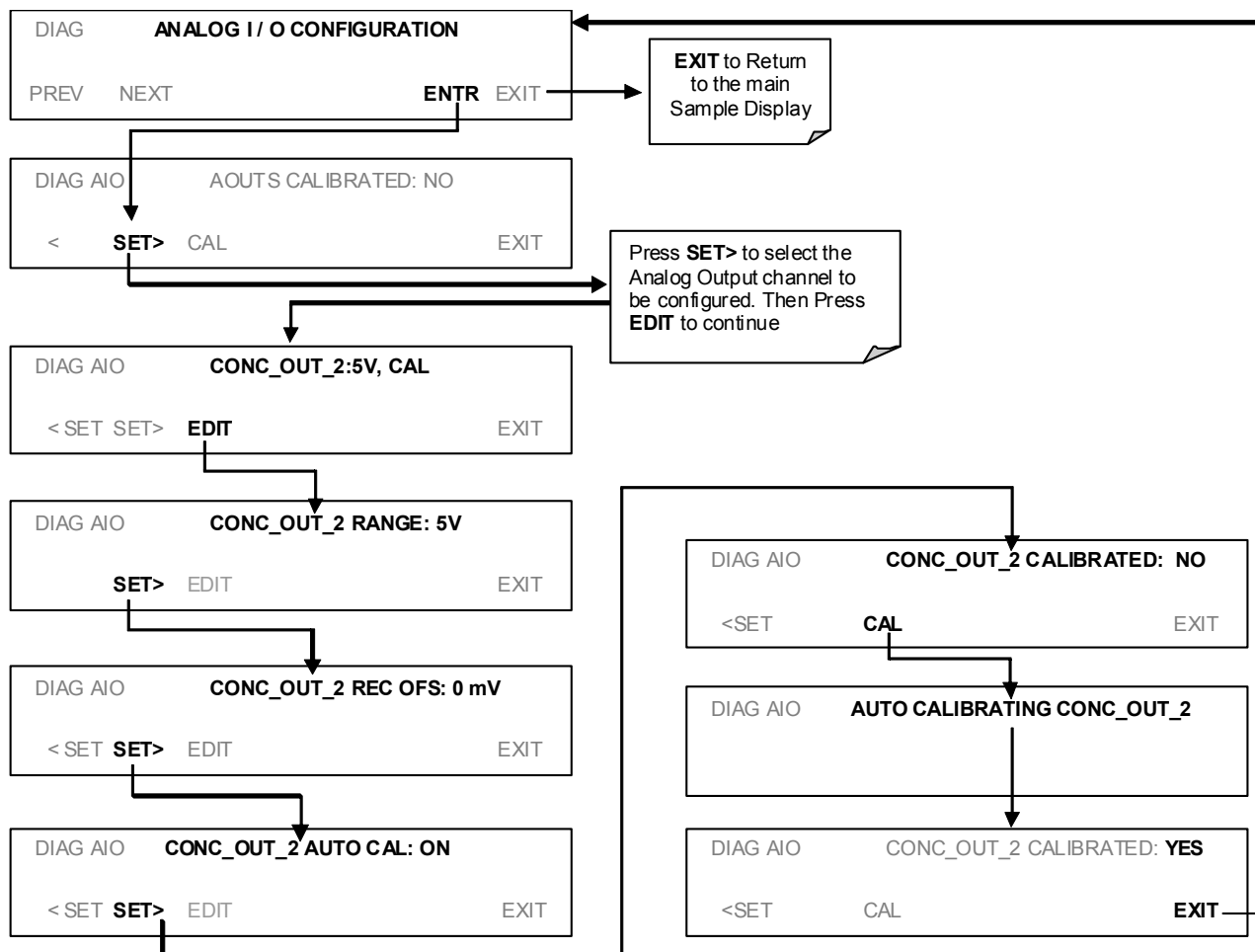

To select manual output calibration for a particular channel, activate the ANALOG I/O CONFIGURATION MENU (see Section 4.13.1), then press:

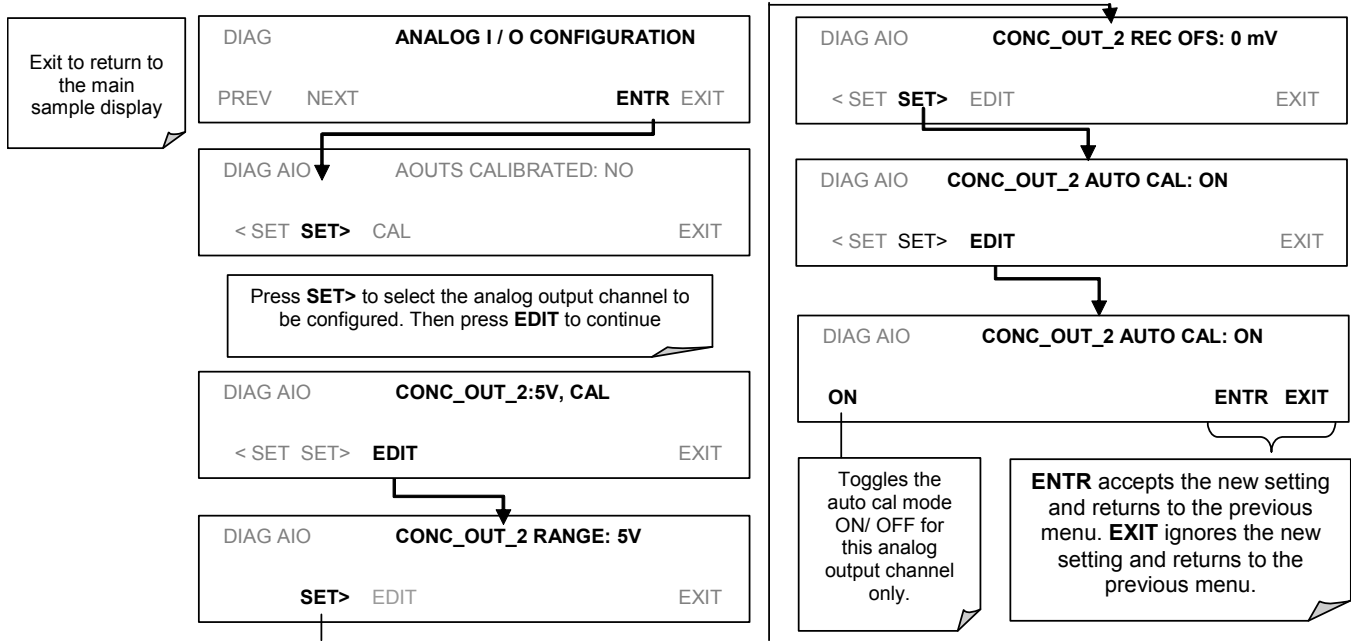

Now the analog output channels should either be automatically calibrated or they should be set to manual calibration, which is described next.

4.13.4.3. MANUAL ANALOG OUTPUT CALIBRATION AND VOLTAGE ADJUSTMENT

For highest accuracy, the voltages of the analog outputs can be manually calibrated. Calibration is done through the instrument software with a voltmeter connected across the output terminals (Figure 4-11). Adjustments are made using the touchscreen buttons by setting the zero-point first and then the span-point (Table 4-19).

The software allows this adjustment to be made in 100, 10 or 1 count increments.

Table 4-19: Voltage Tolerances for Analog Output Calibration

Full Scale	Zero Tolerance	Span Voltage	Span Tolerance
0.1 VDC	±0.0005V	90 mV	±0.001V
1 VDC	±0.001V	900 mV	±0.001V
5 VDC	±0.002V	4500 mV	±0.003V
10 VDC	±0.004V	4500 mV	±0.006V

NOTE

Outputs configured for 0.1V full scale should always be calibrated manually.

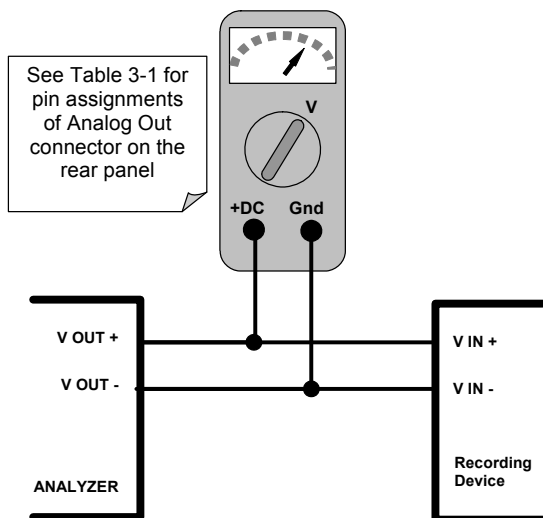
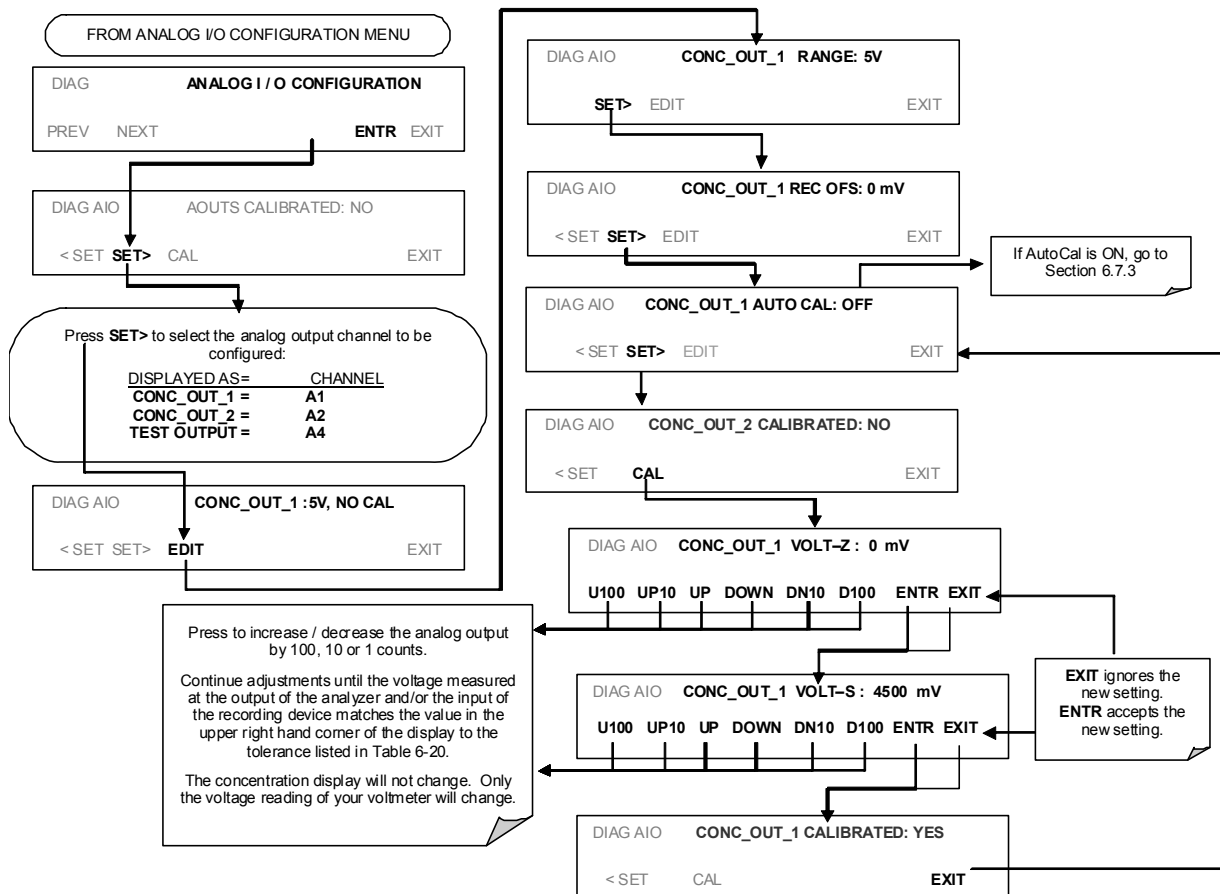

Figure 4-11: Setup for Calibrating Analog Voltage Outputs

To make these adjustments, the AOUT auto-calibration feature must be turned off (Section 4.13.4.2). Activate the ANALOG I/O CONFIGURATION MENU (see Section 4.13.1), then press:



4.13.4.4. CURRENT LOOP OUTPUT ADJUSTMENT

A current loop option is available and can be installed as a retrofit for each of the analog outputs of the analyzer (s 5.2). This option converts the DC voltage analog output to a current signal with 0-20 mA output current. The outputs can be scaled to any set of limits within that 0-20 mA range. However, most current loop applications call for either 2-20 mA or 4-20 mA range. All current loop outputs have a +5% over-range. Ranges with the lower limit set to more than 1 mA (e.g., 2-20 or 4-20 mA) also have a -5% under-range.

To switch an analog output from voltage to current loop after installing the current output printed circuit assembly, follow the instructions in 4.13.4.4 and select CURR from the list of options on the RANGE menu.

Adjusting the signal zero and span values of the current loop output is done by raising or lowering the voltage of the respective analog output. This proportionally raises or lowers the current produced by the current loop option.

Similar to the voltage calibration, the software allows this current adjustment to be made in 100, 10 or 1 count increments. Since the exact current increment per voltage count varies from output to output and from instrument to instrument, you will need to measure the change in the current with a current meter placed in series with the output circuit.

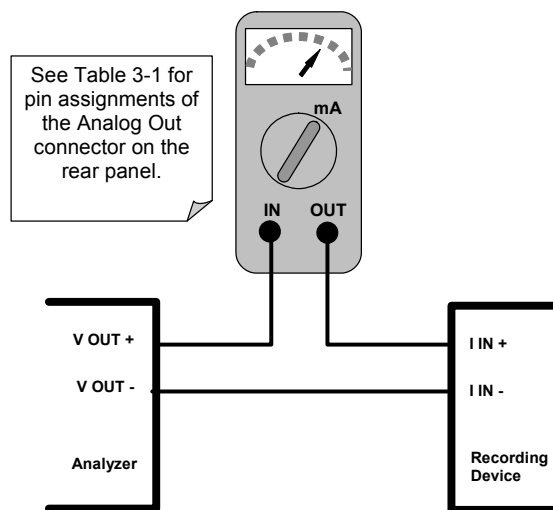
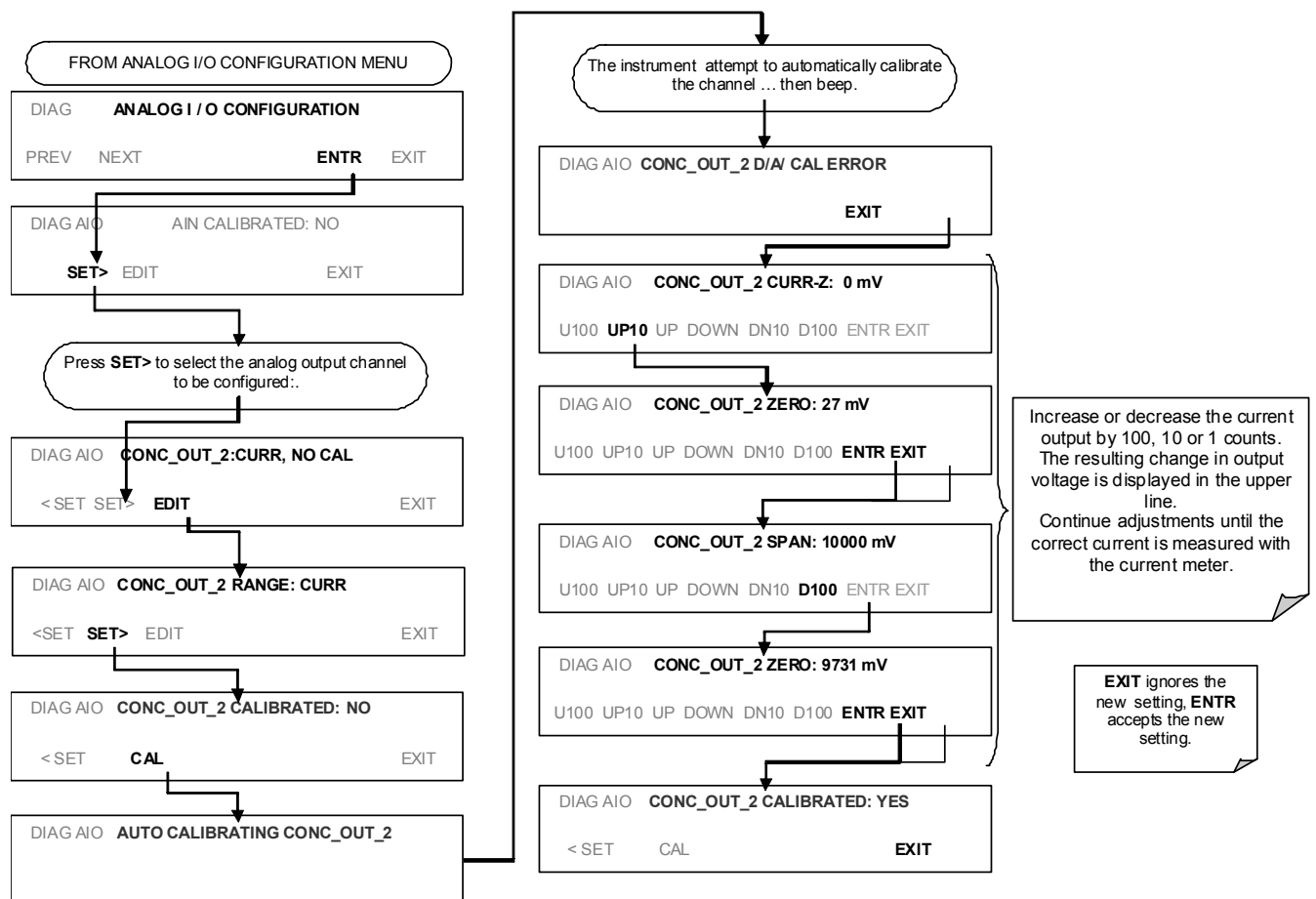

Figure 4-12: Setup for Calibrating Current Outputs

NOTE

Do not exceed 60 V between current loop outputs and instrument ground.

To adjust the zero and span values of the current outputs, activate the ANALOG I/O CONFIGURATION MENU (see Section 4.13.1), then press:



If a current meter is not available, an alternative method for calibrating the current loop outputs is to connect a 250 Ω ± 1% resistor across the current loop output. Using a voltmeter connected across the resistor, follow the procedure above but adjust the output to the following values:

Table 4-20: Current Loop Output Calibration with Resistor

Full scale	Voltage for 2-20 mA (measured across resistor)	Voltage for 4-20 mA (measured across resistor)
0%	0.5 V	1.0 V
100%	5.0 V	5.0 V

4.13.4.5. AIN CALIBRATION

This is the sub-menu to conduct the analog input calibration. This calibration should only be necessary after major repair such as a replacement of CPU, motherboard or power supplies. Activate the ANALOG I/O CONFIGURATION MENU (see Section 4.13.1), then press:

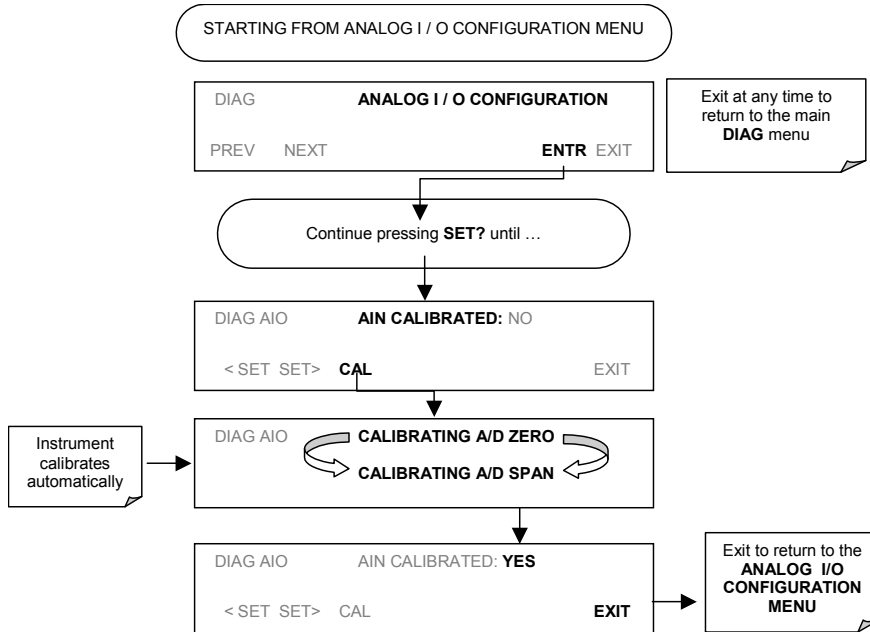

4.13.4.6. CONFIGURING ANALOG INPUTS (OPTION) CHANNELS

To configure the analyzer’s external analog inputs option, define for each channel:

- gain (number of units represented by 1 volt)
- offset (volts)
- engineering units to be represented in volts (each press of the touchscreen button scrolls the list of alphanumeric characters from A-Z and 0-9)
- whether to display the channel in the Test functions

To access and adjust settings for the external Analog Inputs option channels press:

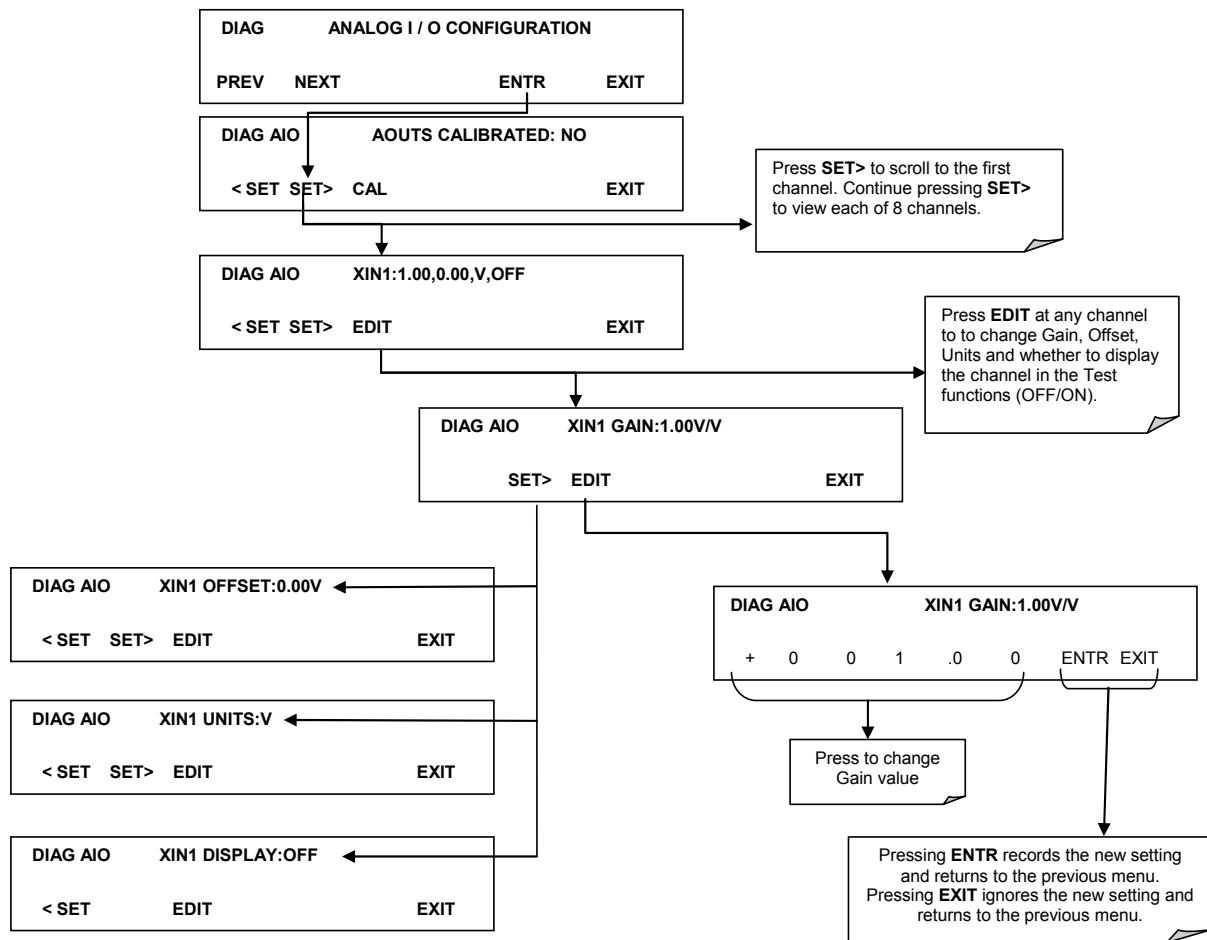

4.13.5. Electric Test

The electric test function substitutes simulated signals for **CO₂ MEAS** and **CO₂ REF**, generated by circuitry on the sync/demod board, for the output of the IR photo-detector. While in this mode the user can also view the same test functions viewable from the main **SAMPLE** display. When the test is running, the concentration reported on the front panel display should be **40.0** ppm.

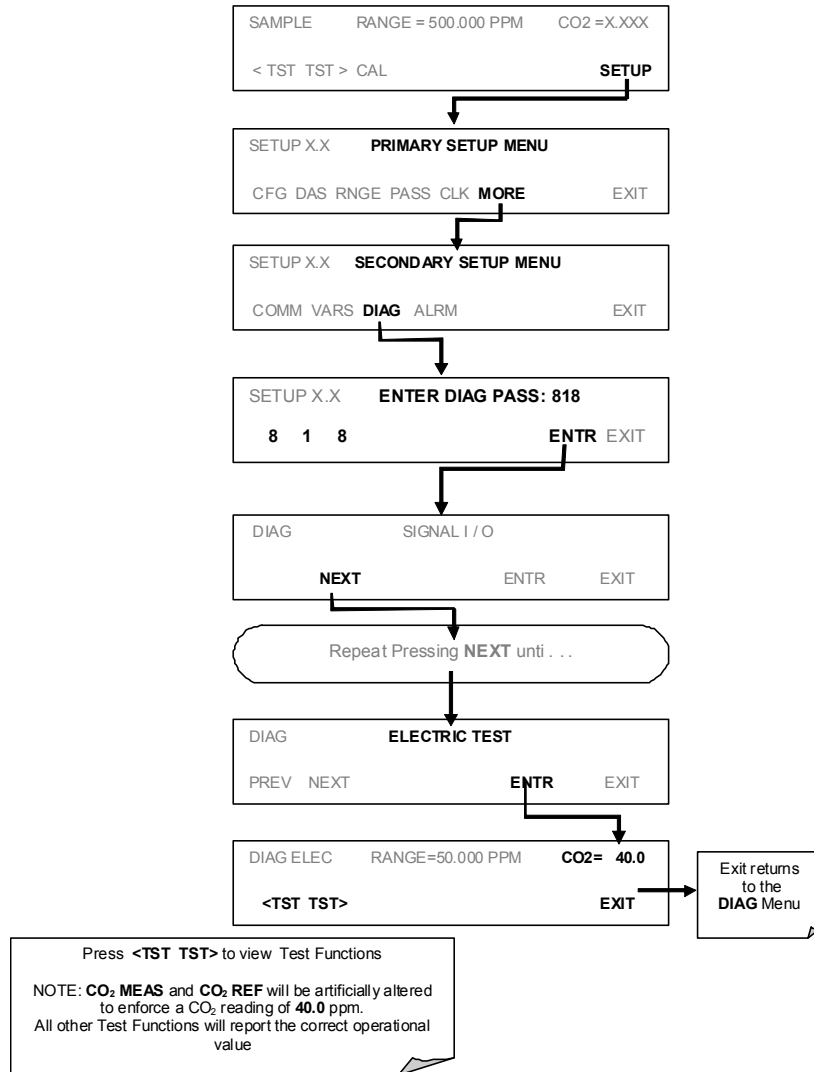

4.13.6. Dark Calibration Test

The dark calibration test interrupts the signal path between the IR photo-detector and the remainder of the sync/demod board circuitry. This allows the instrument to compensate for any voltage levels inherent in the sync/demod circuitry that might effect the calculation of CO₂ concentration. Performing this calibration returns two offset voltages, One for CO₂ MEAS and on for CO₂ REF that are automatically added to the CPU's calculation routine. The two offset voltages from the last calibration procedure may be reviewed by the user via the front panel display.

To activate the dark calibration procedure or review the results of a previous calibration, press:

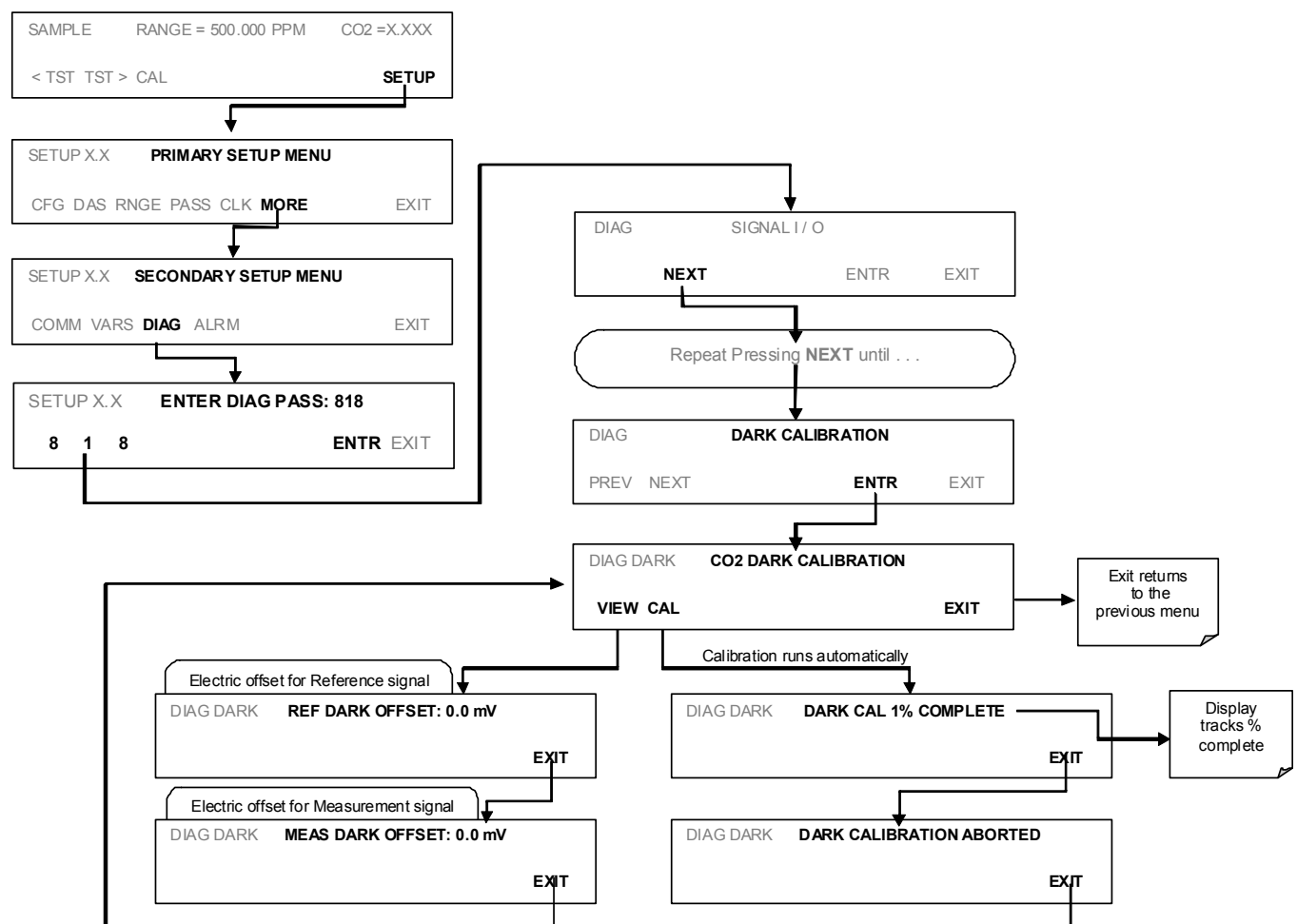

4.13.7. Pressure Calibration

A sensor at the exit of the sample chamber continuously measures the pressure of the sample gas. This data is used to compensate the final CO₂ concentration calculation for changes in atmospheric pressure and is stored in the CPU's memory as the test function **PRES** (also viewable via the front panel).

NOTE

This calibration must be performed when the pressure of the sample gas is equal to ambient atmospheric pressure.

Before performing the following pressure calibration procedure, disconnect the sample gas pump and the sample gas-line vent from the sample gas inlet on the instrument's rear panel.

To cause the analyzer to measure and record a value for **PRES**, press.

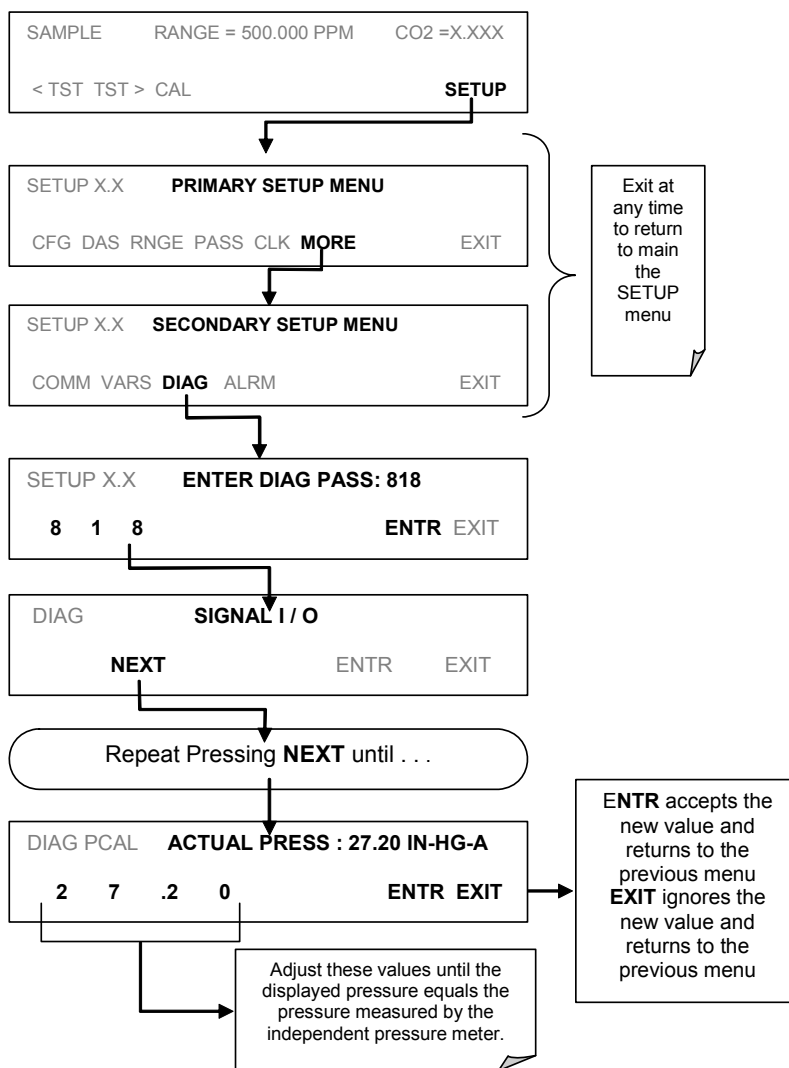

4.13.8. Flow Calibration

The flow calibration allows the user to adjust the values of the sample flow rates as they are displayed on the front panel and reported through COM ports to match the actual flow rate measured at the sample inlet. This does not change the hardware measurement of the flow sensors, only the software calculated values.

To carry out this adjustment, connect an external, sufficiently accurate flow meter to the sample inlet (see Section 6.3.4 for more details). Once the flow meter is attached and is measuring actual gas flow, press:

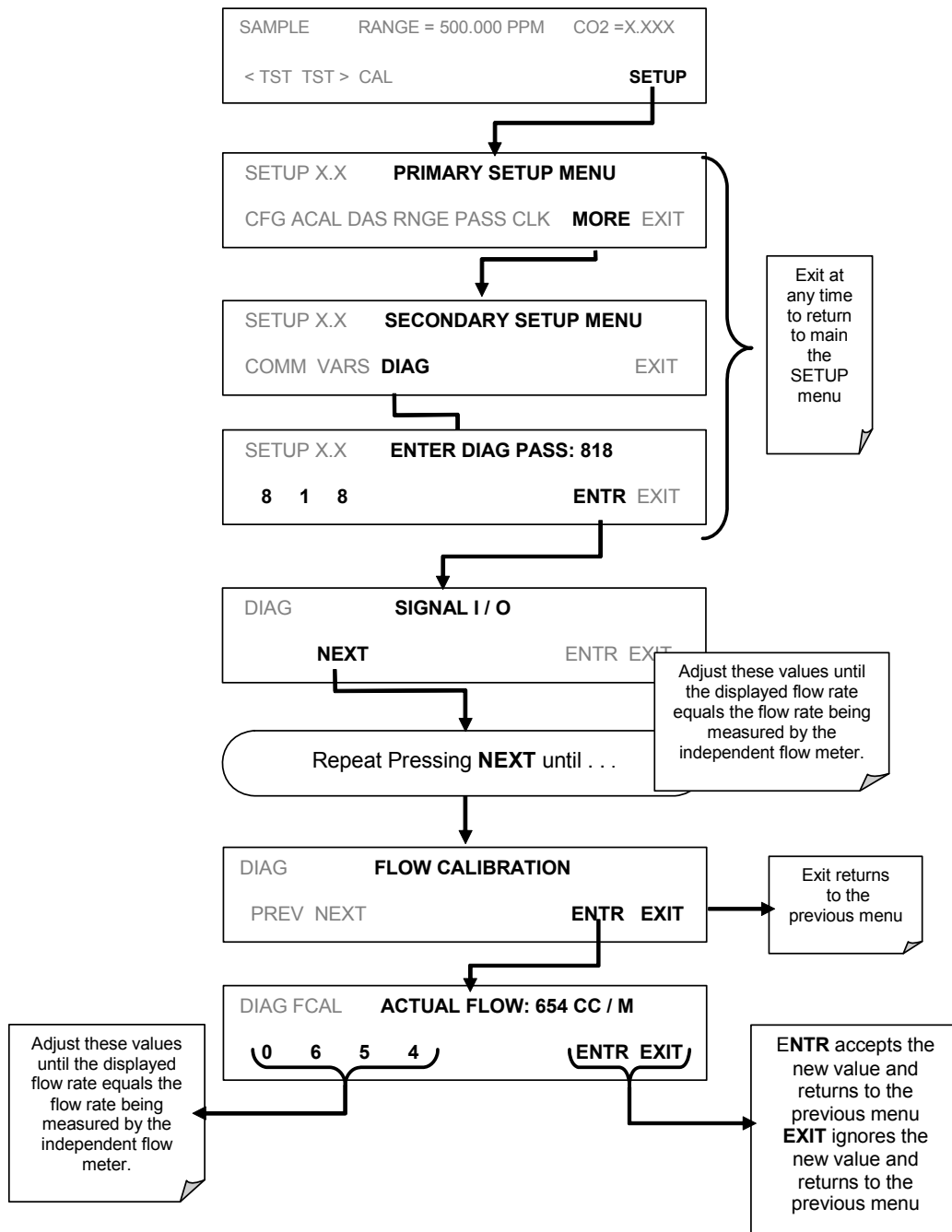

4.13.9. Test Channel Output

When activated, output channel **A4** can be used to report one of the test functions viewable from the SAMPLE mode display. To activate the **A4** channel and select a test function, follow this button sequence:

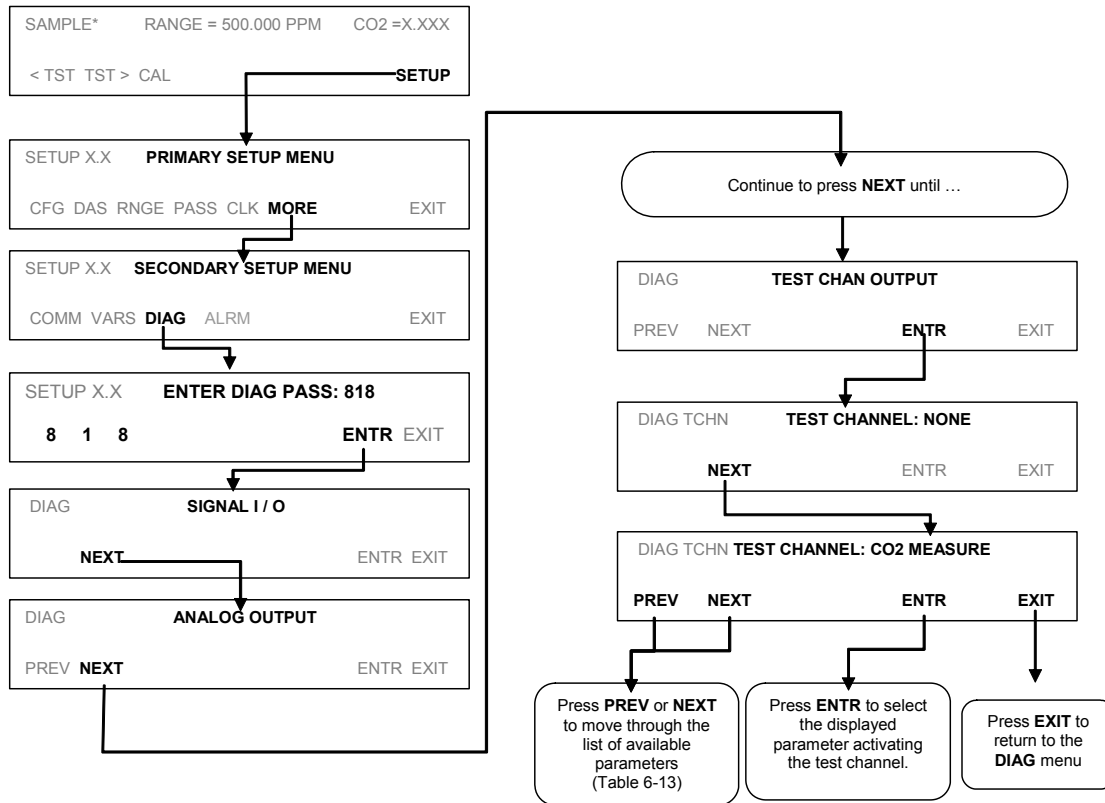

Table 4-21: Test Parameters Available for Analog Output A4

TEST CHANNEL	ZERO	FULL SCALE
NONE	Test Channel is turned off	
CO ₂ MEASURE	0 mV	5000 mV*
CO ₂ REFERENCE	0 mV	5000 mV*
SAMPLE PRESS	0 "Hg	40 "Hg
SAMPLE FLOW	0 cc/m	1000 cc/m
SAMPLE TEMP	0°C	70°C
BENCH TEMP	0°C	70°C
WHEEL TEMP	0°C	70°C
CHASSIS TEMP	0°C	70°C
PHT DRIVE	0 mV	5000 mV

* This refers to the internal voltage level of the function NOT the output signal level of the Test channel itself.

4.14. SETUP → MORE → ALRM: USING THE GAS CONCENTRATION ALARMS

The Model T360 includes two CO₂ concentration alarms. Each alarm has a user settable limit, and is associated with an opto-isolated TTL relay accessible via the status output connector on the instrument's back panel (see Section 4.15.1.1). If the CO₂ concentration measured by the instrument rises above that limit, the alarm's status output relay is closed.

The default settings for ALM1 and ALM2 are:

Table 4-22: CO₂ Concentration Alarm Default Settings

ALARM	STATUS	LIMIT SET POINT ¹
ALM1	Disabled	100 ppm
ALM2	Disabled	300 ppm

¹Set points listed are for PPM. Should the reporting range units of measure be changed (see Section 4.8.2) the analyzer will automatically scale the set points to match the new range unit setting.

Note

To prevent the concentration alarms from activating during span calibration operations make sure to press CAL or CALS button prior to introducing span gas into the analyzer.

4.14.1. Setting the Concentration Alarm Limits

To enable either of the CO₂ concentration alarms and set the Limit points, press:

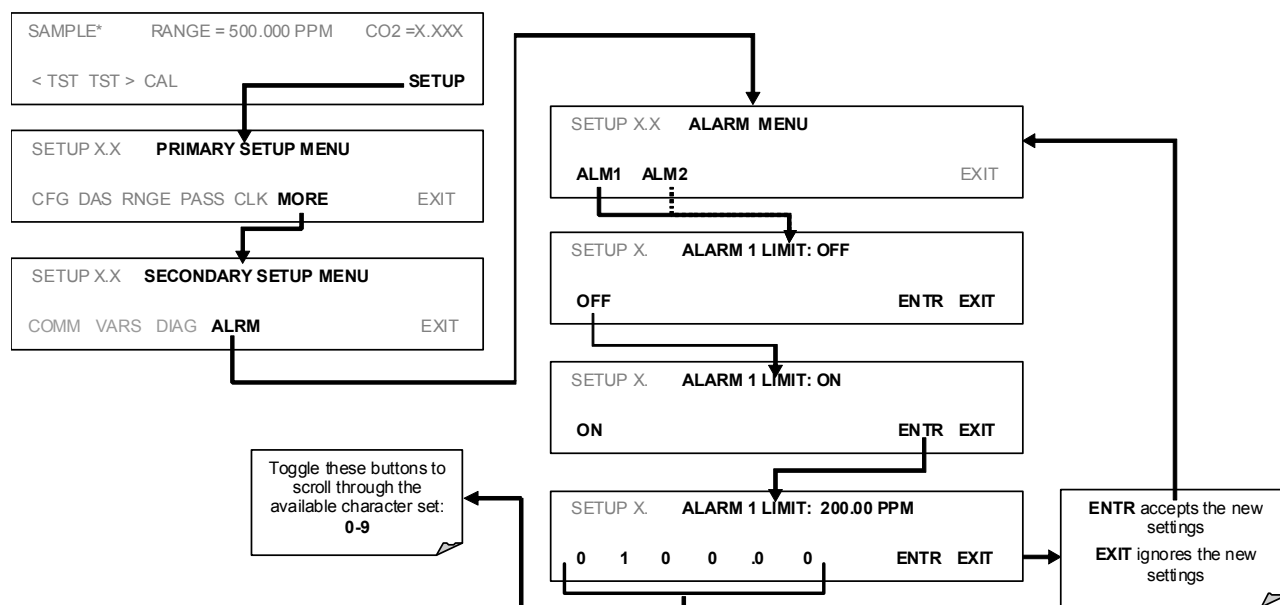

4.15. REMOTE OPERATION OF THE ANALYZER

4.15.1. Remote Operation Using the External Digital I/O

4.15.1.1. STATUS OUTPUTS

The status outputs report analyzer conditions via optically isolated NPN transistors, which sink up to 50 mA of DC current. These outputs can be used interface with devices that accept logic-level digital inputs, such as programmable logic controllers (PLC's). Each Status bit is an open collector output that can withstand up to 40 VDC. All of the emitters of these transistors are tied together and available at D (Figure 4-13).

NOTE

Most PLC's have internal provisions for limiting the current that the input will draw from an external device. When connecting to a unit that does not have this feature, an external dropping resistor must be used to limit the current through the transistor output to less than 50 mA. At 50 mA, the transistor will drop approximately 1.2V from its collector to emitter.

The status outputs are accessed via a 12-pin connector on the analyzer's rear panel labeled STATUS. The function of each pin is defined in Table 4-23.

STATUS

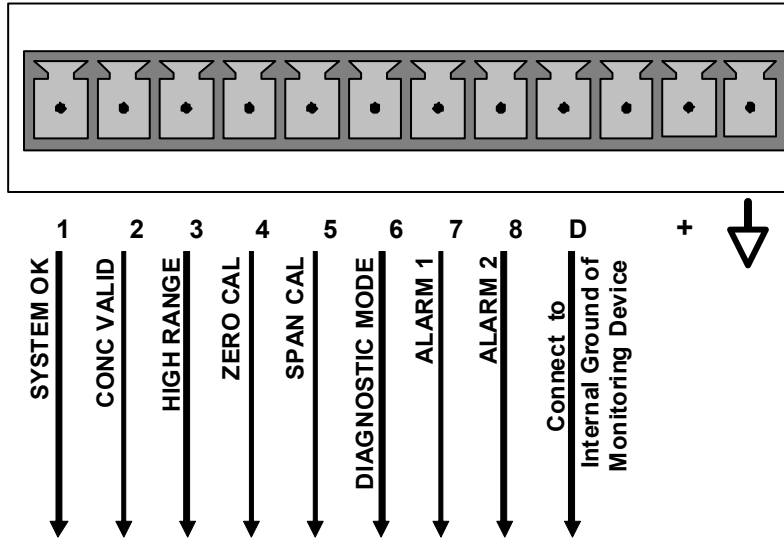



Figure 4-13: Status Output Connector

The pin assignments for the Status Outputs are:

Table 4-23: Status Output Pin Assignments

OUTPUT #	Status Definition	Condition
1	SYSTEM OK	On if no faults are present.
2	CONC VALID	On if CO ₂ concentration measurement is valid. If the CO ₂ concentration measurement is invalid, this bit is OFF.
3	HIGH RANGE	On if unit is in high range of DUAL or AUTO range modes.
4	ZERO CAL	On whenever the instruments zero point is being calibrated.
5	SPAN CAL	On whenever the instruments span point is being calibrated.
6	DIAG MODE	On whenever the instrument is in diagnostic mode.
7	ALARM1	On whenever the measured CO ₂ concentration is above the set point for ALM1
8	ALARM2	On whenever the measured CO ₂ concentration is above the set point for ALM2
D	EMITTER BUS	The emitters of the transistors on pins 1-8 are bused together.
+	DC POWER	+ 5 VDC
	Digital Ground	The ground level from the analyzer's internal DC power supplies.

4.15.1.2. CONTROL INPUTS

These inputs allow the user to remotely initiate Zero and Span calibrations. Two methods for energizing the inputs is provided below; the first using the internal +5V available on the CONTROL IN connector and the second, if an external, isolated supply is employed.

Table 4-24: Control Input Pin Assignments

INPUT	STATUS	CONDITION WHEN ENABLED
A	EXTERNAL ZERO CAL	Zero calibration mode is activated. The mode field of the display will read ZERO CAL R.
B	EXTERNAL SPAN CAL	Span calibration mode is activated. The mode field of the display will read SPAN CAL R.
C		Unused
D		Unused
E		Unused
F		Unused
↓	DIGITAL GROUND	Provided to ground an external device (e.g., recorder).
U	DC power for Input pull ups	Input for +5 VDC required to activate inputs A - F. This voltage can be taken from an external source or from the "+" pin.
+	Internal +5V Supply	Internal source of +5V which can be used to activate inputs when connected to pin U.

There are two methods to activate control inputs. The internal +5V available from the "+" pin is the most convenient method (Figure 4-14, left). However, to ensure that these inputs are truly isolated, a separate, external 5 VDC power supply (Figure 4-14, right) should be used.

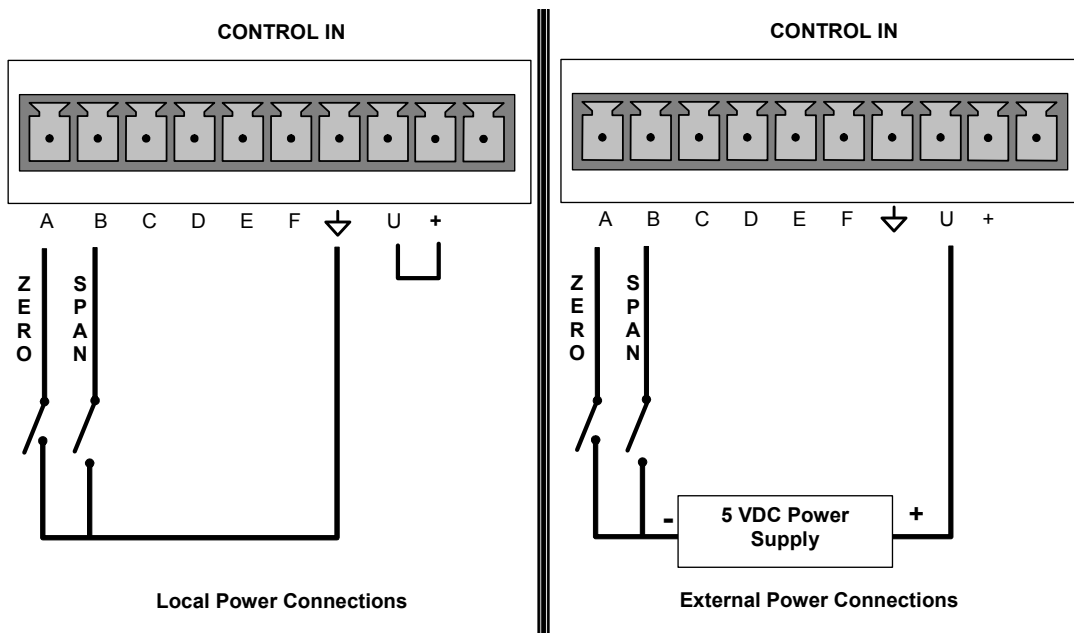

Figure 4-14: Control Inputs

4.15.2. Remote Operation Using the External Serial I/O

4.15.2.1. TERMINAL OPERATING MODES

The Model T360 can be remotely configured, calibrated or queried for stored data through the serial ports. As terminals and computers use different communication schemes, the analyzer supports two communicate modes specifically designed to interface with these two types of devices.

- **Computer mode** is used when the analyzer is connected to a computer with a dedicated interface program such as APICOM. More information regarding APICOM can be found in later in this or on the Teledyne API website at <http://www.teledyne-api.com/software/apicom/>.
- **Interactive mode** is used with a terminal emulation programs such as HyperTerminal or a “dumb” computer terminal. The commands that are used to operate the analyzer in this mode are listed in Table 4-25.

4.15.2.2. HELP COMMANDS IN TERMINAL MODE

Table 4-25: Terminal Mode Software Commands

COMMAND	Function
Control-T	Switches the analyzer to terminal mode (echo, edit). If mode flags 1 & 2 are OFF, the interface can be used in interactive mode with a terminal emulation program.
Control-C	Switches the analyzer to computer mode (no echo, no edit).
CR (carriage return)	A carriage return is required after each command line is typed into the terminal/computer. The command will not be sent to the analyzer to be executed until this is done. On personal computers, this is achieved by pressing the ENTER button.
BS (backspace)	Erases one character to the left of the cursor location.
ESC (escape)	Erases the entire command line.
? [ID] CR	This command prints a complete list of available commands along with the definitions of their functionality to the display device of the terminal or computer being used. The ID number of the analyzer is only necessary if multiple analyzers are on the same communications line, such as the multi-drop setup.
Control-C	Pauses the listing of commands.
Control-P	Restarts the listing of commands.

4.15.2.3. COMMAND SYNTAX

Commands are not case-sensitive and all arguments within one command (i.e. ID numbers, keywords, data values, etc.) must be separated with a space character.

All Commands follow the syntax:

X [ID] COMMAND <CR>

Where

- X** is the command type (one letter) that defines the type of command. Allowed designators are listed in Table 4-26 and Appendix A-6.
- [ID]** is the analyzer identification number (Section 4.11.1). Example: the Command “? 200” followed by a carriage return would print the list of available commands for the revision of software currently installed in the instrument assigned ID Number 200.
- COMMAND** is the command designator: This string is the name of the command being issued (LIST, ABORT, NAME, EXIT, etc.). Some commands may have additional arguments that define how the command is to be executed. Press ? <CR> or refer to Appendix A-6 for a list of available command designators.
- <CR>** is a carriage return. All commands must be terminated by a carriage return (usually achieved by pressing the ENTER button on a computer).

Table 4-26: Command Types

COMMAND	COMMAND TYPE
C	Calibration
D	Diagnostic
L	Logon
T	Test measurement
V	Variable
W	Warning

4.15.2.4. DATA TYPES

Data types consist of integers, hexadecimal integers, floating-point numbers, Boolean expressions and text strings.

- Integer data are used to indicate integral quantities such as a number of records, a filter length, etc. They consist of an optional plus or minus sign, followed by one or more digits. For example, +1, -12, 123 are all valid integers.
- Hexadecimal integer data are used for the same purposes as integers. They consist of the two characters “0x,” followed by one or more hexadecimal digits (0-9, A-F, a-f), which is the ‘C’ programming language convention. No plus or minus sign is permitted. For example, 0x1, 0x12, 0x1234abcd are all valid hexadecimal integers.
- Floating point numbers are used to specify continuously variable values such as temperature set points, time intervals, warning limits, voltages, etc. They

consist of an optional plus or minus sign, followed by zero or more digits, an optional decimal point, and zero or more digits. (At least one digit must appear before or after the decimal point.) Scientific notation is not permitted. For example, *+1.0*, *1234.5678*, *-0.1*, *1* are all valid floating-point numbers.

- Boolean expressions are used to specify the value of variables or I/O signals that may assume only two values. They are denoted by the keywords *ON* and *OFF*.
- Text strings are used to represent data that cannot be easily represented by other data types, such as data channel names, which may contain letters and numbers. They consist of a quotation mark, followed by one or more printable characters, including spaces, letters, numbers, and symbols, and a final quotation mark. For example, *"a"*, *"1"*, *"123abc"*, and *"()[]<>"* are all valid text strings. It is not possible to include a quotation mark character within a text string.
- Some commands allow you to access variables, messages, and other items, such as DAS data channels, by name. When using these commands, you must type the entire name of the item; you cannot abbreviate any names.

4.15.2.5. STATUS REPORTING

Reporting of status messages as an audit trail is one of the three principal uses for the RS-232 interface (the other two being the command line interface for controlling the instrument and the download of data in electronic format). You can effectively disable the reporting feature by setting the interface to quiet mode (Section 4.11.5, Table 4-9).

Status reports include DAS data (when reporting is enabled), warning messages, calibration and diagnostic status messages. Refer to Appendix A-3 for a list of the possible messages, and this for information on controlling the instrument through the RS-232 interface.

General Message Format

All messages from the instrument (including those in response to a command line request) are in the format:

X DDD:HH:MM [Id] MESSAGE<CRLF>

Where:

X is a command type designator, a single character indicating the message type, as shown in the Table Table 4-26.

DDD:HH:MM is the time stamp, the date and time when the message was issued. It consists of the Day-of-year (DDD) as a number from 1 to 366, the hour of the day (HH) as a number from 00 to 23, and the minute (MM) as a number from 00 to 59.

[ID] is the analyzer ID, a number with 1 to 4 digits.

MESSAGE is the message content that may contain warning messages, test measurements, DAS reports, variable values, etc.

<CRLF> is a carriage return / line feed pair, which terminates the message.

The uniform nature of the output messages makes it easy for a host computer to parse them into an easy structure. Keep in mind that the front panel display does not give any information on the time a message was issued, hence it is useful to log such messages for trouble-shooting and reference purposes. Terminal emulation programs such as HyperTerminal can capture these messages to text files for later review.

4.15.2.6. REMOTE ACCESS BY MODEM

The T360 can be connected to a modem for remote access. This requires a cable between the analyzer's COM port and the modem, typically a DB-9F to DB-25M cable (available from Teledyne API with part number WR0000024).

Once the cable has been connected, check to make sure the DTE-DCE is in the correct position. Also make sure the T360 COM port is set for a baud rate that is compatible with the modem, which needs to operate with an 8-bit word length with one stop bit.

The first step is to turn on the **MODEM ENABLE** communication mode (Mode 64, Section 4.11.5). Once this is completed, the appropriate setup command line for your modem can be entered into the analyzer. The default setting for this feature is

```
AT Y0 &D0 &H0 &I0 S0=2 &B0 &N6 &M0 E0 Q1 &W0
```

This string can be altered to match your modem's initialization and can be up to 100 characters long.

To change this setting press:

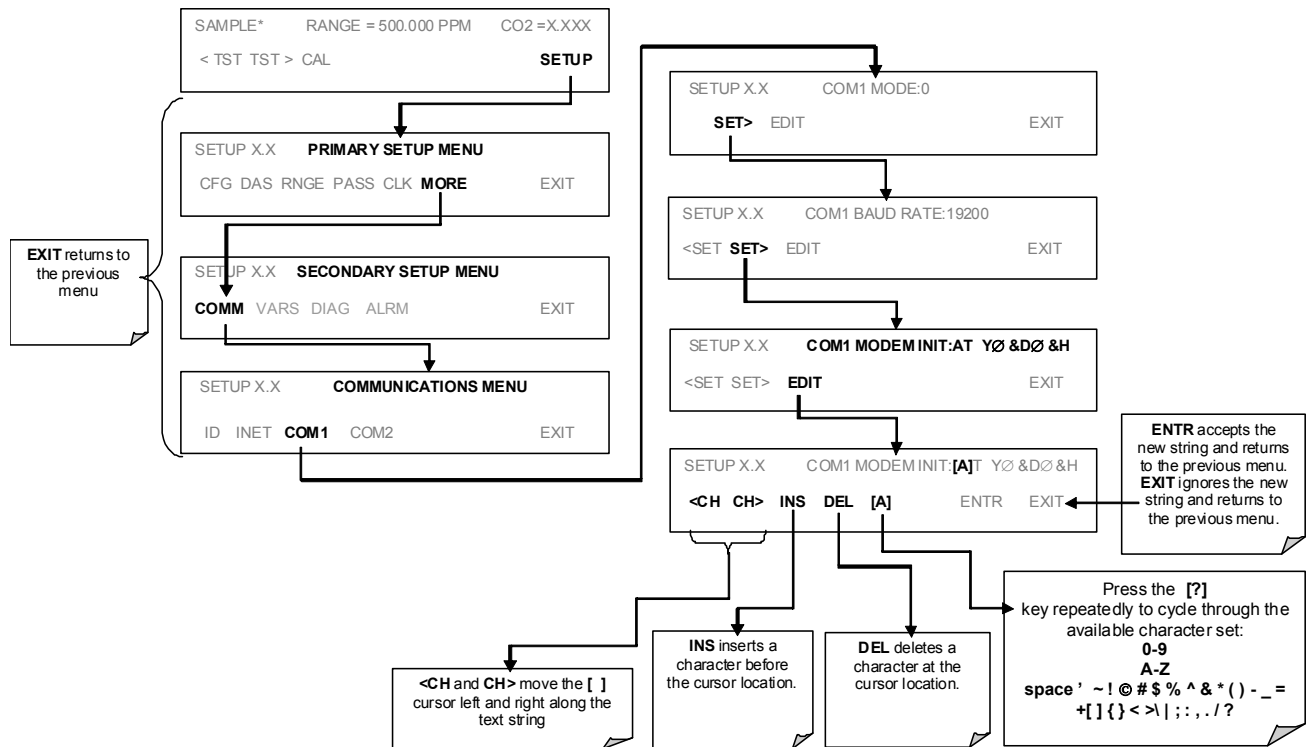

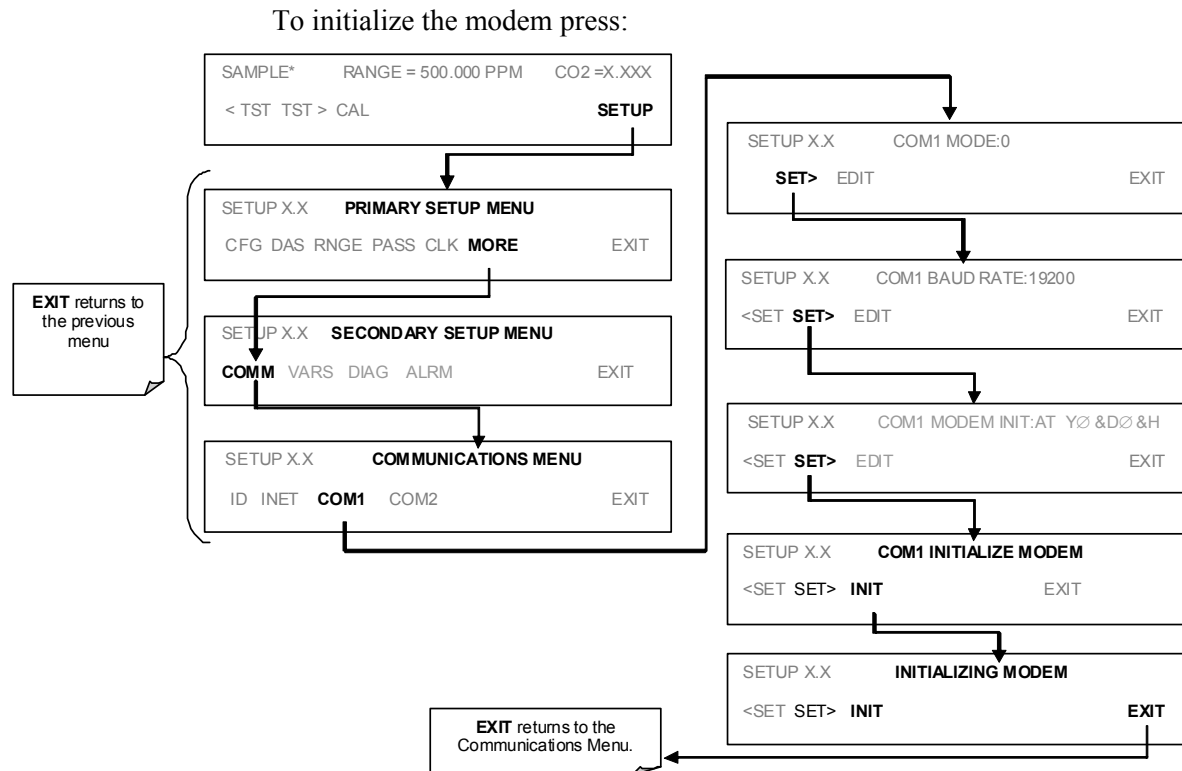

4.15.2.7. COM PORT PASSWORD SECURITY

In order to provide security for remote access of the T360, a LOGON feature can be enabled to require a password before the instrument will accept commands. This is done by turning on the **SECURITY MODE** (Mode 4, Section 4.11.5). Once the **SECURITY MODE** is enabled, the following items apply.

- A password is required before the port will respond or pass on commands.
- If the port is inactive for one hour, it will automatically logoff, which can also be achieved with the LOGOFF command.
- Three unsuccessful attempts to log on with an incorrect password will cause subsequent logins to be disabled for 1 hour, even if the correct password is used.
- If not logged on, the only active command is the '?' request for the help screen.
- The following messages will be returned at logon:
 - LOGON SUCCESSFUL - Correct password given
 - LOGON FAILED - Password not given or incorrect
 - LOGOFF SUCCESSFUL - Connection terminated successfully

To log on to the Model T360 analyzer with **SECURITY MODE** feature enabled, type:

LOGON 940331

940331 is the default password. To change the default password, use the variable RS232_PASS issued as follows:

```
V RS232_PASS=NNNNNN
```

Where N is any numeral between 0 and 9.

4.15.2.8. APICOM REMOTE CONTROL PROGRAM

APICOM is an easy-to-use, yet powerful interface program that allows accessing and controlling any of Teledyne API's main line of ambient and stack-gas instruments from a remote connection through direct cable, modem or Ethernet. Running APICOM, a user can:

Establish a link from a remote location to the T360 through direct cable connection via RS-232 modem or Ethernet.

- View the instrument's front panel and remotely access all functions that could be accessed when standing in front of the instrument.
- Remotely edit system parameters and set points.
- Download, view, graph and save data for predictive diagnostics or data analysis.
- Retrieve, view, edit, save and upload DAS configurations.
- Check on system parameters for trouble-shooting and quality control.

APICOM is very helpful for initial setup, data analysis, maintenance and trouble-shooting. Figure 4-15 shows an example of APICOM's main interface with DAS feature; the interface emulates the look and functionality of the instrument's actual front panel

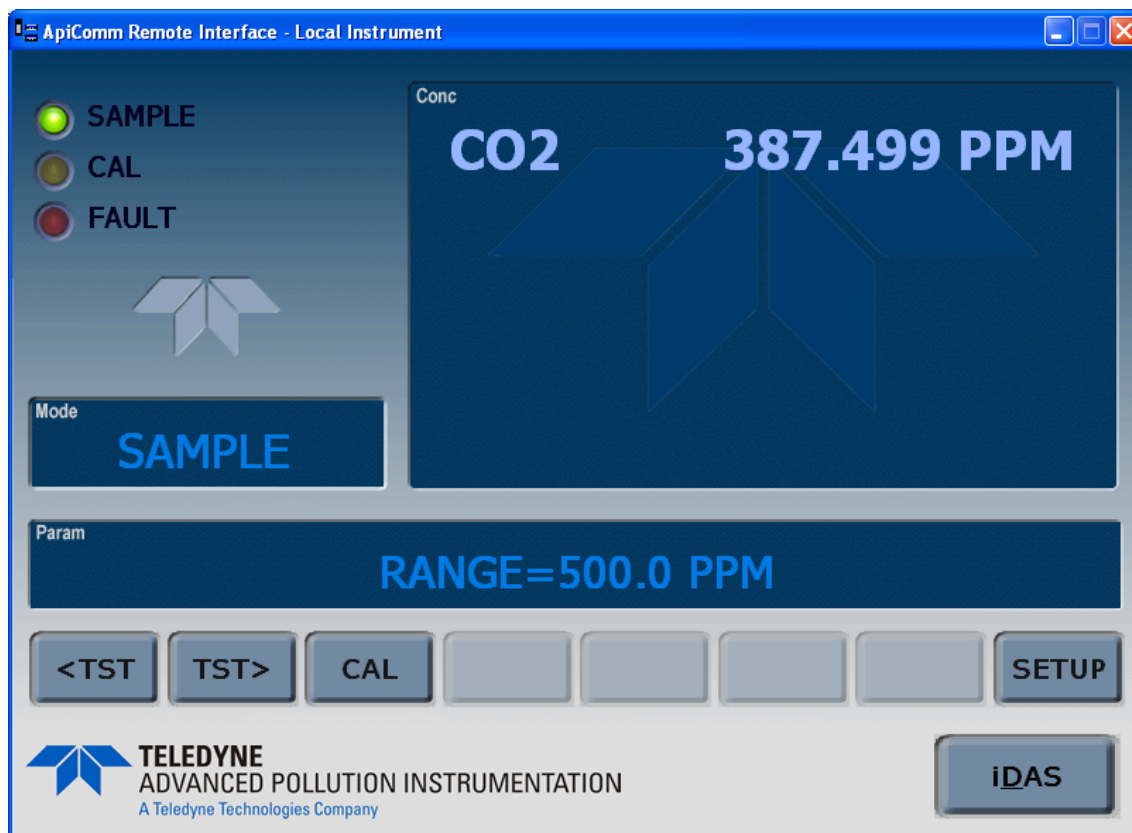

Figure 4-15: APICOM Remote Control Program Interface

APICOM is included free of cost with the analyzer and the latest versions can also be downloaded for free at <http://www.teledyne-api.com/software/apicom/>.

4.15.3. Additional Communications Documentation

Table 4-27: Serial Interface Documents

INTERFACE / TOOL	DOCUMENT TITLE	PART NUMBER	AVAILABLE ONLINE*
APICOM	APICOM User Manual	039450000	YES
DAS Manual	Detailed description of the DAS.	028370000	YES

* These documents can be downloaded at <http://www.teledyne-api.com/manuals/>

4.15.4. Using the T360 with a Hessen Protocol Network

4.15.4.1. GENERAL OVERVIEW OF HESSEN PROTOCOL

The Hessen protocol is a multidrop protocol, in which several remote instruments are connected via a common communications channel to a host computer. The remote instruments are regarded as slaves of the host computer. The remote instruments are unaware that they are connected to a multidrop bus and never initiate Hessen protocol messages. They only respond to commands from the host computer and only when they receive a command containing their own unique ID number.

The Hessen protocol is designed to accomplish two things: to obtain the status of remote instruments, including the concentrations of all the gases measured; and to place remote instruments into zero or span calibration or measure mode. API's implementation supports both of these principal features.

The Hessen protocol is not well defined, therefore while API's application is completely compatible with the protocol itself, it may be different from implementations by other companies.

The following subs describe the basics for setting up your instrument to operate over a Hessen Protocol network. For more detailed information as well as a list of host computer commands and examples of command and response message syntax, download the *Manual Addendum for Hessen Protocol* from the Teledyne API web site: <http://www.teledyne-api.com/manuals/index.asp>.

4.15.4.2. HESSEN COM PORT CONFIGURATION

Hessen protocol requires the communication parameters of the T360's com ports to be set differently than the standard configuration as shown in the table below.

Table 4-28: RS-232 Com Parameters for Hessen Protocol

Parameter	Standard	Hessen
Data Bits	8	7
Stop Bits	1	2
Parity	None	Even
Duplex	Full	Half

To change the rest of the com port parameters. See Section 4.11.5.

To change the baud rate of the T360's com ports, see Section 4.11.10.

NOTE

Ensure that the communication parameters of the host computer are also properly set.

Further note that the instrument software has a 200 ms. Latency before it responds to commands issued by the host computer. This latency should present no problems, but you should be aware of it and not issue commands to the instrument too frequently.

4.15.4.3. ACTIVATING HESSEN PROTOCOL

The first step in configuring the T360 to operate over a Hessen protocol network is to activate the Hessen mode for com ports and configure the communication parameters for the port(s) appropriately. Press:

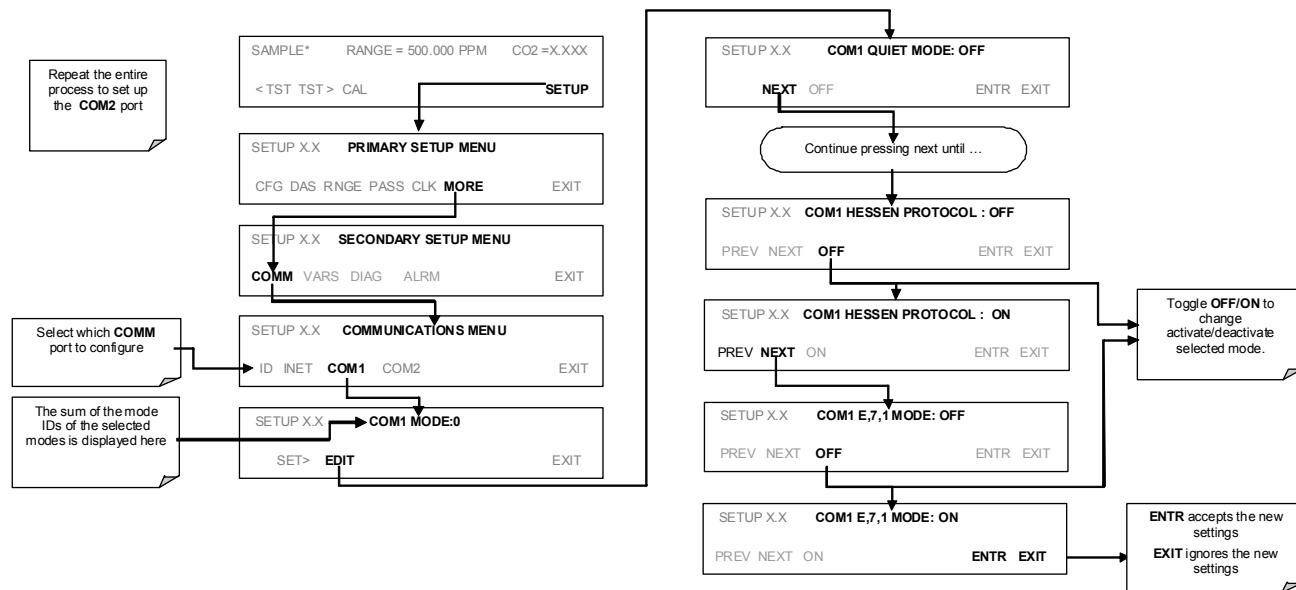

4.15.4.4. SELECTING A HESSEN PROTOCOL TYPE

Currently there are two versions of Hessen Protocol in use. The original implementation, referred to as **TYPE 1**, and a more recently released version, **TYPE 2** that has more flexibility when operating with instruments that can measure more than one type of gas. For more specific information about the difference between **TYPE 1** and **TYPE 2** download the *Manual Addendum for Hessen Protocol* from the Teledyne API web site: <http://www.teledyne-api.com/manuals/index.asp>.

To select a Hessen Protocol Type press:

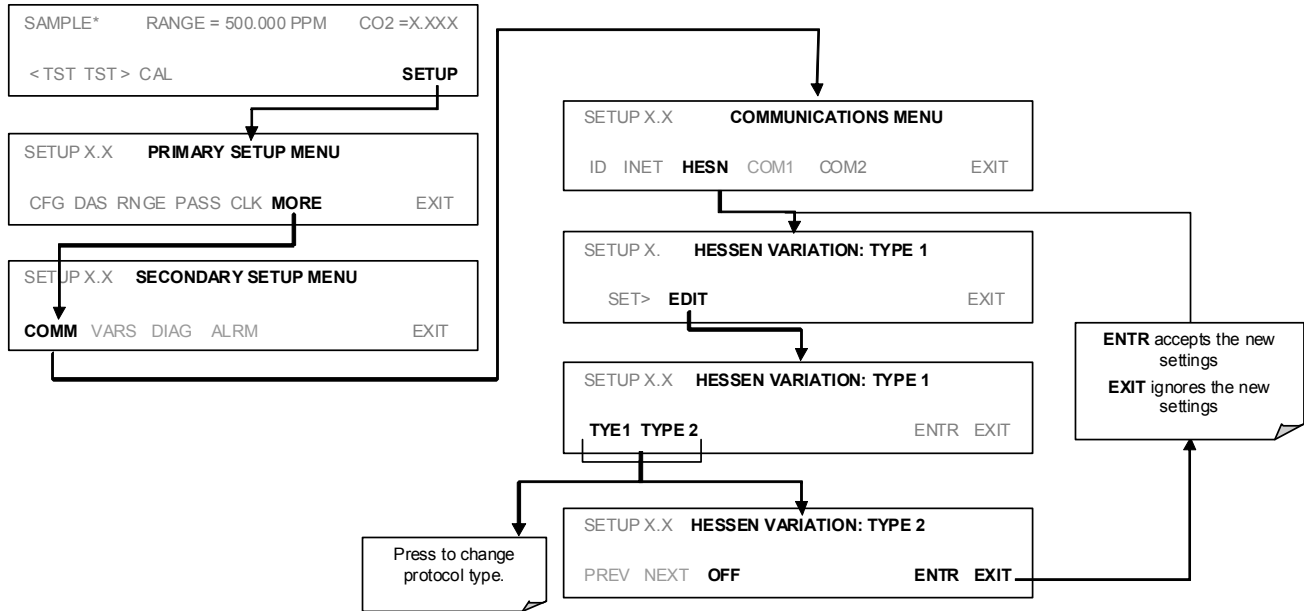

NOTE
While Hessen Protocol Mode can be activated independently for COM1 and COM2, The TYPE selection affects both Ports.

4.15.4.5. SETTING THE HESSEN PROTOCOL RESPONSE MODE

The Teledyne API implementation of Hessen Protocol allows the user to choose one of several different modes of response for the analyzer.

Table 4-29: Teledyne API Hessen Protocol Response Modes

MODE ID	MODE DESCRIPTION
CMD	This is the Default Setting. Responses from the instrument are encoded as the traditional command format. Style and format of responses depend on exact coding of the initiating command.
BCC	Responses from the instrument are always delimited with <STX> (at the beginning of the response, <ETX> (at the end of the response followed by a 2 digit Block Check Code (checksum), regardless of the command encoding.
TEXT	Responses from the instrument are always delimited with <CR> at the beginning and the end of the string, regardless of the command encoding.

To Select a Hessen response mode, press:

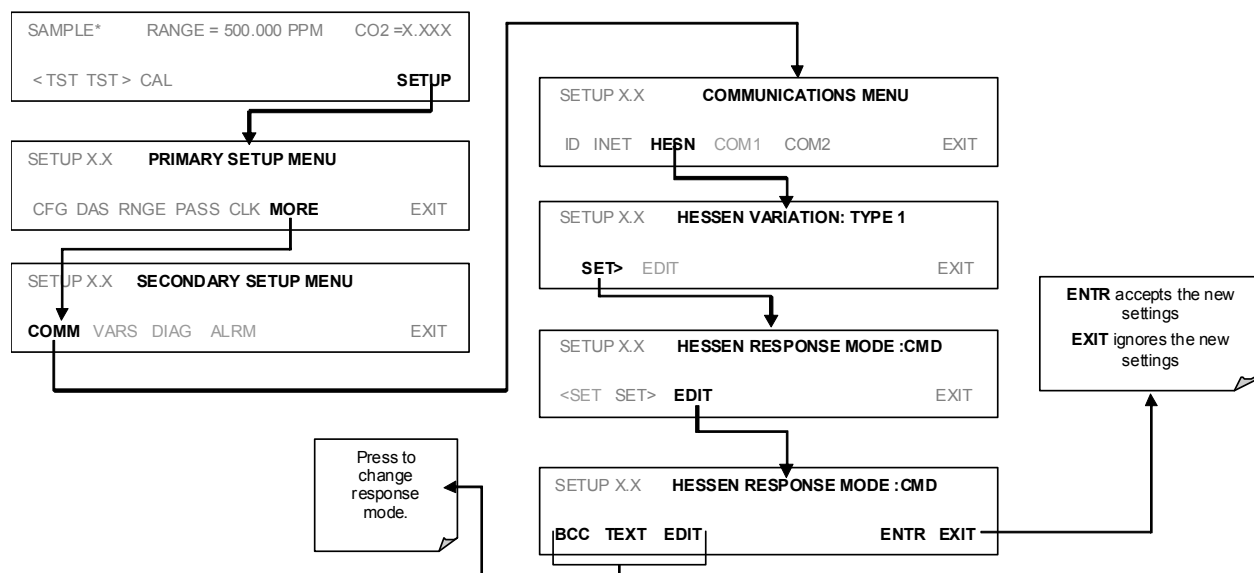

4.15.4.6. HESSEN PROTOCOL GAS ID

The Model T360 Analyzer is a single gas instrument that measures CO₂. As such it's default gas ID has already been set to **310**. There is no need to change this setting.

4.15.4.7. SETTING HESSEN PROTOCOL STATUS FLAGS

Teledyne API's implementation of Hessen protocols includes a set of status bits that the instrument includes in responses to inform the host computer of its condition. Each bit can be assigned to one operational and warning message flag. The default settings for these bit/flags are:

Table 4-30: Default Hessen Status Bit Assignments

STATUS FLAG NAME		DEFAULT BIT ASSIGNMENT
WARNING FLAGS		
SAMPLE FLOW WARNING		0001
BENCH TEMP WARNING		0002
SOURCE WARNING		0004
BOX TEMP WARNING		0008
WHEEL TEMP WARNING		0010
SAMPLE TEMP WARNING		0020
SAMPLE PRESSURE WARNING		0040
INVALID CONC (The Instrument's Front Panel Display Will Show The Concentration As "XXXX")		0080
OPERATIONAL FLAGS		
Instrument Off		0100
In Manual Calibration Mode		0200
In Zero Calibration Mode		0400
In Span Calibration Mode		0800
UNITS OF MEASURE FLAGS		
UGM		0000
MGM		2000
PPB		4000
PPM		6000
SPARE/UNUSED BITS		100, 1000, 8000
UNASSIGNED FLAGS (0000)		
Sync Warning	Relay Board Warning	
Conc Alarm 1	Analog Cal Warning	
Conc Alarm 2	Cannot Dyn Zero	
Photo Temp Warning	Cannot Dyn Span	
System Reset	Invalid Conc	
Rear Board Not Detected		

NOTES:

It is possible to assign more than one flag to the same Hessen status bit. This allows the grouping of similar flags, such as all temperature warnings, under the same status bit.

Be careful not to assign conflicting flags to the same bit as each status bit will be triggered if any of the assigned flags is active.

To assign or reset the status flag bit assignments, press:

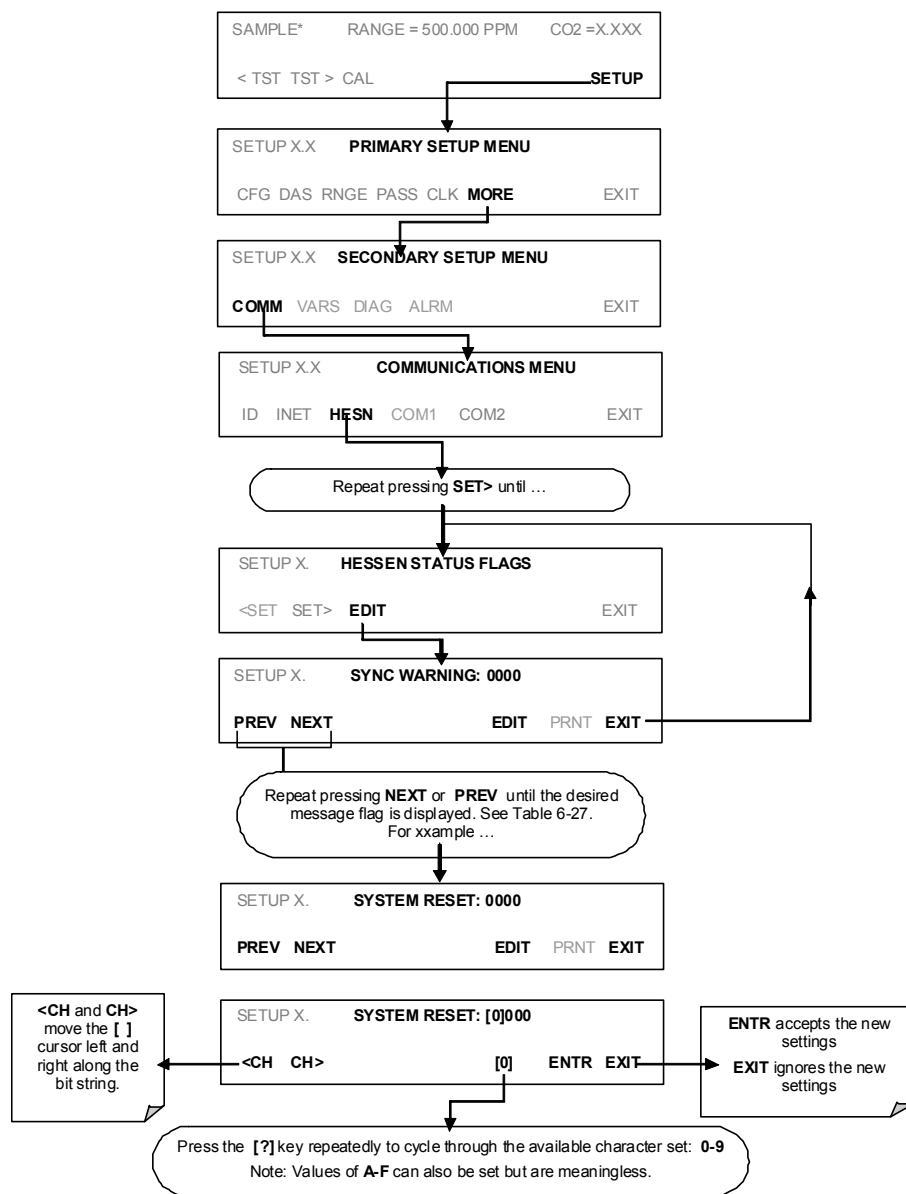

4.15.4.8. INSTRUMENT ID CODE

Each instrument on a Hessen Protocol network must have a unique ID code. The T360 is programmed with a default ID code of **360 OR 0**. To change this code See Section 4.11.1

This page intentionally left blank.

5. CALIBRATION PROCEDURES

This contains a variety of information regarding the various methods for calibrating a Model T360 CO₂ Analyzer as well as other supporting information.

NOTE

The procedures herein assume that the calibration password feature is disabled (the instrument's default state). If it is enabled, a password prompt screen (See Section 4.9) will appear after the CAL, CALZ or CALS buttons are pushed but before the instrument enters the associated calibration mode.

5.1. BEFORE CALIBRATION

The calibration procedures in this assume that the Range Type, Range Span and units of measure have already been selected for the analyzer. If this has not been done, please do so before continuing (see Section 4.8 for instructions).

All Gas lines should be PTFE (Teflon), FEP, glass, stainless steel or brass.

NOTE

If any problems occur while performing the following calibration procedures, refer to Section 8 of this manual for troubleshooting tips.

5.1.1. Zero Air and Span Gas

To perform the following calibration you must have sources for zero air and span gas available.

Zero Air is similar in chemical composition to the Earth's atmosphere but scrubbed of all components that might affect the analyzer's readings. Zero air should contain less than 25 ppb of CO₂ and other major interfering gases such as CO and Water Vapor. It should have a dew point of -5°C or less

Span Gas is a gas specifically mixed to match the chemical composition of the type of gas being measured at near full scale of the desired measurement range. It is recommended that the span gas used have a concentration equal to 80% of the full measurement range.

If Span Gas is sourced directly from a calibrated, pressurized tank, the gas mixture should be CO₂ mixed with Zero Air or N₂ at the required ratio.

5.1.2. Calibration Gas Traceability

All equipment used to produce calibration gases should be verified against standards of the National Institute for Standards and Technology (NIST). To ensure NIST traceability, we recommend acquiring cylinders of working gas that are certified to be traceable to NIST Standard Reference Materials (SRM). These are available from a variety of commercial sources.

5.1.3. Data Recording Devices

A strip chart recorder, data acquisition system or digital data acquisition system should be used to record data from the T360's serial or analog outputs. If analog readings are used, the response of the recording system should be checked against a NIST traceable voltage source or meter. Data recording device should be capable of bi-polar operation so that negative readings can be recorded. For electronic data recording, the T360 provides an internal data acquisition system (DAS), which is described in detail in Section 4.7.

5.2. MANUAL CALIBRATION WITHOUT ZERO/SPAN VALVES

This is the basic method for manually calibrating the Model T360 CO₂ Analyzer without functioning zero/span valve options. It is identical to the method described in the GETTING STARTED (Section 3) of this manual and is repeated here for your convenience.

STEP ONE: Connect the Sources of Zero Air and Span Gas as shown below.

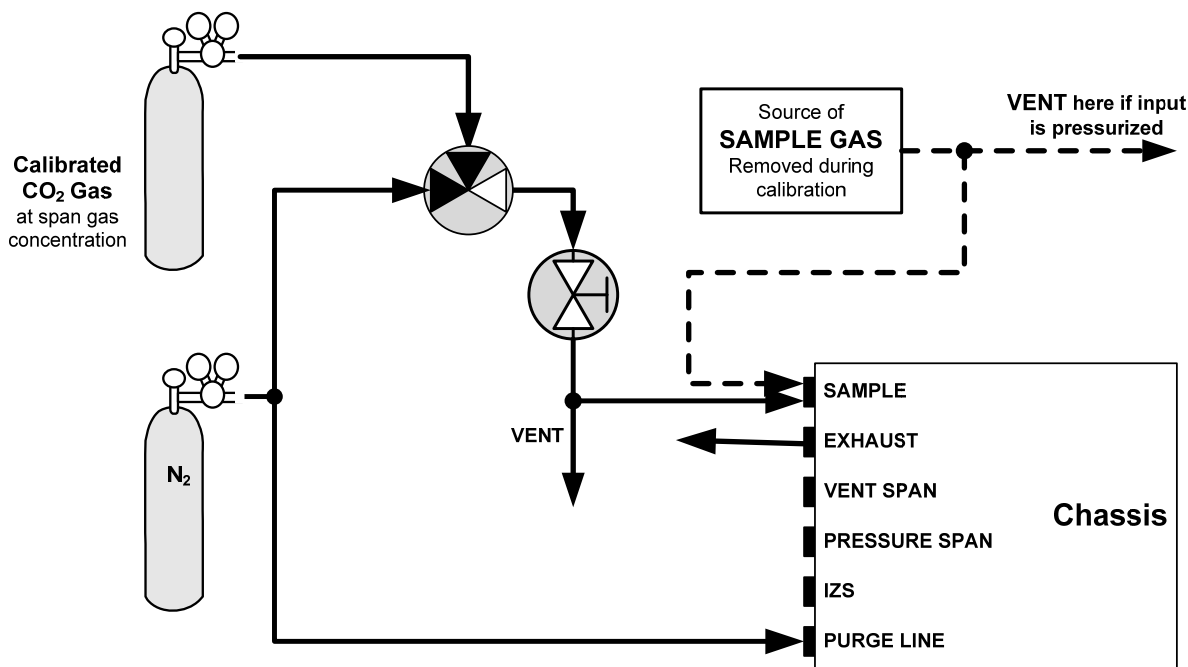

Figure 5-1: Pneumatic Connections—Basic Configuration—Using Bottled Span Gas

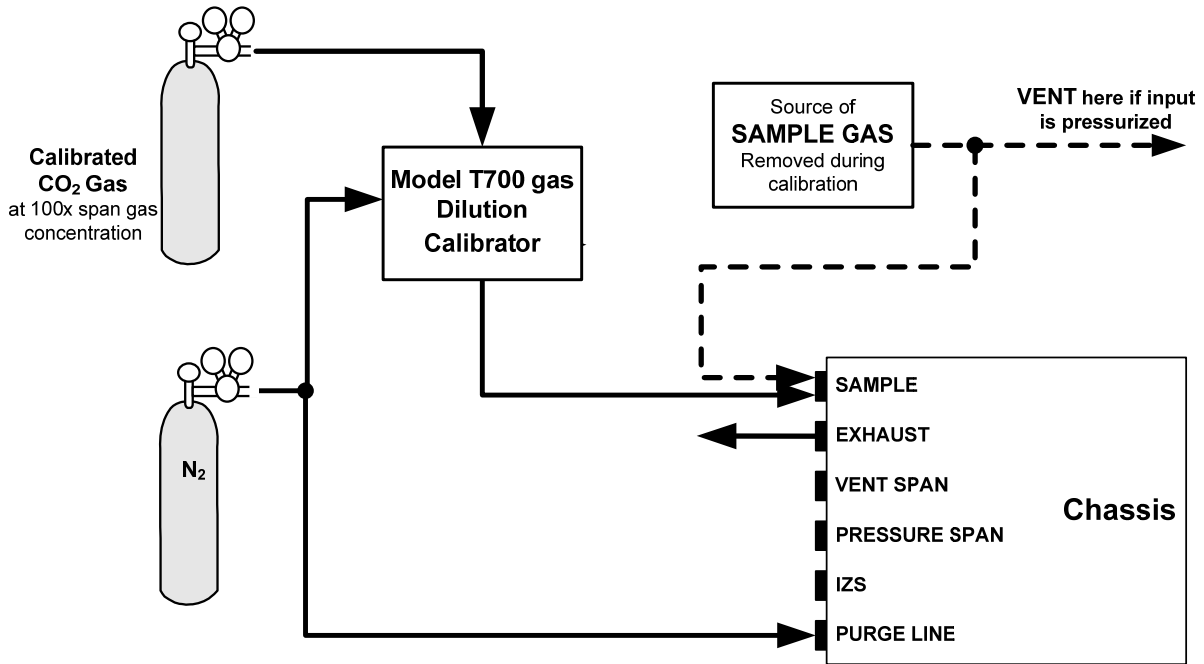
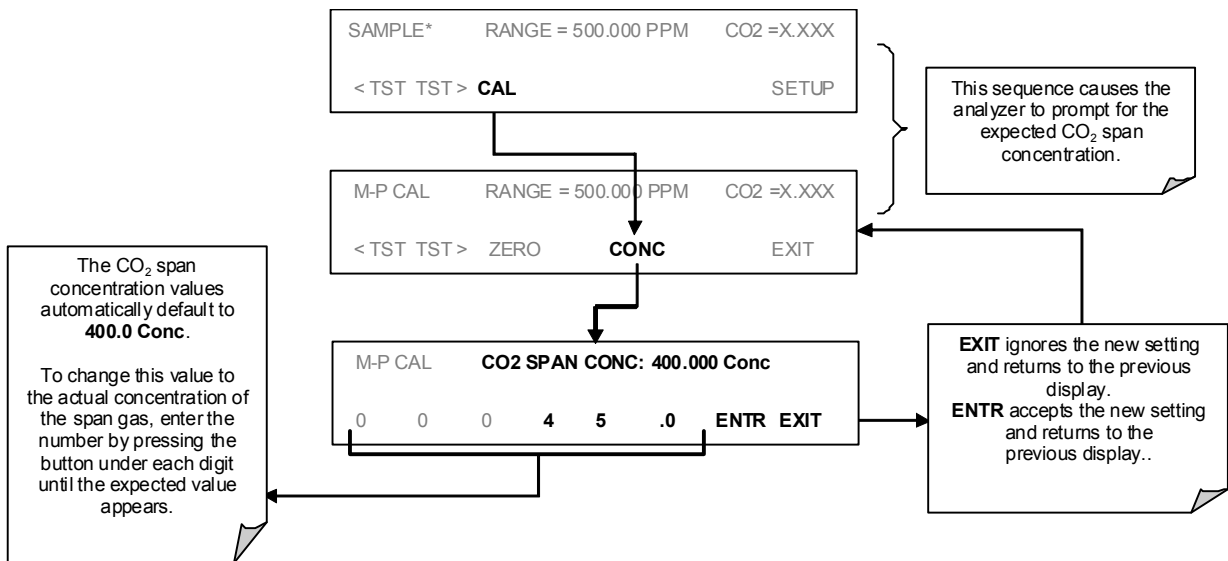

Figure 5-2: Pneumatic Connections–Basic Configuration–Using Gas Dilution Calibrator

STEP TWO: Set the expected CO₂ Span Gas concentration:



NOTE

For this Initial Calibration it is important to independently verify the **PRECISE CO₂ Concentration Value of the SPAN gas.**

If the source of the Span Gas is from a Calibrated Bottle, use the exact concentration value printed on the bottle.

STEP THREE: Perform the Zero/Span Calibration Procedure:

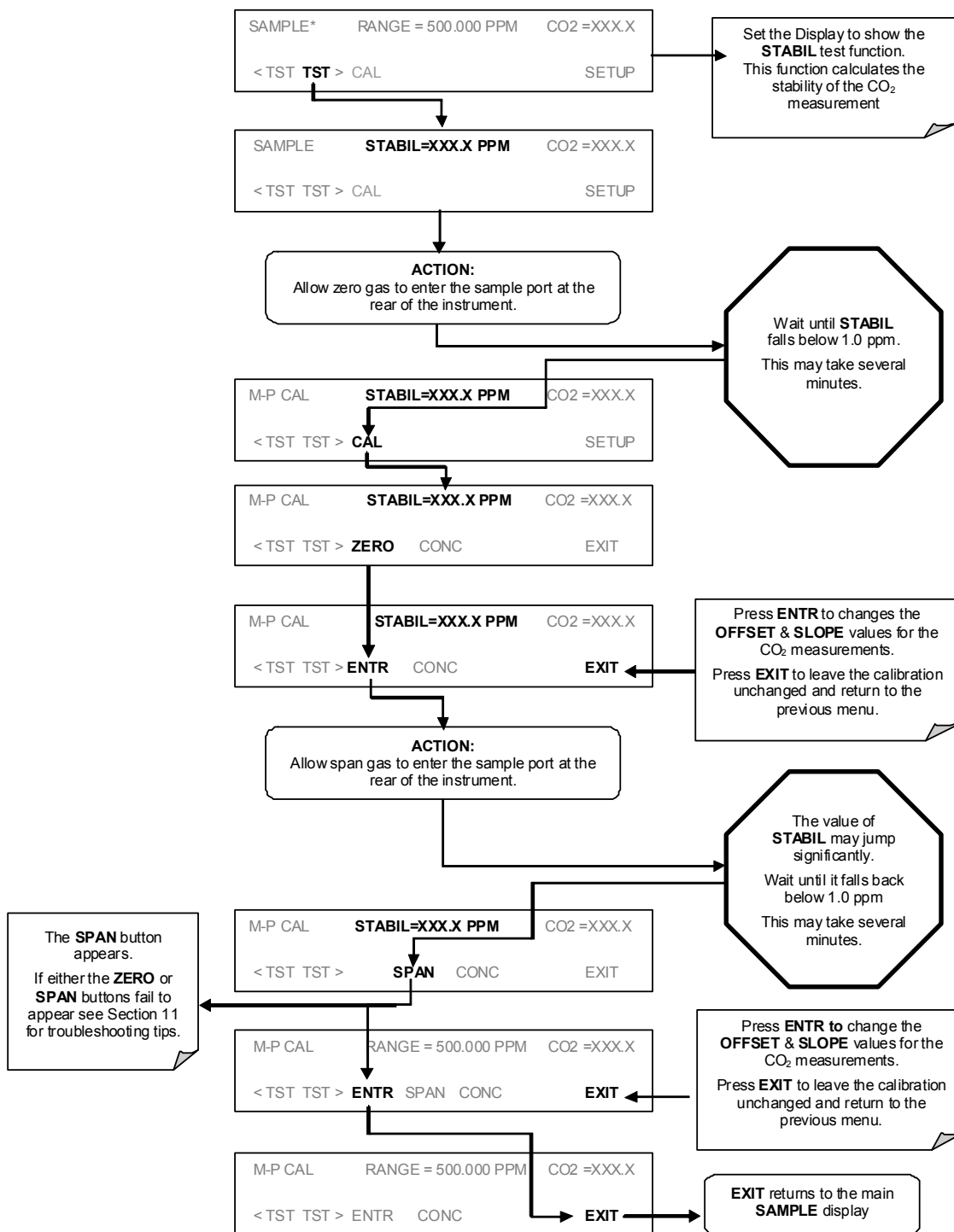

If the **ZERO** or **SPAN** buttons are not displayed, this means that the measurement made during that part of the procedure is too far out of the allowable range to do allow a reliable calibration. The reason for this must be determined before the analyzer can be calibrated. See Section 8 for troubleshooting tips.

5.3. MANUAL CALIBRATION CHECKS

Informal calibration checks, which only evaluate but do not alter the analyzer's response curve, are recommended as a regular maintenance item and in order to monitor the analyzer's performance. To carry out a calibration check rather than a full calibration, follow these steps.

STEP ONE: Connect the sources of zero air and span gas as shown in Figures 7.1 or 7.2.

STEP TWO: Perform the zero/span calibration check procedure:

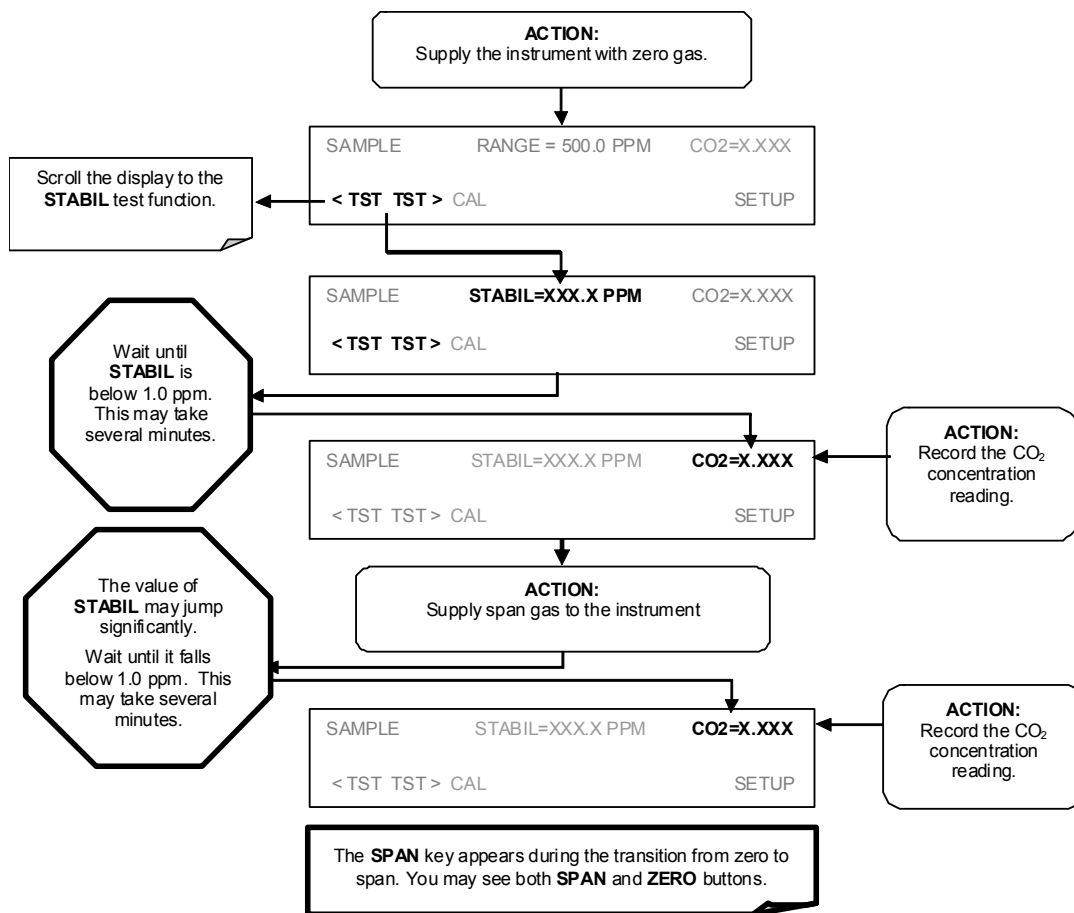

5.4. MANUAL CALIBRATION WITH ZERO/SPAN VALVES

There are four different zero/span valve option configurations (see Figure 5-3 through Figure 5-6). They all operate identically, differing only in the method used to supply calibration gas to the Analyzer.

STEP ONE: Connect the sources of Zero Air and Span Gas as shown below.

Figure 5-3 through Figure 5-6 show the proper pneumatic connections for T360s with various optional internal valve sets installed.

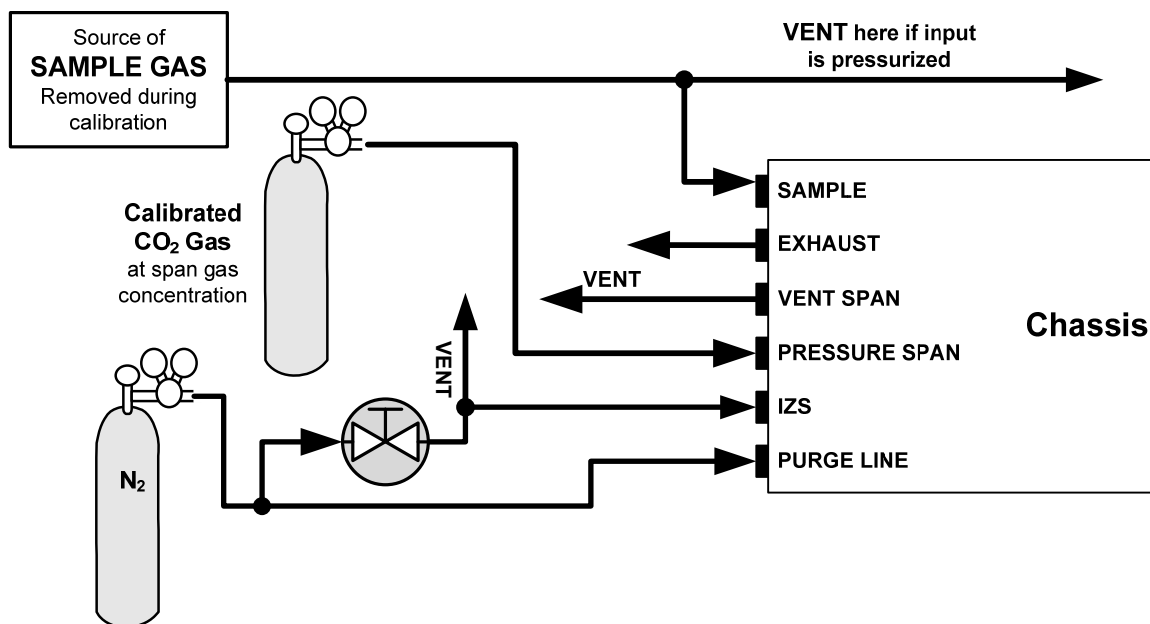

Figure 5-3: Pneumatic Connections – Ambient Zero/Pressurized Span Valves

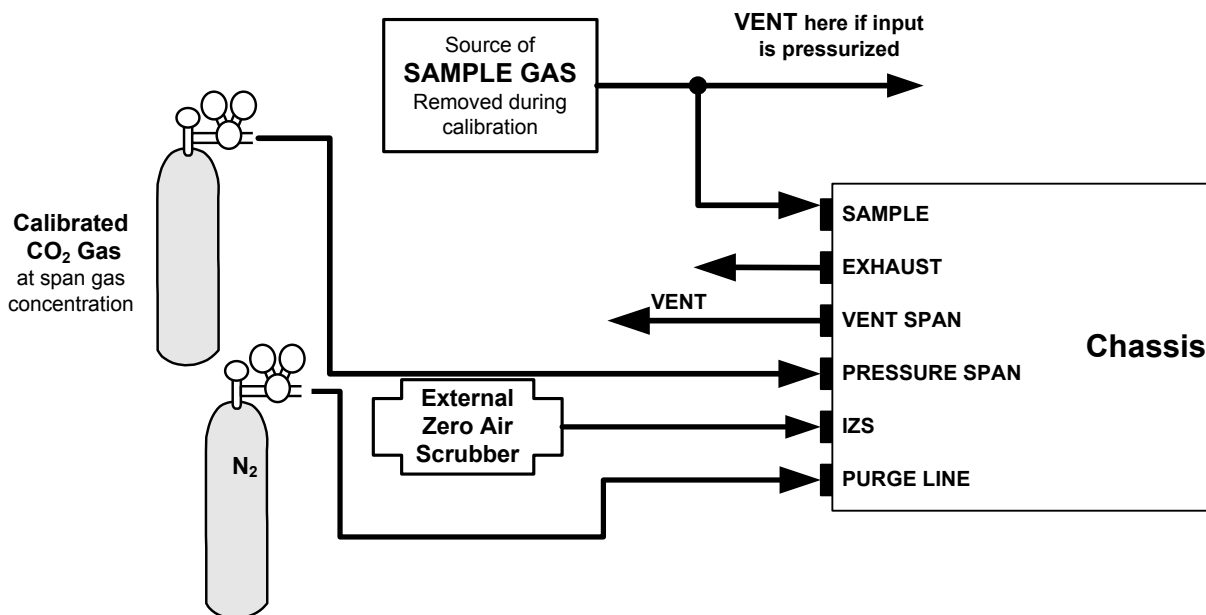

Figure 5-4: Pneumatic Connections – Ambient Zero/Pressurized Span Valves and External Zero Air Scrubber

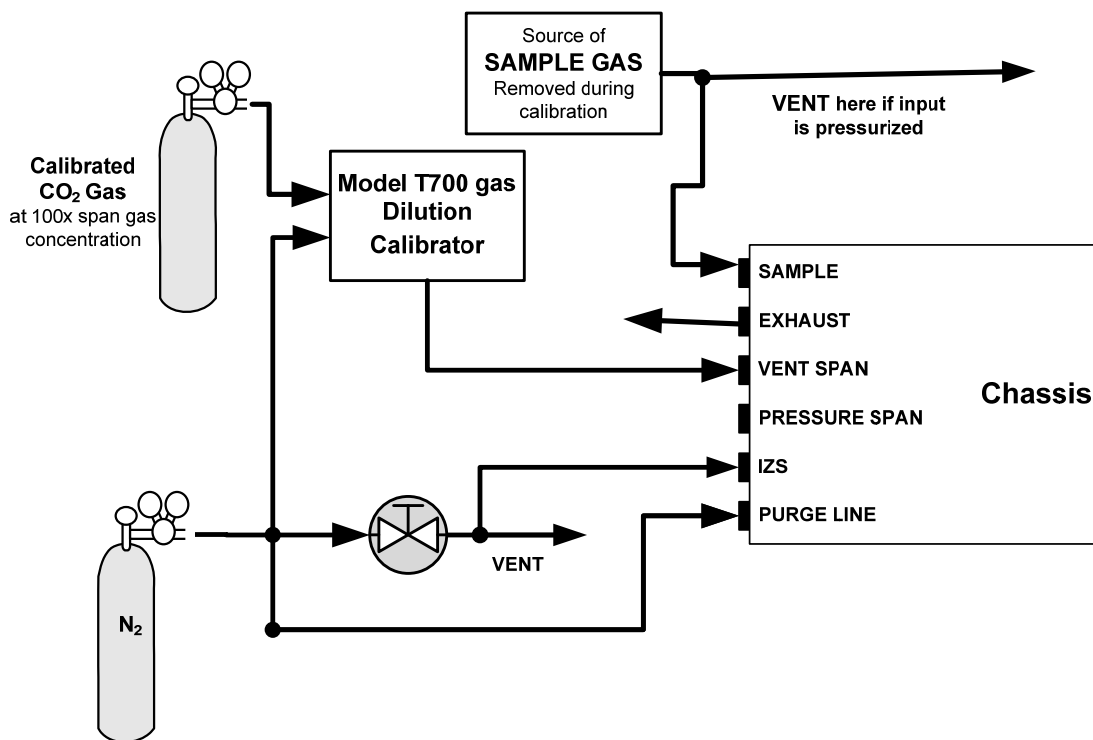

Figure 5-5: Pneumatic Connections – Ambient Zero/Ambient Span Valves

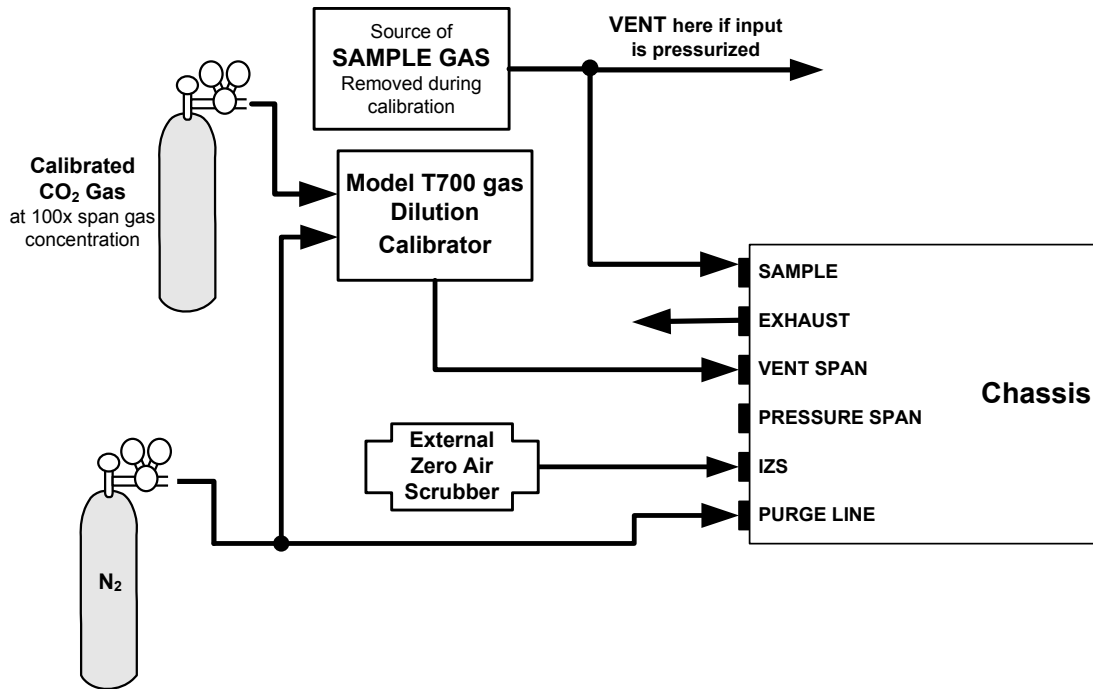
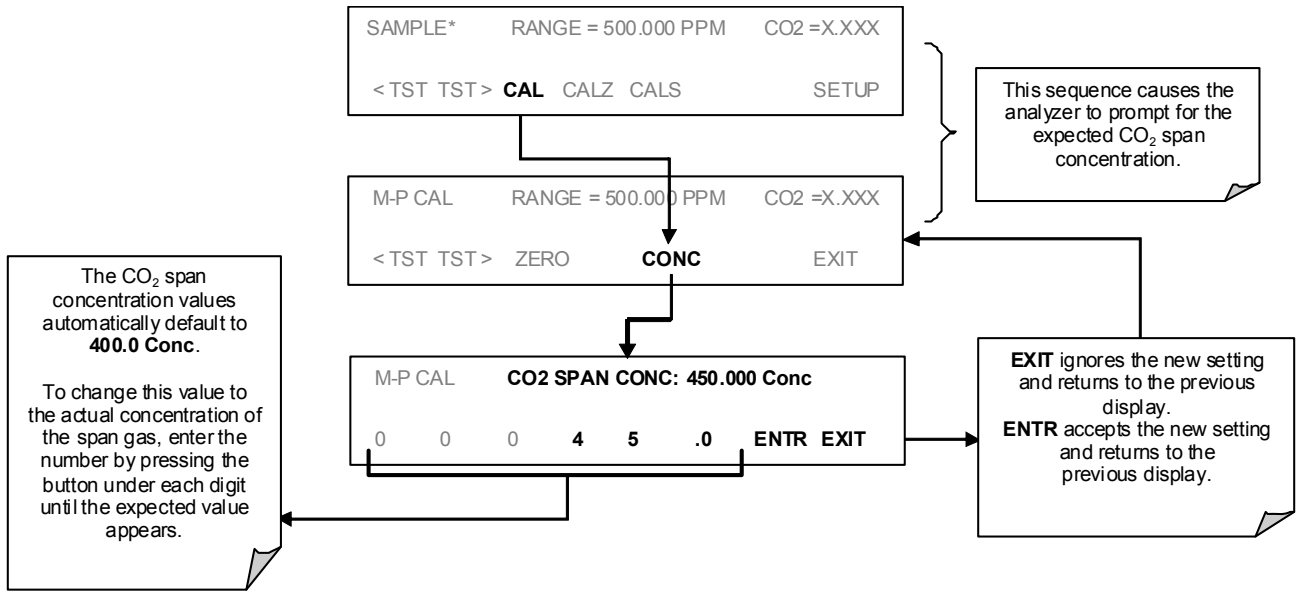

Figure 5-6: Pneumatic Connections – Ambient Zero/Ambient Span Valves with External Zero Air Scrubber

STEP TWO: Set the expected CO₂ Span Gas concentration:



NOTE

For this Initial Calibration it is important to independently verify the PRECISE CO₂ Concentration Value of the SPAN gas.

If the source of the Span Gas is from a Calibrated Bottle, use the exact concentration value printed on the bottle.

STEP THREE: Perform the zero/span calibration. Zero and span checks using the zero/span valve option are similar to that described in Section 5.5, except that zero air and span gas is supplied to the analyzer through the zero/span valves rather than through the sample inlet port.

The zero and cal operations are initiated directly and independently with dedicated buttons (CALZ & CALS).

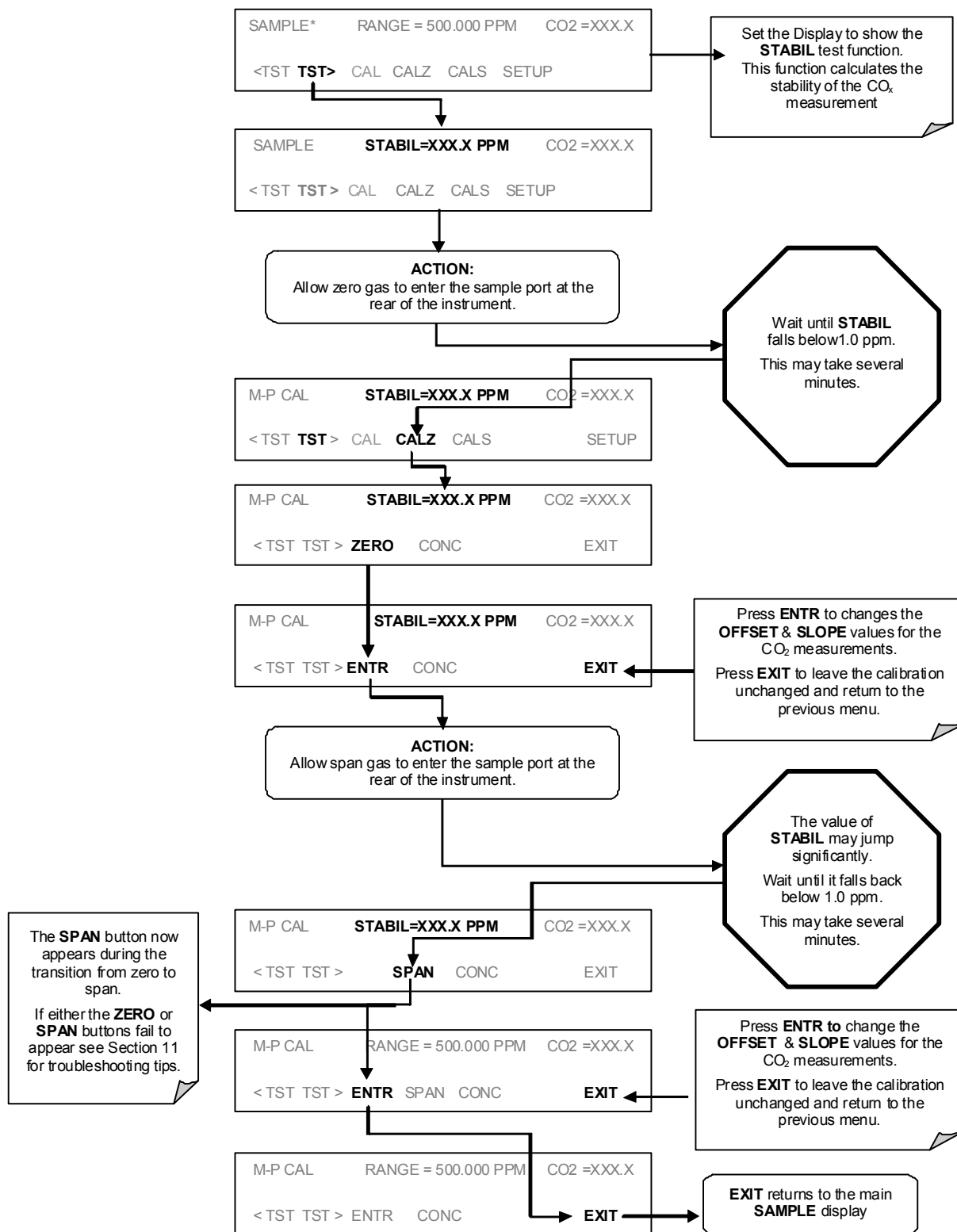

5.5. MANUAL CALIBRATION CHECKS WITH ZERO/SPAN VALVES

Zero and span checks using the various zero/span valve options available for the T360 are similar to that described in Section 5.3, except that the zero and calibration operations are initiated directly and independently with dedicated buttons CALZ and CALS.

To perform a manual calibration check of an analyzer with a valve option installed, use the following method.

STEP ONE: Connect the sources of Zero Air and Span Gas as shown in Figure 5-3 through Figure 5-6.

STEP TWO: Perform the zero/span check.

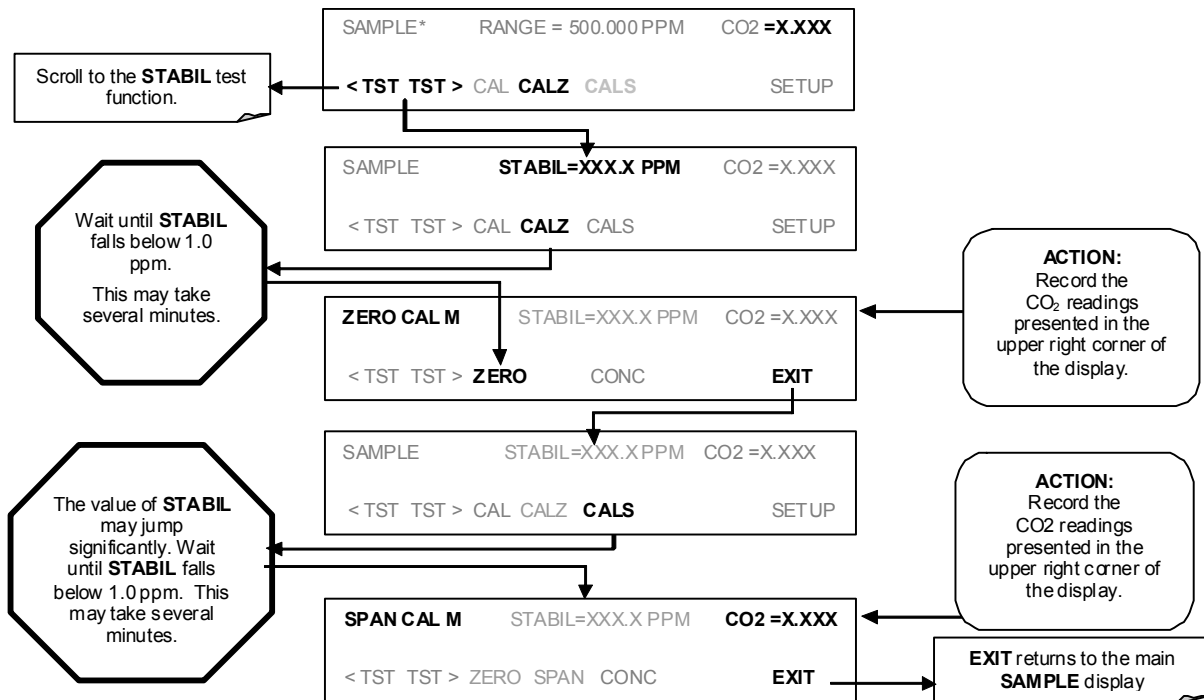

5.5.1. Zero/Span Calibration on Auto Range or Dual Ranges

If the analyzer is being operated in dual range mode or auto range mode, then the high and low ranges must be independently calibrated.

When the analyzer is in either dual or auto range modes the user must run a separate calibration procedure for each range. After pressing the **CAL**, **CALZ** or **CALS** buttons the user is prompted for the range that is to be calibrated as seen in the **CALZ** example below:

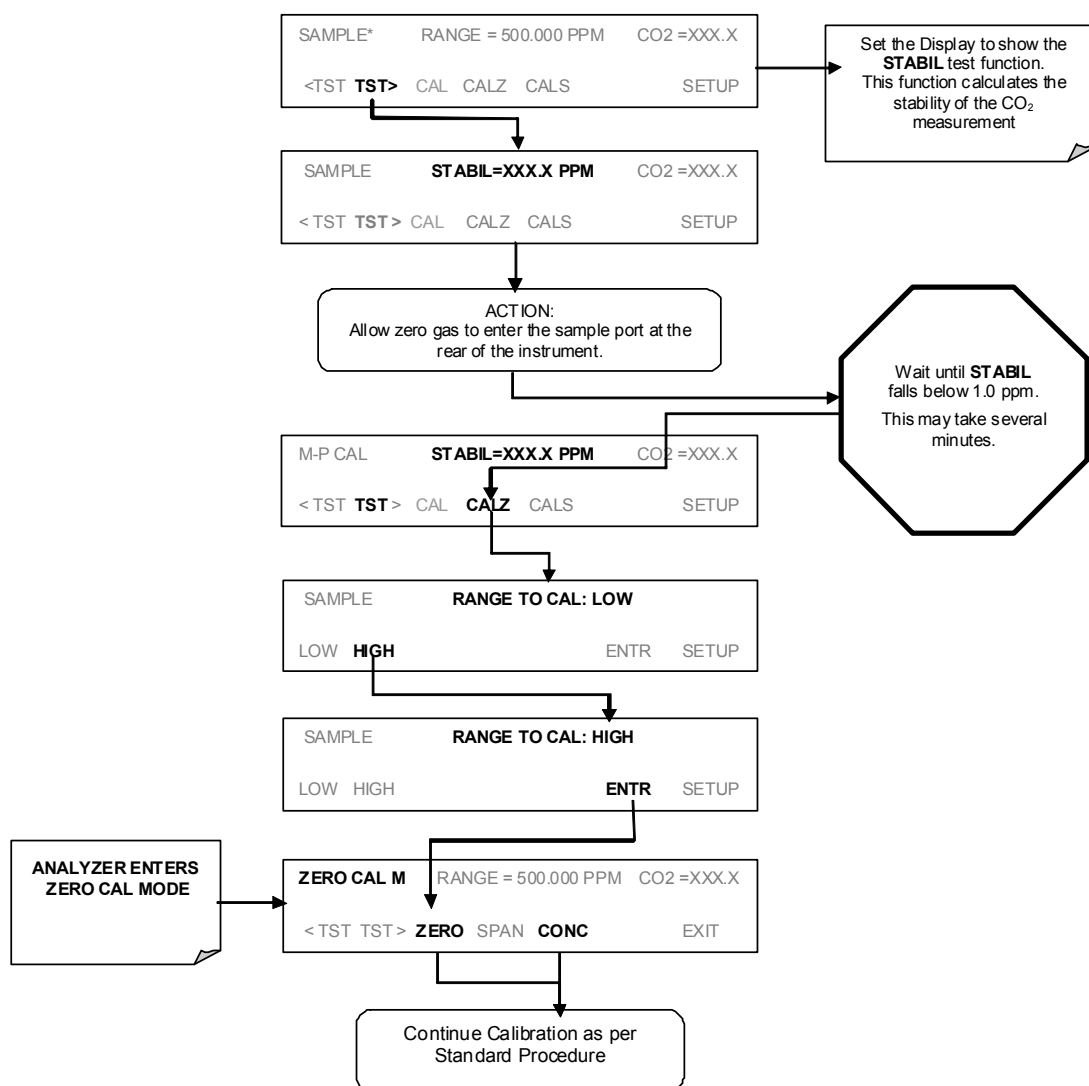

Once this selection is made, the calibration procedure continues as previously described in Section 5.2. The other range may be calibrated by starting over from the main **SAMPLE** display.

5.5.2. Use of Zero/Span Valves with Remote Contact Closure

Contact closures for controlling calibration are located on the rear panel CONTROL IN connector. Instructions for setup and use of these contacts are found in Section 4.15.1.2. When the contacts are closed for at least 5 seconds, the instrument switches into zero or span mode. The remote calibration contact closures may be activated in any order. It is recommended that contact closures remain closed for at least 10 minutes to establish a reliable reading.

The instrument will stay in the selected mode for as long as the contacts remain closed. If calibration is enabled, the T360 will re-calibrate when the contact is opened, then go into SAMPLE mode. If calibration is disabled, the instrument will return to SAMPLE mode, leaving the calibration unchanged.

5.6. AUTOMATIC ZERO/SPAN CAL/CHECK (AUTOCAL)

The AutoCal system allows unattended periodic operation of the ZERO/SPAN valve options by using the T360's internal time of day clock. AutoCal operates by executing SEQUENCES programmed by the user to initiate the various calibration modes of the analyzer and open and close valves appropriately. It is possible to program and run up to 3 separate sequences (SEQ1, SEQ2 and SEQ3). Each sequence can operate in one of 3 Modes, or be disabled.

Table 5-1: AUTOCAL Modes

MODE NAME	ACTION
DISABLED	Disables the Sequence
ZERO	Causes the Sequence to perform a zero calibration/check
ZERO-SPAN	Causes the Sequence to perform a zero and span concentration calibration/check
SPAN	Causes the Sequence to perform a span concentration calibration/check

For each mode there are seven parameters that control operational details of the SEQUENCE. They are:

Table 5-2: AutoCal ATTRIBUTE Setup Parameters

ATTRIBUTE NAME	ACTION
TIMER ENABLED	Turns on the Sequence timer
STARTING DATE	Sequence will operate after Starting Date
STARTING TIME	Time of day sequence will run
DELTA DAYS	Number of days to skip between each Seq. execution
DELTA TIME	Number of hours later each "Delta Days" Seq is to be run
DURATION	Number of minutes the sequence operates
CALIBRATE	Enable to do a calibration – Disable to do a cal check only

The following example sets Sequence #2 to do a Zero-Span Calibration every other day starting at 1 am on September 4, 2001, lasting 15 minutes, without calibration. This will start ½ hour later each iteration.

MODE AND ATTRIBUTE	VALUE	COMMENT
Sequence	2	Define Sequence #2
Mode	ZERO-SPAN	Select Zero and Span Mode
Timer Enable	ON	Enable the timer
Starting Date	Sept. 4, 2001	Start after Sept 4, 2001
Starting Time	01:00	First Span starts at 1:00AM
Delta Days	2	Do Sequence #2 every other day
Delta Time	00:30	Do Sequence #2 ½ hr later each day
Duration	15.0	Operate Span valve for 15 min
Calibrate	NO	Do not calibrate at end of Sequence

NOTES

- The programmed STARTING_TIME must be a minimum of 5 minutes later than The real time clock (see Section 4.10 for setting real time clock).
- Avoid setting two or more sequences at the same time of the day. Any new sequence which is initiated whether from a timer, the COM ports, or the contact closure inputs will override any sequence which is in progress.
- If at any time an illegal entry is selected (Example: Delta Days > 367) the ENTR button will disappear from the display.

To program the Sequence:

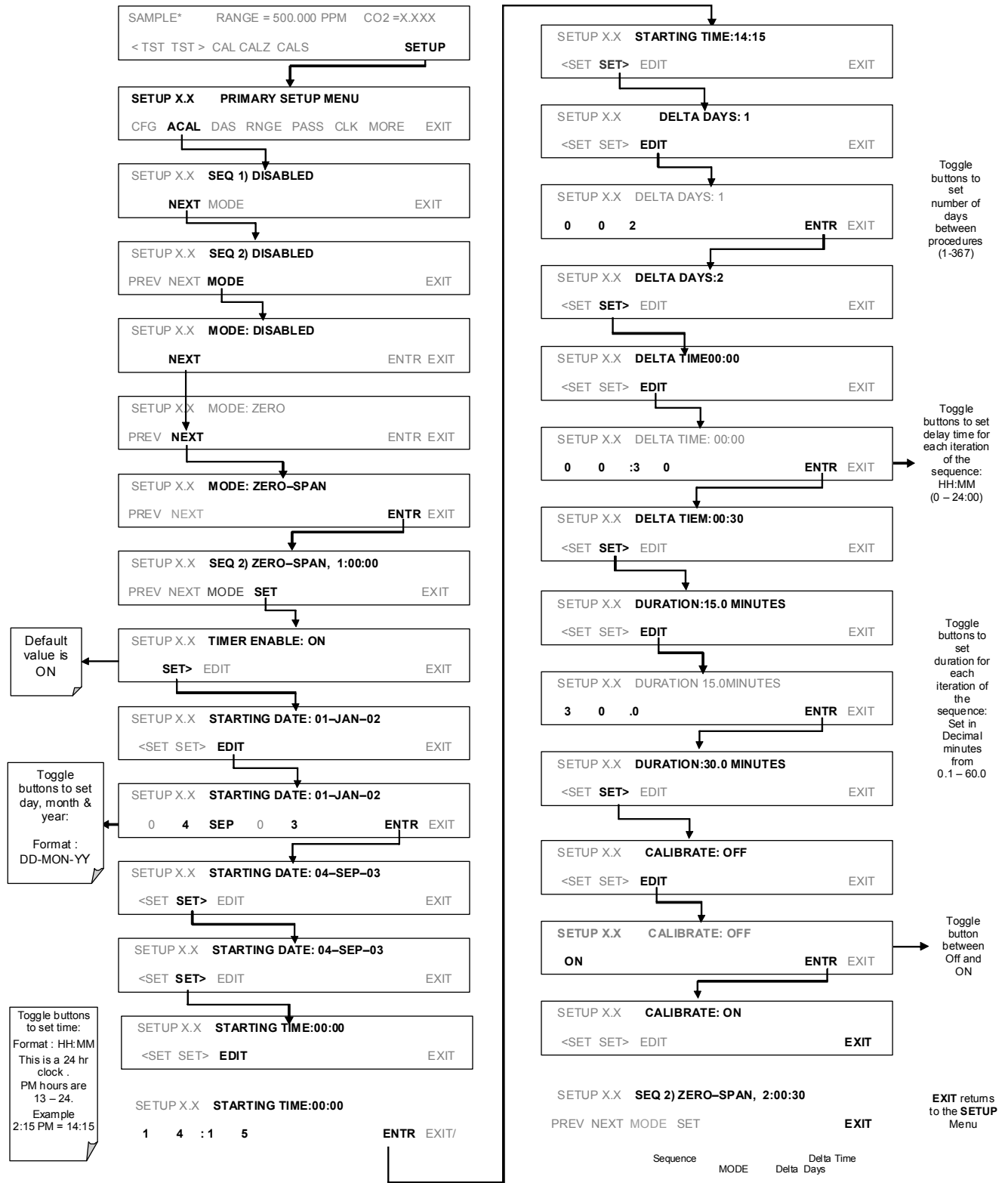

5.6.1. AutoCal with Auto or Dual Reporting Ranges Modes Selected

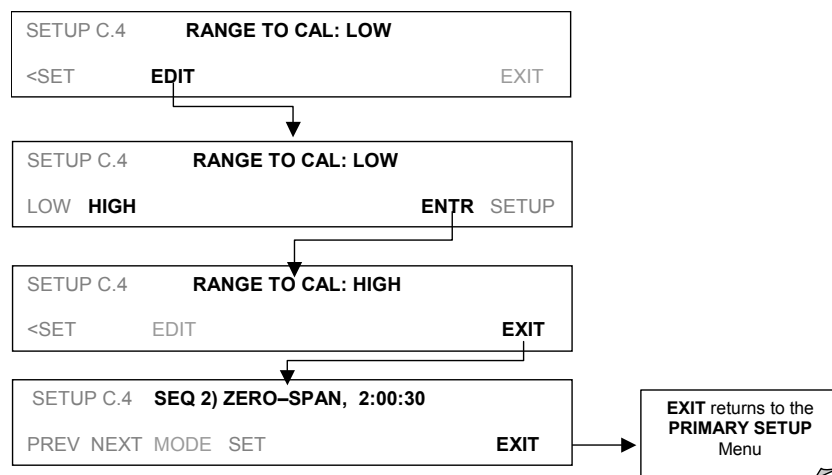

NOTE

In order to automatically calibrate both the HIGH and LOW ranges, you must set up a separate sequence for each.

5.7. CALIBRATION QUALITY

After completing one of the calibration procedures described above, it is important to evaluate the analyzer's calibration SLOPE and OFFSET parameters. These values describe the linear response curve of the analyzer. The values for these terms, both individually and relative to each other, indicate the quality of the calibration. To perform this quality evaluation, you will need to record the values of both test functions (Section 4.2.1 or Appendix A-3), all of which are automatically stored in the DAS channel CALDAT for data analysis, documentation and archival.

Make sure that these parameters are within the limits listed in Table 5-3 and frequently compare them to those values on the *Final Test and Checkout Sheet* that came attached to your manual, which should not be significantly different. If they are, refer to the troubleshooting Section 8.

Table 5-3 : Calibration Data Quality Evaluation

FUNCTION	MINIMUM VALUE	OPTIMUM VALUE	MAXIMUM VALUE
SLOPE	0.700	1.000	1.300
OFFS	-0.500	0.000	0.500

These values should not be significantly different from the values recorded on the Teledyne API *Final Test and Validation Data* sheet that was shipped with your instrument. If they are, refer to the troubleshooting Section 8.

The default DAS configuration records all calibration values in channel **CALDAT** as well as all calibration check (zero and span) values in its internal memory. Up to 200 data points are stored for up 4 years of data (on weekly calibration checks) and a lifetime history of monthly calibrations. Review these data to see if the zero and span responses change over time. These channels also store the STABIL value (standard deviation of CO concentration) to evaluate if the analyzer response has properly leveled off during the calibration procedure. Finally, the CALDAT channel also stores the converter efficiency for review and documentation.

If your instrument has an O₂ sensor option installed, that should be calibrated as well.

6. MAINTENANCE SCHEDULE AND PROCEDURES

Predictive diagnostic functions, including data acquisition records, failure warnings and test functions built into the analyzer, allow the user to determine when repairs are necessary without performing painstaking preventative maintenance procedures. There are, however, a minimal number of simple procedures that when performed regularly will ensure that the analyzer continues to operate accurately and reliably over its lifetime. Repairs and troubleshooting are covered in Section 8 of this manual.

6.1. MAINTENANCE SCHEDULE

Table 6-1 shows a typical maintenance schedule for the analyzer. Please note that in certain environments (i.e. dusty, very high ambient pollutant levels) some maintenance procedures may need to be performed more often than shown.

NOTE

A Span and Zero Calibration Check (see CAL CHECK REQ'D Column of Table 6-1) must be performed following certain of the maintenance procedure listed below.

See Sections 5.3, 5.5, and 5.6 for instructions on performing checks.



CAUTION

Risk of electrical shock. Disconnect power before performing any of the following operations that require entry into the interior of the analyzer.



NOTE

The operations outlined in this section are to be performed by qualified maintenance personnel only.

This page intentionally left blank.

Table 6-1: T360 Maintenance Schedule

ITEM	ACTION	FREQ	CAL CHECK REQ'D.	MANUAL	DATE PERFORMED								
Particulate Filter	Replace	Weekly or as needed	Yes										
Verify Test Functions	Record and analyze	Weekly or after any Maintenance or Repair	No										
Pump Diaphragm	Replace	Annually	Yes										
Perform Flow Check	Check Flow	Annually	No										
Perform Leak Check	Verify Leak Tight	Annually or after any Maintenance or Repair	No										
Pneumatic lines	Examine and clean	As needed	Yes if cleaned										
Cleaning	Clean	As needed	Only if cover remv'd										

Table 6-2: T360 Test Function Record

FUNCTION	OPERATING MODE*	DATE RECORDED											
STABILITY	ZERO CAL												
CO2 MEAS	ZERO CAL												
MR RATIO	Zero CAL												
	SPAN CAL												
PRES	SAMPLE												
PHT DRIVE	SAMPLE After Warm-up												
SLOPE	SPAN CAL												
OFFSET	ZERO CAL												

6.2. PREDICTING FAILURES USING THE TEST FUNCTIONS

The Test Functions can be used to predict failures by looking at how their values change over time. Initially it may be useful to compare the state of these Test Functions to the values recorded on the printed record of the final calibration performed on your instrument at the factory, p/n 04307. Table 6-3 can be used as a basis for taking action as these values change with time. The internal data acquisition system (DAS) is a convenient way to record and track these changes. Use APICOM to download and review this data from a remote location.

Table 6-3: Predictive Uses for Test Functions

FUNCTION	CONDITION	BEHAVIOR	INTERPRETATION
STABILITY	Zero Cal	Increasing	Pneumatic Leaks – instrument & sample system Detector deteriorating
CO2 MEAS	Zero Cal	Decreasing	Source Aging Detector deteriorating Optics getting dirty or contaminated
MR RATIO	Zero Cal	Increasing	Source Aging Detector deteriorating Contaminated zero gas (H2O)
		Decreasing	Source Aging Detector deteriorating GFC Wheel Leaking Pneumatic Leaks Contaminated zero gas (CO ₂)
	Span Cal	Increasing	Source Aging Pneumatic Leaks – instrument & sample system Calibration system deteriorating
		Decreasing	Source Aging GFC Wheel Leaking Calibration system deteriorating
PRES	Sample	Increasing > 1"	Pneumatic Leak between sample inlet and Sample Cell Change in sampling manifold
		Decreasing > 1"	Dirty particulate filter Pneumatic obstruction between sample inlet and Sample Cell Obstruction in sampling manifold
PHT DRIVE	Any, but with Bench Temp at 48°C	Increasing	Mechanical Connection between IR-Detector and Sample Cell deteriorating IR-Photodetector deteriorating
OFFSET	Zero Cal	Increasing	See MR Ratio - Zero Cal Decreasing above
		Decreasing	See MR Ratio - Zero Cal Increasing above
SLOPE	Span Cal	Increasing	See MR Ratio - Span Cal Decreasing above
		Decreasing	See MR Ratio – Span Cal Increasing above

6.3. MAINTENANCE PROCEDURES

The following procedures are to be performed periodically as part of the standard maintenance of the Model T360.

6.3.1. Replacing the Sample Particulate Filter

The particulate filter should be inspected often for signs of plugging or contamination. We recommend that when you change the filter, handle it and the wetted surfaces of the filter housing as little as possible. Do not touch any part of the housing, filter element, PTFE retaining ring, glass cover and the o-ring.

To change the filter:

1. Turn OFF the analyzer to prevent drawing debris into the instrument.
2. Open the T360's hinged front panel and unscrew the knurled retaining ring on the filter assembly.

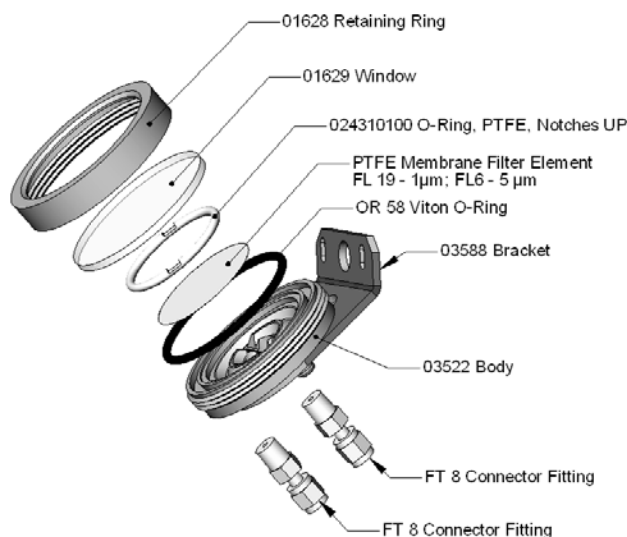

Figure 6-1: Sample Particulate Filter Assembly

3. Carefully remove the retaining ring, PTFE o-ring, glass filter cover and filter element.
4. Replace the filter, being careful that the element is fully seated and centered in the bottom of the holder.
5. Re-install the PTFE o-ring with the notches up, install the glass cover, then screw on the retaining ring and hand tighten. Inspect the seal between the edge of filter and the o-ring to assure a proper seal.
6. Restart the Analyzer.

6.3.2. Rebuilding the Sample Pump

The diaphragm in the sample pump periodically wears out and must be replaced. A sample rebuild kit is available – see Appendix B of this manual for the part number of the pump rebuild kit. Instructions and diagrams are included with the kit.

Always perform a Flow and Leak Check after rebuilding the Sample Pump.

6.3.3. Performing Leak Checks

Leaks are the most common cause of analyzer malfunction; Section 6.3.3.1 presents a simple leak check procedure. Section 6.3.3.2 details a more thorough procedure.

6.3.3.1. VACUUM LEAK CHECK AND PUMP CHECK

This method is easy and fast. It detects, but does not locate most leaks; it also verifies that the sample pump is in good condition.

1. Turn the analyzer ON, and allow enough time for flows to stabilize.
2. Cap the sample inlet port.
3. After several minutes, when the pressures have stabilized, note the following. In the **TEST** menu, note the **SAMPLE PRESSURE** reading.
4. If the reading is < 10 in-Hg, the pump is in good condition and there are no large leaks.
5. Check the sample gas flow. If the flow is <10 cm³/min and stable, there are no large leaks in the instrument's pneumatics.

6.3.3.2. PRESSURE LEAK CHECK

If you can't locate the leak by the above procedure, use the following procedure. Obtain a leak checker similar to the Teledyne API part number 01960, which contains a small pump, shut-off valve, and pressure gauge. Alternatively, a convenient source of low-pressure gas is a tank of span gas, with the two-stage regulator adjusted to less than 15 psi with a shutoff valve and pressure gauge.



CAUTION

Do not use bubble solution with vacuum applied to the analyzer. The solution may contaminate the instrument. Do not exceed 15 PSIG pressure.

1. Turn OFF power to the instrument.
2. Install a leak checker or tank of gas as described above on the sample inlet at the rear panel.
3. Remove the instrument cover and locate the inlet side of the sample pump. Remove the flow assembly from the pump and plug it with the appropriate gas-tight fitting.

4. Pressurize the instrument with the leak checker, allowing enough time to fully pressurize the instrument through the critical flow orifice. Check each fitting with soap bubble solution, looking for bubbles. Once the fittings have been wetted with soap solution, do not re-apply vacuum, as it will suck soap solution into the instrument and contaminate it. Do not exceed 15 psi pressure.
5. If the instrument has one of the zero and span valve options, the normally closed ports on each valve should also be separately checked. Connect the leak checker to the normally closed ports and check with soap bubble solution.
6. Once the leak has been located and repaired, use a clean, absorbent, and lint-free material to remove any residual soap solution from the instrument interior. The leak-down rate should be < 1 in-Hg (0.4 psi) in 5 minutes after the pressure is shut off.

6.3.4. Performing a Sample Flow Check



CAUTION

Always use a separate calibrated flow meter capable of measuring flows in the 0 – 1000 cc/min range to measure the gas flow rate through the analyzer.

DO NOT use the built in flow measurement viewable from the Front Panel of the instrument. This measurement is only for detecting major flow interruptions such as clogged or plugged gas lines.

See Figure 3-4 for SAMPLE port location.

1. Attach the Flow Meter to the sample inlet port on the rear panel. Ensure that the inlet to the Flow Meter is at atmospheric f.
2. Sample flow should be 800 cc/min \pm 10%.
3. Once an accurate measurement has been recorded by the method described above, adjust the analyzer's internal flow sensors (see Section 4.13.8)

Low flows indicate blockage somewhere in the pneumatic pathway, typically a plugged sintered filter or critical flow orifice in one of the analyzer's flow control assemblies. High flows indicate leaks downstream of the Flow Control Assembly.

6.3.5. Cleaning the Optical Bench

The T360 sensor assembly and optical bench is complex and delicate. Disassembly and cleaning is not recommended. Please check with the factory before disassembling the optical bench.

6.3.6. Cleaning the Chassis

If necessary, the exterior surfaces of the T360 can be cleaned with a clean damp cloth. Do not submerge any part of the instrument in water or cleaning solution.

7. PRINCIPLES OF OPERATION

The Model T360 Gas Filter Correlation Carbon Dioxide Analyzer is a microprocessor-controlled analyzer that determines the concentration of carbon dioxide (CO₂) in a sample gas drawn through the instrument. It requires that sample and calibration gasses be supplied at ambient atmospheric pressure in order to establish a stable gas flow through the sample chamber where the gases ability to absorb infrared radiation is measured.

Calibration of the instrument is performed in software and does not require physical adjustments to the instrument. During calibration the microprocessor measures the current state of the IR Sensor output and various other physical parameters of the instrument and stores them in memory.

The microprocessor uses these calibration values, the IR absorption measurements made on the sample gas along with data regarding the current temperature and pressure of the gas to calculate a final CO₂ concentration.

This concentration value and the original information from which it was calculated are stored in one of the unit's internal data acquisition system (DAS - Section 4.7), as well as reported to the user via a vacuum fluorescent display or a variety of digital and analog signal outputs.

7.1. MEASUREMENT METHOD

7.1.1. Beer's Law

The basic principle by which the analyzer works is called Beer's Law. It defines the how light of a specific wavelength is absorbed by a particular gas molecule over a certain distance. The mathematical relationship between these three parameters is:

$$I = I_0 e^{-\alpha Lc}$$

Where:

I₀ is the intensity of the light if there was no absorption.

I is the intensity with absorption.

L is the absorption path, or the distance the light travels as it is being absorbed.

C is the concentration of the absorbing gas. In the case of the Model T360, carbon dioxide (CO₂).

α is the absorption coefficient that tells how well CO₂ absorbs light at the specific wavelength of interest.

7.1.2. Measurement Fundamentals

In the most basic terms, the Model T360 uses a high energy heated element to generate a beam of broad-band IR light with a known intensity (measured during Instrument calibration). This beam is directed through multi-pass cell filled with sample gas. The sample cell uses mirrors at each end to reflect the IR beam back and forth through the sample gas to generate a 2.5 meter absorption path (see Figure 7-1). This length was chosen to give the analyzer maximum sensitivity to fluctuations in CO₂ density.

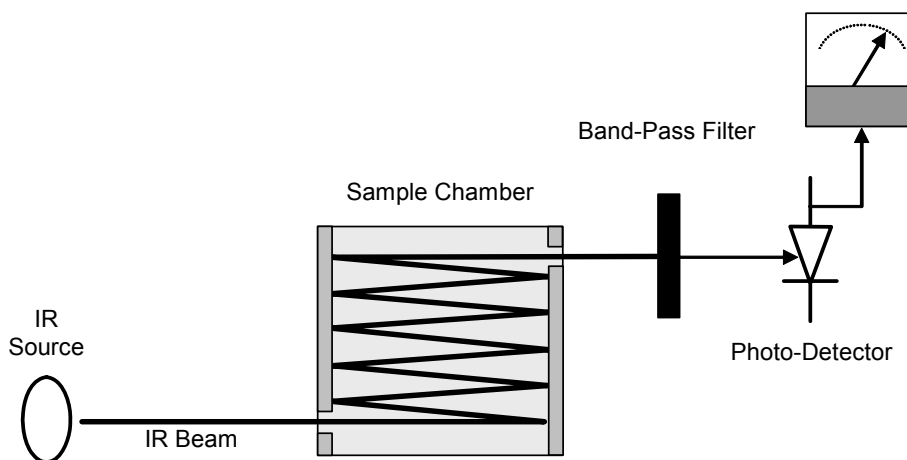

Figure 7-1: Measurement Fundamentals

Upon exiting the sample cell, the beam shines through a band-pass filter that allows only light at a wavelength of 4.3 μm to pass. Finally, the beam strikes a solid-state photo-detector that converts the light signal into a modulated voltage signal representing the attenuated intensity of the beam.

7.1.3. Gas Filter Correlation

Unfortunately, water vapor absorbs light at 4.3 μm too. To overcome the interfering effects of water vapor the Model T360 adds another component to the IR light path called a gas filter correlation (GFC) wheel (see Figure 7-2).

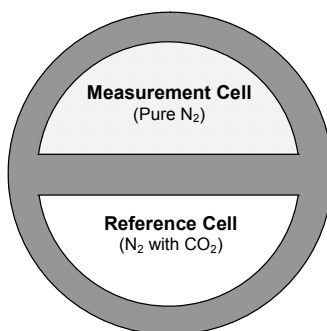

Figure 7-2: GFC Wheel

7.1.3.1. THE GFC WHEEL

A GFC wheel is a metallic wheel into which two chambers are carved. The chambers are sealed on both sides with material transparent to $4.3\ \mu\text{m}$ IR radiation creating two airtight cavities. Each cavity is filled with specially composed gases. One cell is filled with pure N_2 (the measure cell). The other is filled with a combination of N_2 and a high concentration of CO_2 (the reference cell).

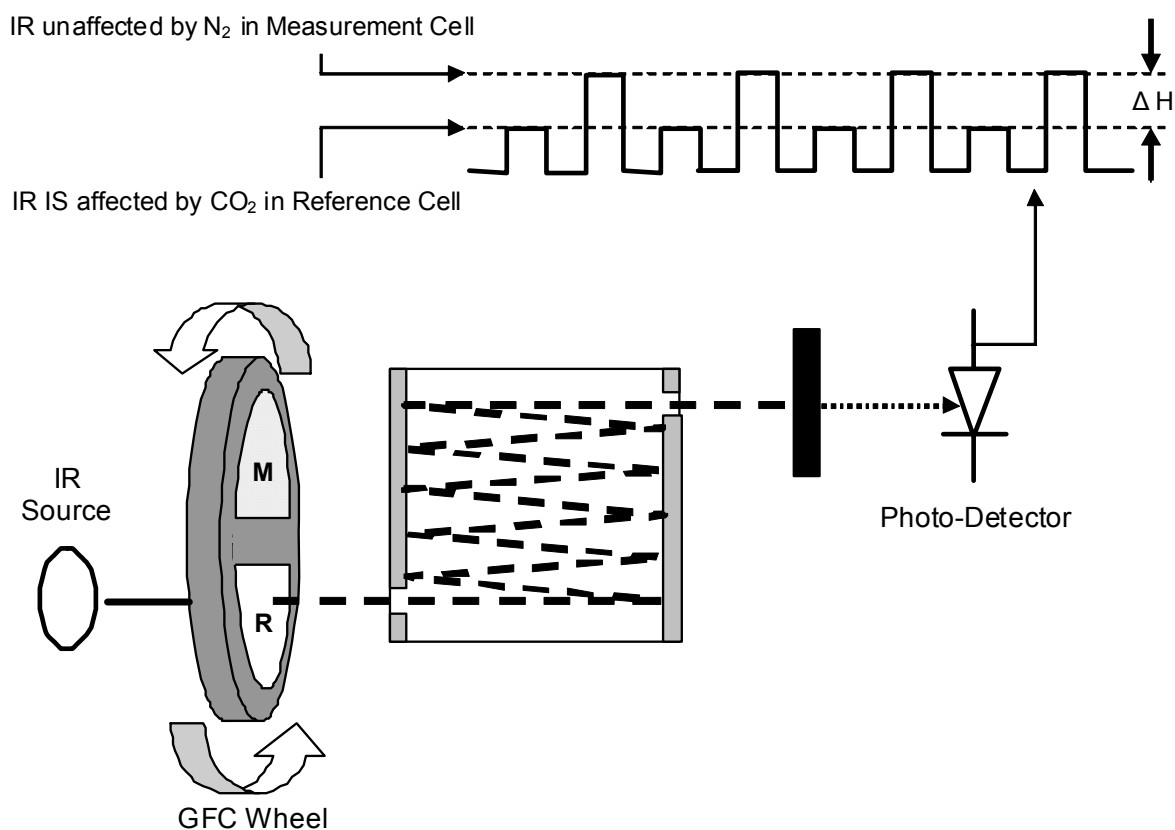

Figure 7-3: Measurement Fundamentals with GFC Wheel

As the GFC wheel spins, the IR light alternately passes through the two cavities. When the beam is exposed to the reference cell, the CO_2 in the gas filter wheel strips the beam of most of the IR at $4.3\ \mu\text{m}$. When the light beam is exposed to the measurement cell, the N_2 in the filter wheel does not absorb IR light. This results in a fluctuation in the intensity of the IR light striking the photo-detector (Figure 7-3) that results in the output of the detector resembling a square wave such as that shown in Figure 7-4.

7.1.3.2. THE MEASURE/REFERENCE RATIO

The Model T360 determines the amount of CO₂ in the sample chamber by computing the ratio between the peak of the measurement pulse (**CO₂ MEAS**) and the peak of the reference pulse (**CO₂ REF**).

If no gases exist in the sample chamber that absorb light at 4.3 μ m, the high concentration of CO₂ in the gas mixture of the reference cell will attenuate the intensity of the IR beam by 60% giving a M/R ratio of approximately 2.4:1.

Adding CO₂ to the sample chamber causes the peaks corresponding to both cells to be attenuated by a further percentage. Since the intensity of the light passing through the measurement cell is greater, the effect of this additional attenuation is greater. This causes **CO₂ MEAS** to be more sensitive to the presence of CO₂ in the sample chamber than **CO₂ REF** and the ratio between them (M/R) to move closer to 1:1 as the concentration of CO₂ in the sample chamber increases.

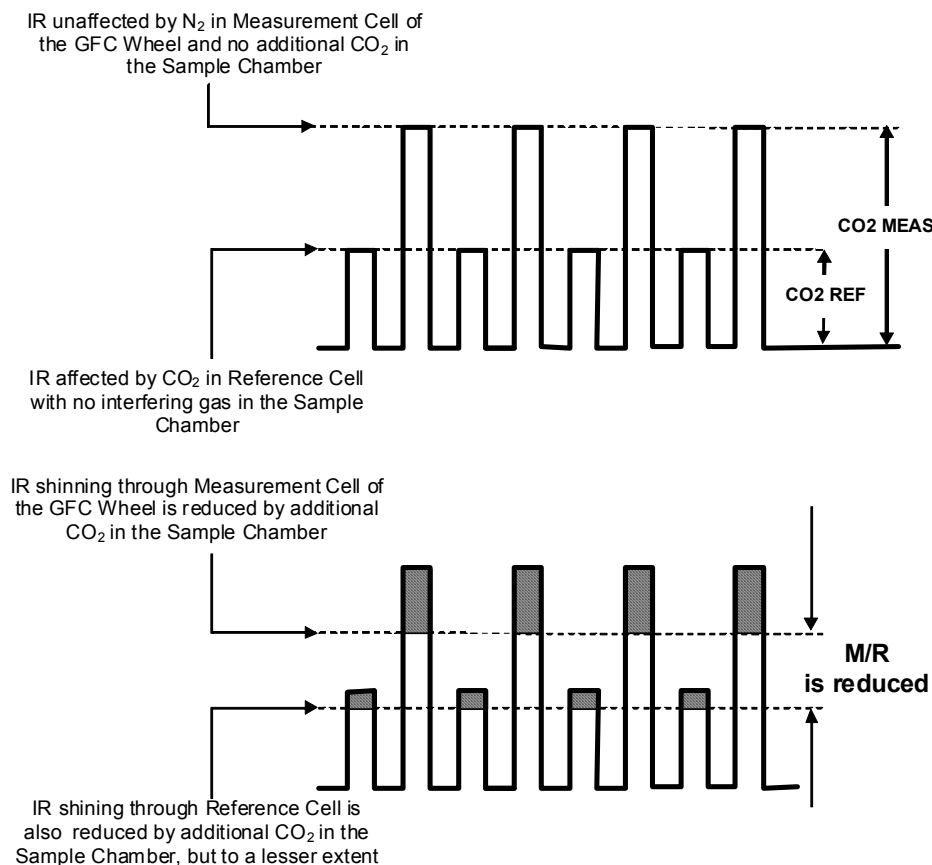

Figure 7-4: Effect of CO₂ in the Sample on CO₂ MEAS and CO₂ REF

Once the Model T360 has computed this ratio, a look-up table is used, with interpolation, to linearize the response of the instrument. This linearized concentration value is combined with calibration **SLOPE** and **OFFSET** values to produce the CO₂ concentration which is then normalized for changes in sample pressure.

7.1.4. Interference and Signal to Noise Rejection

If an interfering gas, such as H₂O vapor is introduced into the sample chamber, the spectrum of the IR beam is changed in a way that is identical for both the reference and the measurement cells, but without changing the ratio between the peak heights of **CO₂ MEAS** and **CO₂ REF**. In effect, the difference between the peak heights remains the same.

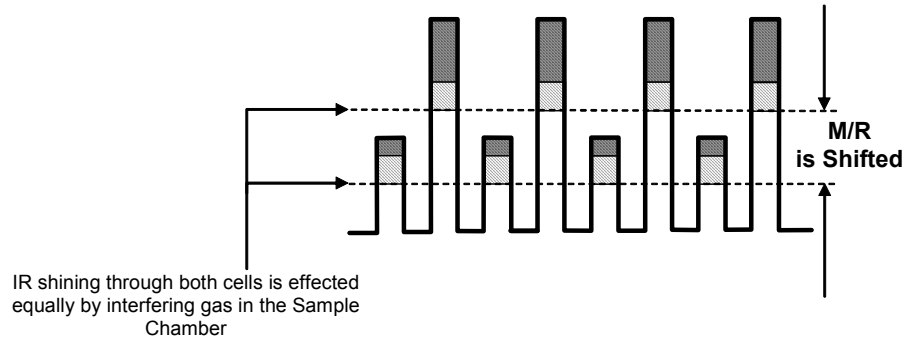

Figure 7-5: Effects of Interfering Gas on CO₂ MEAS & CO₂ REF

Thus, the difference in the peak heights and the resulting M/R ratio is only due to CO₂ and not to interfering gases. In this way, Gas filter correlation rejects the effects of interfering gases and so that the analyzer responds only to the presence of CO₂.

To improve the signal-to-noise performance of the IR photo-detector, the GFC wheel also incorporates an optical mask that chops the IR beam into alternating pulses of light and dark at six times the frequency of the measure/reference signal. This limits the detection bandwidth helping to reject interfering signals from outside this bandwidth improving the signal to noise ratio.

The IR Signal as the Photo-Detector sees it after being chopped by the GFC Wheel Screen

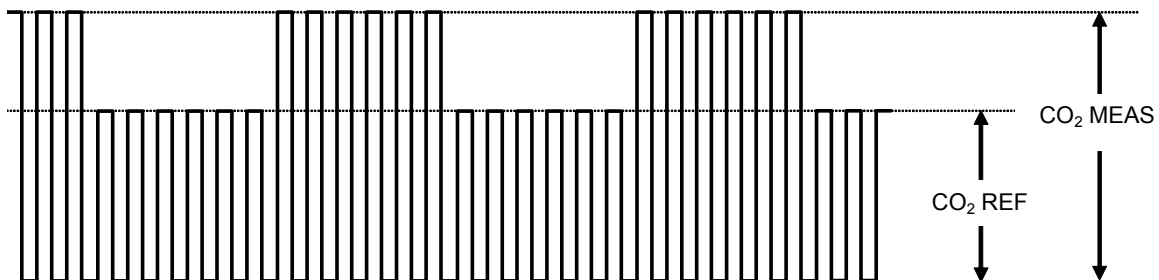

Figure 7-6: Chopped IR Signal

7.1.4.1. AMBIENT CO₂ INTERFERENCE REJECTION

CO₂ absorbs IR light so well that even the narrow volume of ambient air between the IR source and the sample chamber is enough to alter the analyzer's measured concentration of CO₂. Also, ambient air, which averages around 350 ppm to 400 ppm, will vary significantly over the course of the day. The ambient CO₂ concentration can rise as high as 1 000 ppm during the time of the day when people are present. It can fluctuate \pm 300 ppm as the photosynthesis of plant life in the nearby area increases during the day and decreases at night.

The basic design of the T360 rejects most of this interference at a 100:1 ratio; however this still can allow small fluctuations in CO₂ concentration during the course of the day. To completely remove all effects of ambient CO₂ from the analyzer's measurement of CO₂, dried air, scrubbed of all CO₂ is pumped into the GFC wheel housing to purge all ambient CO₂.

7.2. OXYGEN SENSOR (OPT 65)

7.2.1. Paramagnetic Measurement of O₂

The oxygen sensor used in the T360 analyzer utilizes the fact that oxygen is attracted into strong magnetic field; most other gases are not, to obtain fast, accurate oxygen measurements.

The sensor's core is made up of two nitrogen filled glass spheres, which are mounted on a rotating suspension within a magnetic field (Figure 7-7). A mirror is mounted centrally on the suspension and light is shone onto the mirror that reflects the light onto a pair of photocells. The signal generated by the photocells is passed to a feedback loop, which outputs a current to a wire winding (in effect, a small DC electric motor) mounted on the suspended mirror.

Oxygen from the sample stream is attracted into the magnetic field displacing the nitrogen filled spheres and causing the suspended mirror to rotate. This changes the amount of light reflected onto the photocells and therefore the output levels of the photocells. The feedback loop increases the amount of current fed into the winding in order to move the mirror back into its original position. The more O₂ present, the more the mirror moves and the more current is fed into the winding by the feedback control loop.

A sensor measures the amount of current generated by the feedback control loop which is directly proportional to the concentration of oxygen within the sample gas mixture.

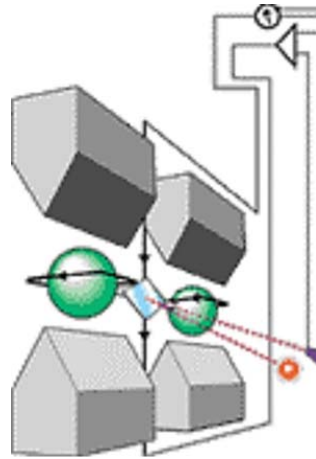

Figure 7-7: Oxygen Sensor - Principle of Operation

7.2.1.1. O₂ SENSOR OPERATION WITHIN THE T360 ANALYZER

The oxygen sensor option is transparently integrated into the core analyzer operation. All functions can be viewed or accessed through the front panel, just like the functions for CO₂.

- The O₂ concentration is displayed in the upper right area of the display with CO₂ concentration.
- Test functions for O₂ slope and offset are viewable from the front panel along with the analyzer's other test functions.
- O₂ sensor calibration is performed via the front panel **CAL** function and is performed in a nearly identical manner as the standard CO₂ calibration. See Section 3.8.1 for more details.
- Stability of the O₂ sensor can be viewed via the front panel display.
- A signal representing the currently measured O₂ concentration is available.

The O₂ concentration range is 0-100% (user selectable) with 0.1% precision and accuracy and is available to be output via the instrument's analog output channel **A3** (see Section 4.13.4).

The temperature of the O₂ sensor is maintained at a constant 50° C by means of a PID loop and can be viewed on the front panel as test function **O2 TEMP**.

The O₂ sensor assembly itself does not have any serviceable parts and is enclosed in an insulated canister.

7.3. PNEUMATIC OPERATION



CAUTION

It is important that the sample airflow system is both leak tight and not pressurized over ambient pressure. Perform regular leak checks (refer to the maintenance schedule, Table 6-1) on the analyzer as described in the procedures for correctly performing leak checks in Section 6.3.3.

An internal pump evacuates the sample chamber creating a small vacuum that draws sample gas into the analyzer. Normally the analyzer is operated with its inlet near ambient pressure either because the sample is directly drawn at the inlet or a small vent is installed at the inlet. There are several advantages to this “pull through” configuration.

- By placing the pump down stream from the sample chamber several problems are avoided.
- First the pumping process heats and compresses the sample air complicating the measurement process.
- Additionally, certain physical parts of the pump itself are made of materials that might chemically react with the sample gas.
- Finally, in certain applications where the concentration of the target gas might be high enough to be hazardous, maintaining a negative gas pressure relative to ambient means that should a minor leak occur, no sample gas will be pumped into the atmosphere surrounding analyzer.

7.3.1. Sample Gas Flow

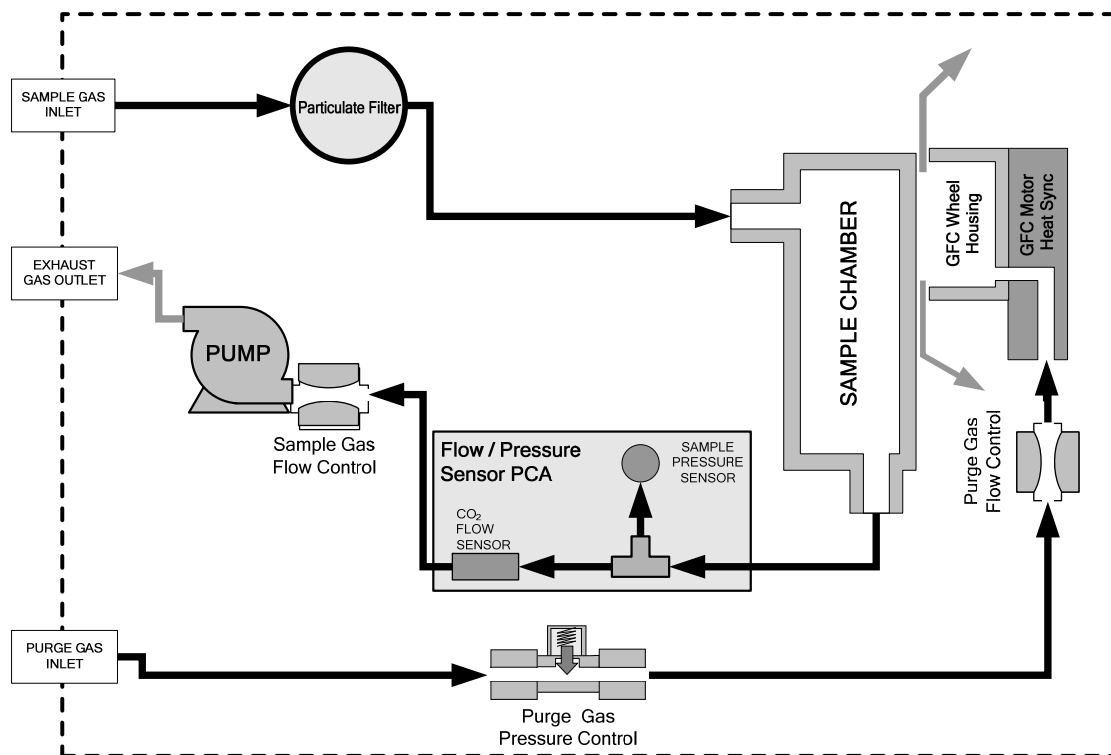

Figure 7-8: Internal Pneumatic Flow – Basic Configuration

7.3.2. Flow Rate Control

To maintain a constant flow rate of the sample gas through the instrument, the Model T360 uses special flow control assemblies located in the purge gas line at the entrance to the GFC wheel housing and in the exhaust gas line just before the pump (Figure 7-8). These assemblies consists of:

- a critical flow orifice.
- two o-rings: Located just before and after the critical flow orifice, the o-rings seal the gap between the walls of assembly housing and the critical flow orifice.
- a spring: Applies mechanical force needed to form the seal between the o-rings, the critical flow orifice and the assembly housing.

7.3.2.1. CRITICAL FLOW ORIFICE

The most important component of this flow control assembly is the critical flow orifice.

Critical flow orifices are a remarkably simple way to regulate stable gas flow rates. They operate without moving parts by taking advantage of the laws of fluid dynamics. By restricting the flow of gas through the orifice, a pressure differential is created. This pressure differential combined with the action of the analyzer's pump draws the gas through the orifice.

As the pressure on the downstream side of the orifice (the pump side) continues to drop, the speed that the gas flows through the orifice continues to rise. Once the ratio of upstream pressure to downstream pressure is greater than 2:1, the velocity of the gas through the orifice reaches the speed of sound. As long as that ratio stays at least 2:1 the gas flow rate is unaffected by any fluctuations, surges, or changes in downstream pressure because such variations only travel at the speed of sound themselves and are therefore cancelled out by the sonic shockwave at the downstream exit of the critical flow orifice.

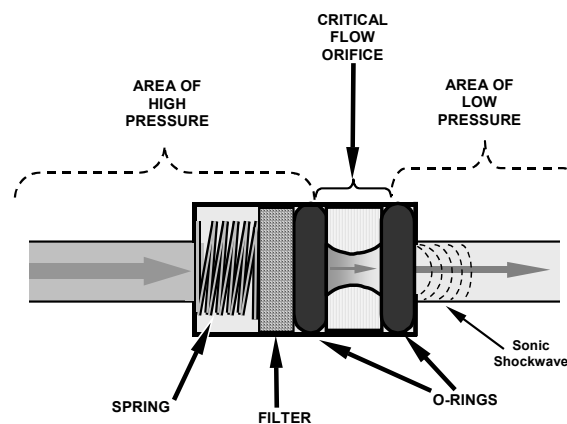

Figure 7-9: Flow Control Assembly & Critical Flow Orifice

The actual flow rate of gas through the orifice (volume of gas per unit of time), depends on the size and shape of the aperture in the orifice. The larger the hole, the more gas molecules, moving at the speed of sound, pass through the orifice. Because the flow rate of gas through the orifice is only related to the minimum 2:1 pressure differential and not absolute pressure the flow rate of the gas is also unaffected by degradations in pump efficiency due to age.

The critical flow orifice used in the Model T360 is designed to provide a flow rate of 800 cm³/min.

7.3.3. Purge Gas Pressure Control

In order to ensure that all of the ambient CO₂ is purged from the GFC Wheel housing an adequate supply of dried air, scrubbed of CO₂ must be supplied to the **PURGE AIR** inlet at the back of the instrument.

- The minimum gas pressure of the source of purge air should be 7.5 psig.
- If the source of the purge air is shared by a Teledyne API's T700 the minimum gas pressure should be 25 psig and should not exceed 35 psig.

In order to maintain the proper pressure differential between the inside of the GFC wheel housing and ambient air, the T360 design includes a manually adjustable pressure regulator (see Figure 3-5 and Figure 3-6 for **Purge Gas Pressure Regulator**) that maintains the pressure of the purge air feed at 7.5 psig.

7.3.4. Particulate Filter

The Model T360 Analyzer comes equipped with a 47 mm diameter, Teflon, particulate filter with a 5 micron pore size. The filter is accessible through the front panel, which folds down to allow access, and should be changed according to the suggested maintenance schedule described in Table 6-1.

7.3.5. Pneumatic Sensors

7.3.5.1. SAMPLE PRESSURE SENSOR

An absolute value pressure transducer plumbed to the outlet of the sample chamber is used to measure sample pressure. The output of the sensor is used to compensate the concentration measurement for changes in air pressure. This sensor is mounted to a printed circuit board with the sample flow sensor on the sample chamber; see the following section and Figure 3-5.

7.3.5.2. SAMPLE FLOW SENSOR

A thermal-mass flow sensor is used to measure the sample flow through the analyzer. The sensor is calibrated at the factory with ambient air or N₂, but can be calibrated to operate with samples consisting of other gases such as CO₂. This sensor is mounted to a printed circuit board with the Sample Pressure sensor on the sample chamber; see the previous section and Figure 3-5.

7.3.6. Pneumatic Operation of the O₂ Sensor

Pneumatically, the O₂ sensor is connected to the bypass manifold and draws a flow of about 120 cm³/min in addition to the normal sample flow rate and is separately controlled with its own critical flow orifice. Figure 7-10 shows the internal pneumatics of the analyzer with the O₂ sensor installed.

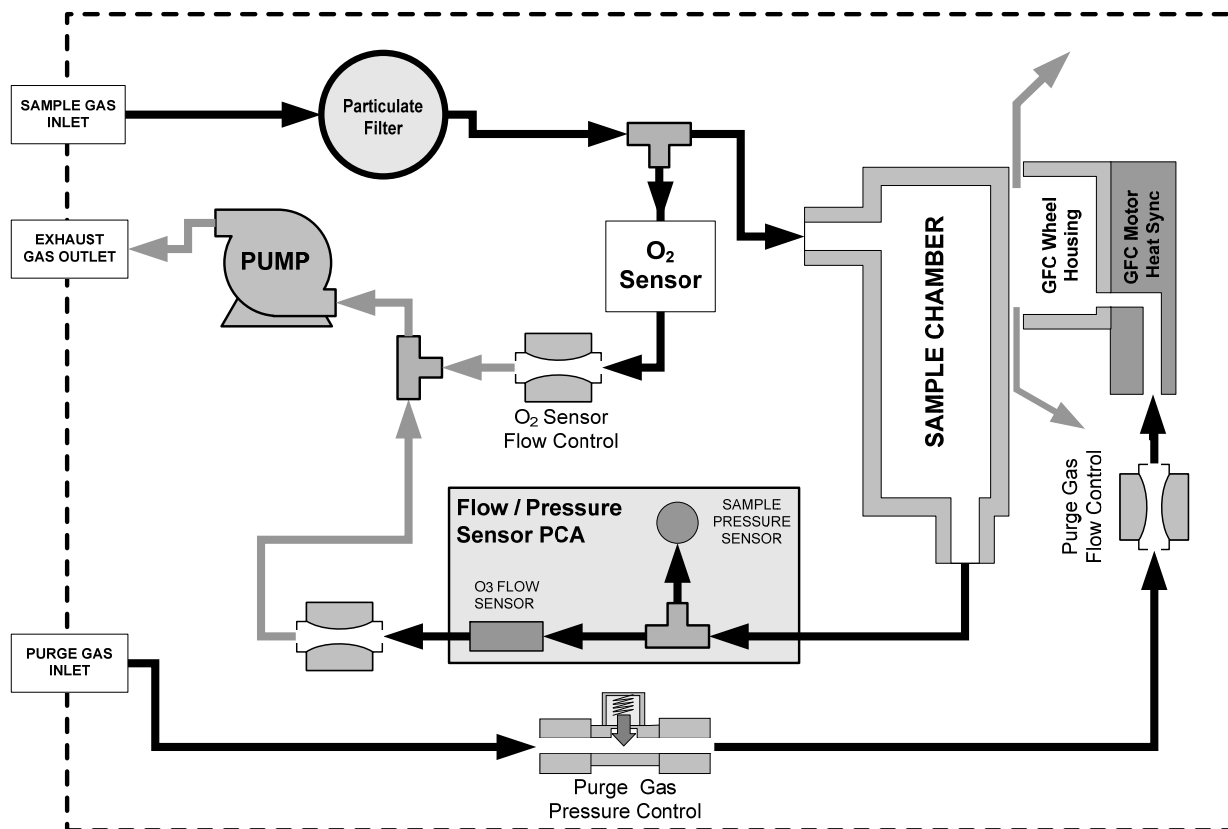

Figure 7-10: Gas Flow with O₂ Sensor Option

7.4. ELECTRONIC OPERATION

7.4.1. Overview

Figure 7-11 shows a block diagram of the major electronic components of the Model T360.

The core of the analyzer is a microcomputer/central processing unit (CPU) that controls various internal processes, interprets data, makes calculations, and reports results using specialized firmware developed by Teledyne API. It communicates with the user as well as receives data from and issues commands to a variety of peripheral devices via a separate printed circuit assembly called the Motherboard.

The motherboard, directly mounted to the analyzer's inside rear panel, collects data, performs signal conditioning duties and routs incoming and outgoing signals between the CPU and the analyzer's other major components.

Data is generated by a gas-filter-correlation optical bench which outputs an analog signal corresponding to the concentration of CO₂ in the sample gas. This analog signal is transformed into two, pre-amplified, DC voltages (**CO2 MEAS** and **CO2 REF**) by a synchronous demodulator printed circuit assembly. **CO2 MEAS** and **CO2 REF** are converted into digital data by a unipolar, analog-to-digital converter, located on the mother board.

A variety of sensors report the physical and operational status of the analyzer's major components, again through the signal processing capabilities of the mother board. These status reports are used as data for the CO₂ concentration calculation and as trigger events for certain control commands issued by the CPU. They are stored in memory by the CPU and in most cases can be viewed but the user via the front panel display.

The CPU communicates with the user and the outside world in a variety of manners:

- Through the analyzer's touchscreen and LCD display over a clocked, digital, serial I/O bus (using a protocol called I²C)
- RS 232 & RS485 Serial I/O channels via Ethernet, Modbus[®], Apicom or a terminal emulation program
- Various DCV and DCA analog outputs, and
- Several sets of Digital I/O channels.

Finally, the CPU issues commands via a series of relays and switches (also over the I²C bus) located on a separate printed circuit assembly to control the function of key electromechanical devices such as heaters, motors and valves.

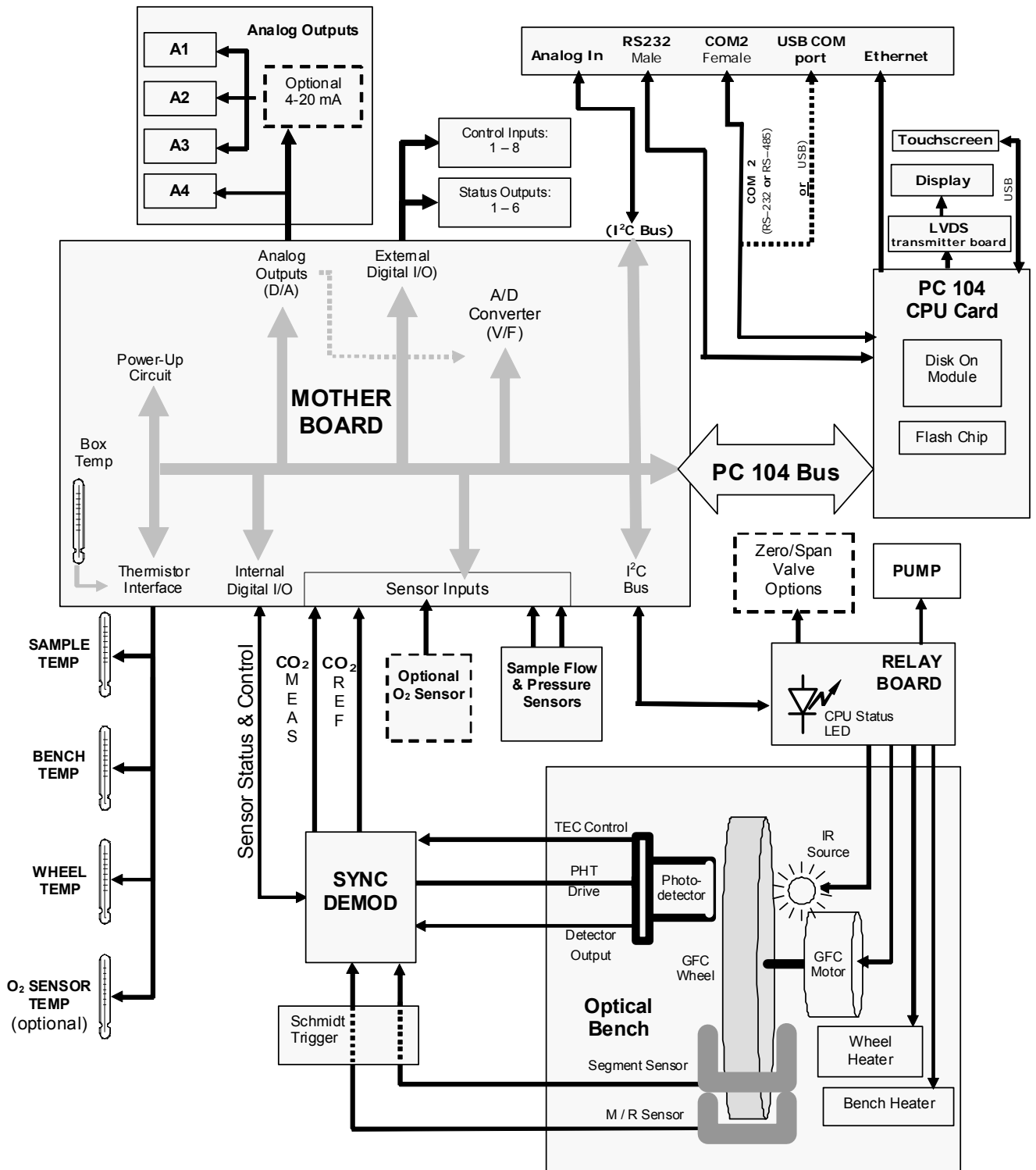

Figure 7-11: T360 Electronic Block Diagram

7.4.2. CPU

The unit's CPU card, installed on the motherboard inside the rear panel, is a low power (5 VDC, 720mA max), high performance, Vortex 86SX-based microcomputer running Windows CE. Its operation and assembly conform to the PC/104 specification.

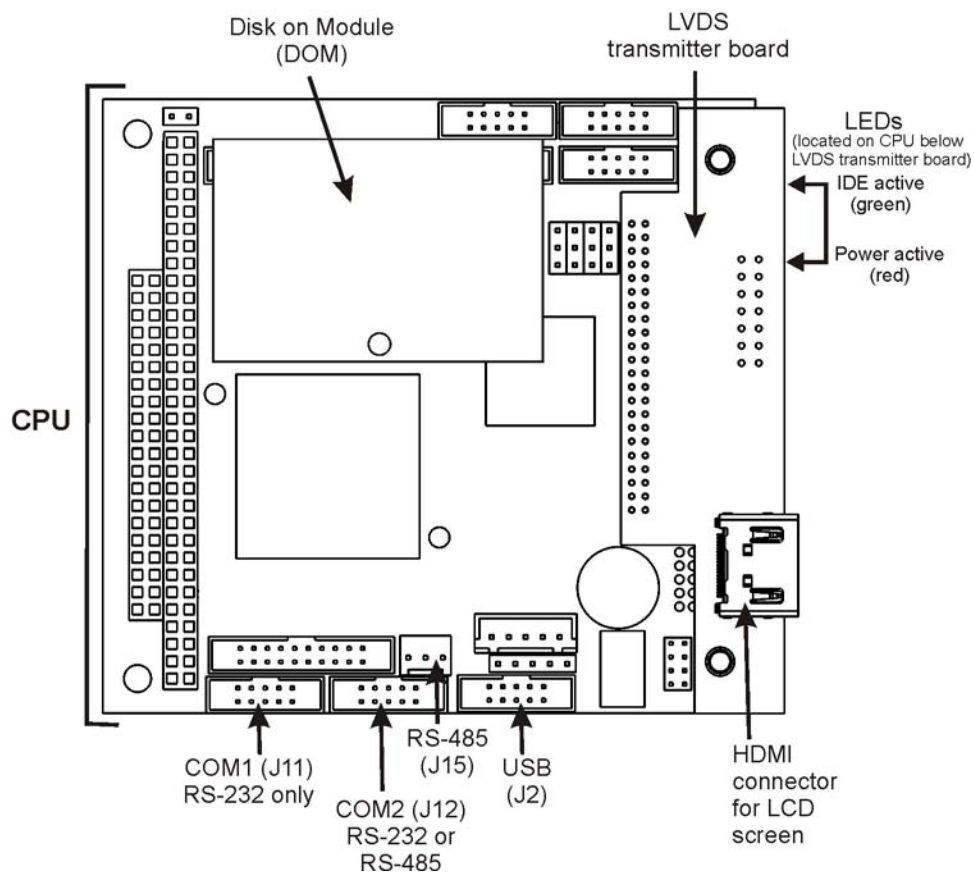

Figure 7-12: CPU Board

The CPU includes non-volatile data storage: a Disk on Module (DOM) with an embedded flash chip.

7.4.2.1. DISK-ON-MODULE (DOM)

The DOM is a 44-pin IDE flash chip with storage capacity to 129 MB. It is used to store the operating system, the Teledyne API firmware, and most of the operational data generated by the analyzer's internal data acquisition system (DAS - see Section 4.7).

7.4.2.2. FLASH CHIP

This non-volatile, embedded flash chip includes 2MB of storage for calibration data as well as a backup of the analyzer configuration. Storing these key data on a separate, less heavily accessed chip significantly decreases the chance of data

corruption. In the unlikely event that the flash chip should fail, the analyzer will continue to operate with just the DOM. However, all configuration information will be lost, requiring that the unit be recalibrated.

7.4.3. Optical Bench & GFC Wheel

Electronically, the Model T360's optical bench, GFC wheel and associated components do more than simply measure the amount of CO₂ present in the sample chamber. A variety of other critical functions are performed here as well.

7.4.3.1. TEMPERATURE CONTROL

Because the temperature of a gas affects its density and therefore the amount of light absorbed by that gas it is important to reduce the effect of fluctuations in ambient temperature on the Model T360's measurement of CO₂. To accomplish this the temperature of both the sample chamber and the GFC Wheel are maintained at constant temperatures above their normal operating ranges.

Bench Temperature: To minimize the effects of ambient temperature variations on the sample measurement, the sample chamber is heated to 48°C (8 degrees above the maximum suggested ambient operating temperature for the analyzer). The heat source is a strip heater attached to the underside of the chamber housing. The temperature of the sample chamber is sensed by a thermistor attached to the sample chamber housing.

Wheel Temperature: To minimize the effects of temperature variations caused by the near proximity of the IR Source to the GFC wheel on the gases contained in the wheel, it is also raised to a high temperature level. Because the IR Source itself is very hot, the set point for this heat circuit is 68°C. The heat source is a cartridge heater implanted into the heat sync on the motor. The temperature of the wheel/motor assembly is sensed by a thermistor inserted into the heat sync.

Both heaters operate off of the AC line voltage supplied to the instrument.

7.4.3.2. IR SOURCE

The light used to detect CO₂ in the sample chamber is generated by an element heated to approximately 1100°C producing infrared radiation across a broad band. This radiation is optically filtered after it has passed through the GFC Wheel and the sample chamber and just before it reaches the photo-detector to eliminate all black body radiation and other extraneous IR emitted by the various components of those components.

7.4.3.3. GFC WHEEL

A synchronous AC motor turns the GFC wheel motor. For analyzers operating on 60Hz line power this motor turns at 1800 rpm. For those operating on 50Hz line power the spin rate is 1500 rpm. The actual spin rate is unimportant within a large rate since a phase lock loop circuit is used to generate timing pulses for signal processing.

In order to accurately interpret the fluctuations of the IR beam after it has passed through the sample gas, the GFC wheel several other timing signals are produced by other photo emitters/detectors. These devices consist of a combination LED and detector mounted so that the light emitted by the LED shines through the same mask on the GFC wheel that chops the IR beam.

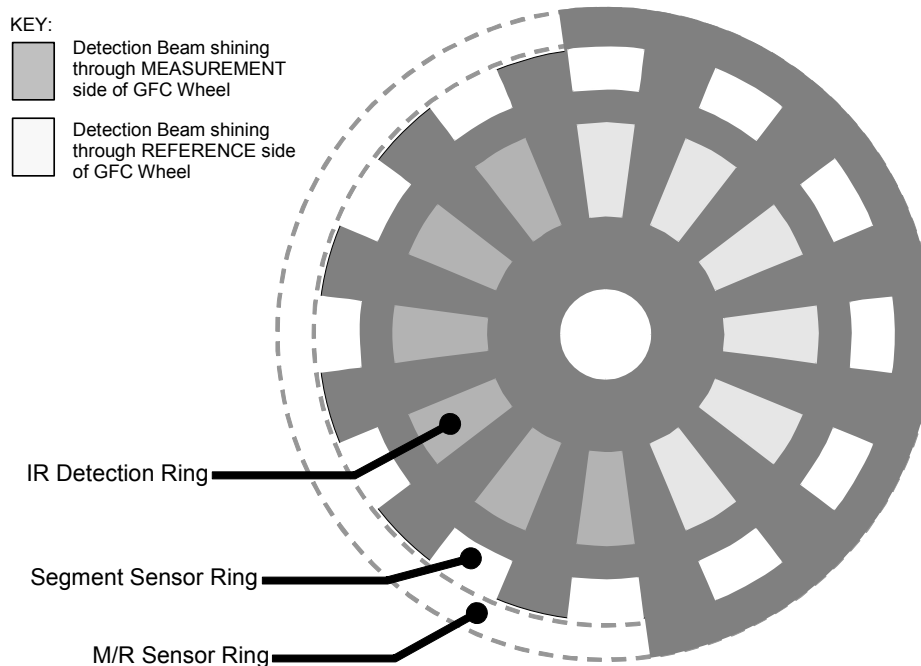

Figure 7-13: GFC Light Mask

M/R Sensor

This emitter/detector assembly produces a signal that shines through a portion of the mask that allows light to pass for half of a full revolution of the wheel. The resulting light signal tells the analyzer whether the IR beam is shining through the measurement or the reference side of the GFC wheel.

Segment Sensor

Light from this emitter/detector pair shines through a portion of the mask that is divided into the same number of segments as the IR detector ring. It is used by the synchronous / demodulation circuitry of the analyzer to latch onto the most stable part of each measurement and reference IR pulse.

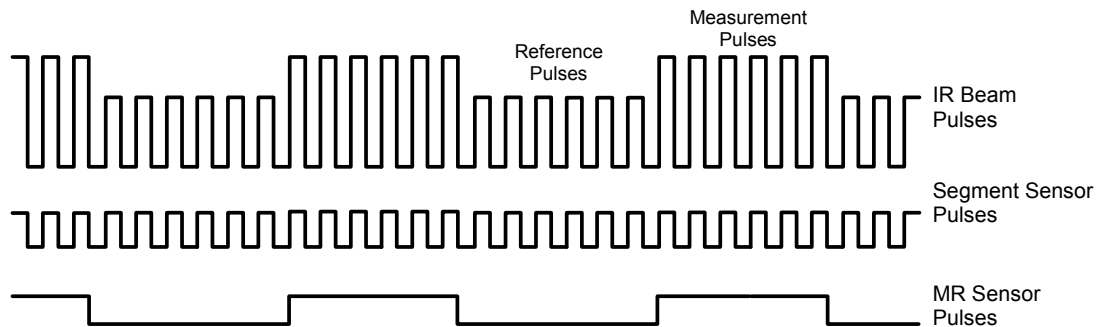

Figure 7-14: Segment Sensor and M/R Sensor Output

Schmidt Triggers

To ensure that the waveforms produced by the Segment Sensor and the M/R Sensor are properly shaped and clean, these signals are passed through a set of Schmidt Triggers circuits.

7.4.3.4. IR PHOTO-DETECTOR

The IR beam is converted into an electrical signal by a cooled solid-state photo-conductive detector. The detector is composed of a narrow-band optical filter, a piece of lead-salt crystal whose electrical resistance changes with temperature, and a two-stage thermo-electric cooler.

When the analyzer is on, a constant electrical current is directed through the detector. The IR beam is focused onto the detector surface, raising its temperature and lowering its electrical resistance that results in a change in the voltage drop across the detector.

During those times that the IR beam is bright, the temperature of the detector is high; the resistance of the detector is correspondingly low and the its output voltage output is low. During those times when the IR beam intensity is low or completely blocked by the GFC Wheel mask, the temperature of the detector is lowered by the two-stage thermo-electric cooler, increasing the detectors resistance and raising the output voltage.

7.4.4. Synchronous Demodulator (Sync/Demod) Assembly

7.4.4.1. OVERVIEW

While the photo-detector converts fluctuations of the IR beam into electronic signals, the Sync / Demod Board amplifies these signals and converts them into usable information. Initially the output by the photo-detector is a complex and continuously changing waveform made up of Measure and Reference pulses. The sync/demod board demodulates this waveform and outputs two analog DC voltage signals, corresponding to the peak values of these pulses. **CO₂ MEAS** and **CO₂ REF** are converted into digital signals by circuitry on the motherboard then used by the CPU to calculate the CO₂ concentration of the sample gas.

Additionally the synch/demod board contains circuitry that controls the photo-detector's thermoelectric cooler as well as circuitry for performing certain diagnostic tests on the analyzer.

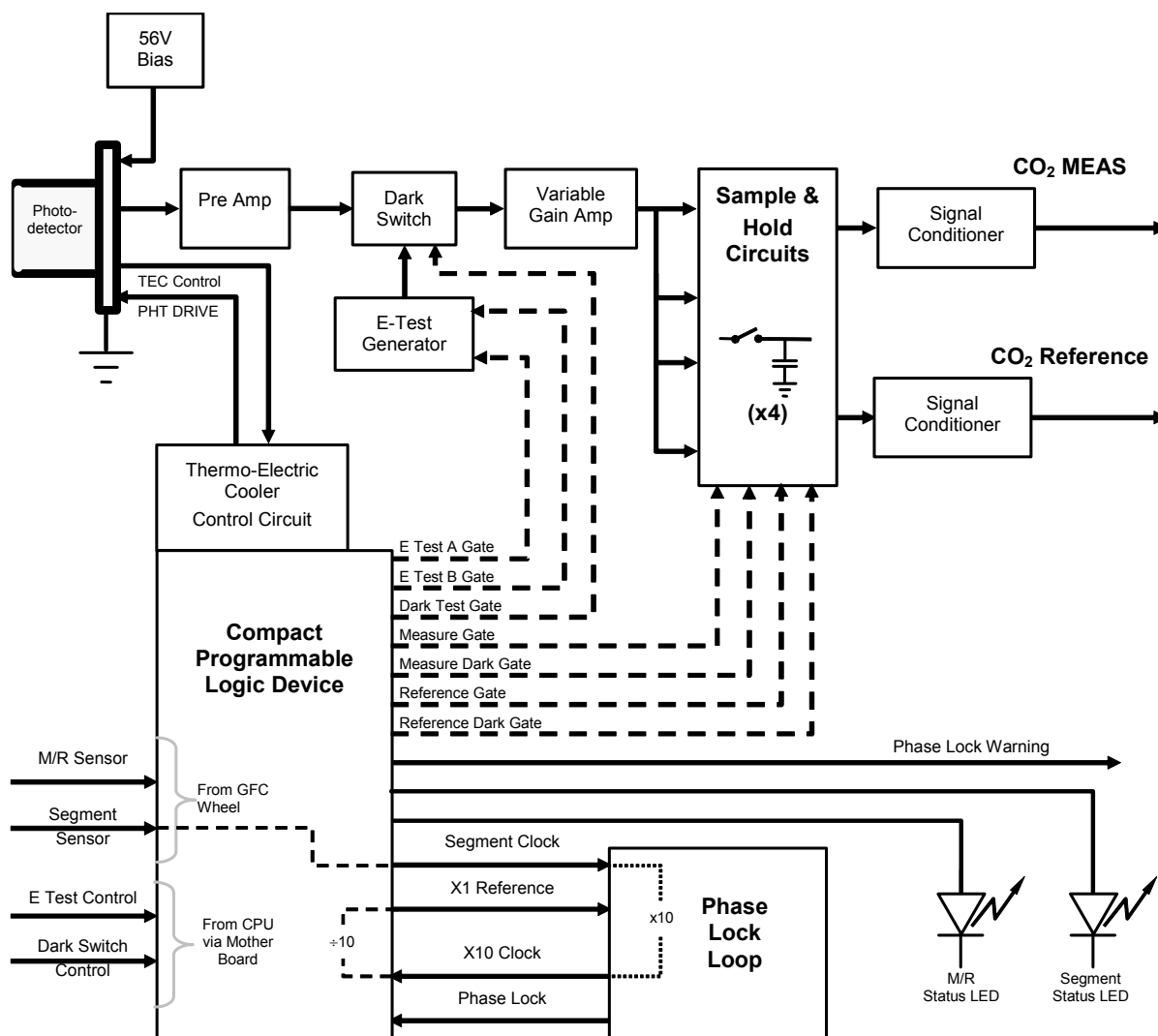

Figure 7-15: T360 Sync / Demod Block Diagram

7.4.4.2. SIGNAL SYNCHRONIZATION AND DEMODULATION

The signal emitted by the IR photo-detector goes through several stages of amplification before it can be accurately demodulated. The first is a pre-amplification stage that raises the signal to levels readable by the rest of the synch/demod board circuitry. The second is a variable amplification stage that is adjusted at the factory to compensate for performance variations of mirrors, detectors, and other components of the optical bench from instrument to instrument.

The workhorses of the synch/demod board are the four sample-and-hold circuits that capture various voltage levels found in the amplified detector signal needed to determine the value of **CO2 MEAS** and **CO2 REF**. They are activated by logic signals under the control of a compact programmable logic device (PLD), which in turn responds to the output of the Segment Sensor and M/R Sensor depicted in Figure 7-14.

The four sample and hold circuits are:

DESIGNATION	ACTIVE WHEN:	
	IR BEAM PASSING THROUGH	SEGMENT SENSOR PULSE IS:
Measure Gate	MEASUREMENT cell of GFC Wheel	HIGH
Measure Dark Gate	MEASUREMENT cell of GFC Wheel	LOW
Reference Gate	REFERENCE cell of GFC Wheel	HIGH
Reference Dark Gate	REFERENCE cell of GFC Wheel	LOW

Timing for activating the Sample and Hold circuits is provided by a phase lock loop circuit (PLL). Using the segment sensor output as a reference signal the PLL generates clock signal at ten times that frequency. This faster clock signal is used by the PLD to make the sample and hold circuits capture the signal during the center portions of the detected waveform, ignore the rising and falling edges of the detector signal.

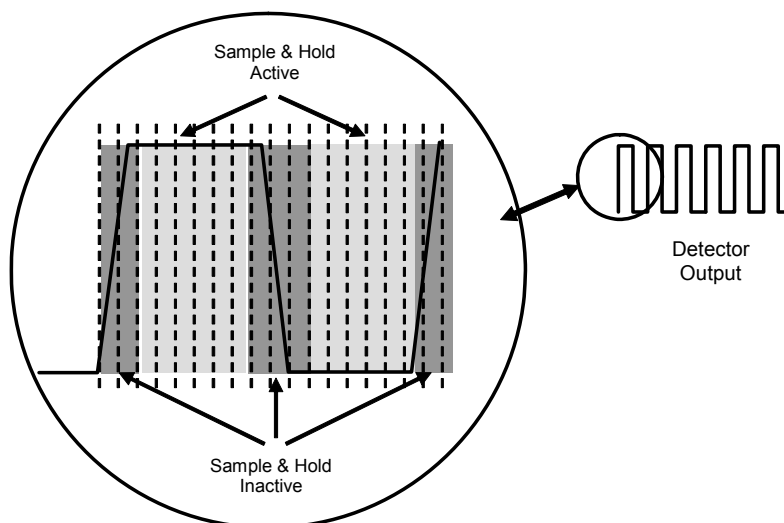

Figure 7-16: Sample & Hold Timing

7.4.4.3. SYNC/DEMODO STATUS LED'S

The following two status LED's located on the synch/demod board provide additional diagnostic tools for checking the GFC wheel rotation.

Table 7-1: Sync/Demod Status LED Activity

LED	FUNCTION	STATUS OK	FAULT STATUS
D1	M/R Sensor Status	LED flashes approximately 2/second	LED is stuck ON or OFF
D2	Segment Sensor Status	LED flashes approximately 6/second	LED is stuck ON or OFF

See Section 8.1.4 for more information.

7.4.4.4. PHOTO-DETECTOR TEMPERATURE CONTROL

The synch/demod board also contains circuitry that controls the IR photo-detector's thermoelectric coolers. A drive voltage, **PHT DRIVE**, is supplied to the coolers by the synch/demod board which is adjusted by the synch/demod board based on a return signal called TEC control which alerts informs the synch/demod board of the detector's temperature. The warmer the detector, the harder the coolers are driven.

PHT DRIVE is one of the Test Functions viewable by the user via the front panel. Press <TST or TST> until it appears on the display.

7.4.4.5. DARK CALIBRATION SWITCH

This switch initiates the Dark Calibration procedure. When initiated by the user (see Section 4.13.6 for more details), the dark calibration process opens this switch, interrupting the signal from the IR photo-detector. This allows the analyzer to measure any offset caused by the synch/demod board circuitry.

7.4.4.6. ELECTRIC TEST SWITCH

When active this circuit generates a specific waveform intended to simulate the function of the IR photo-detector but with a known set of value which is substituted for the detector's actual signal via the dark switch. It may also be initiated by the user (see Section 4.13.5 for more details).

7.4.5. Relay Board

By actuating various switches and relays located on this board, the CPU controls the status of other key components. The relay board receives instructions in the form of digital signals over the I²C bus, interprets these digital instructions and activates its various switches and relays appropriately.

7.4.5.1. HEATER CONTROL

The two heaters attached to the sample chamber housing and the GFC wheel motor are controlled by solid state relays located on the relay board.

The GFC wheel heater is simply turned on or off, however control of the bench heater also includes circuitry that selects which one of its two separate heating elements is activated depending on whether the instrument is running on 100 VAC, 115 VAC or 230 VAC line power.

7.4.5.2. GFC WHEEL MOTOR CONTROL

The GFC wheel operates from an AC voltage supplied by a multi-input transformer located on the relay board. The step-down ratio of this transformer is controlled by factory-installed jumpers to adjust for 100 VAC, 115 VAC or 230 VAC line power. Other circuitry slightly alters the phase of the AC power supplied to the motor during start up based on whether line power is 50Hz or 60 Hz.

Normally, the GFC Wheel Motor is always turning while the analyzer is on. A physical switch located on the relay board can be used to turn the motor off for certain diagnostic procedures.

7.4.5.3. ZERO/SPAN VALVE OPTIONS

Any zero/span valve options installed in the analyzer are controlled by a set of electronic switches located on the relay board. These switches, under CPU control, supply the +12VDC needed to activate each valve's solenoid.

7.4.5.4. IR SOURCE

The Relay board supplies a constant 11.5VDC to the IR Source. Under normal operation the IR source is always on.

7.4.5.5. STATUS LEDES

Eight LEDs are located on the analyzer's relay board to show the current status on the various control functions performed by the relay board (see Figure 7-17). They are:

Table 7-2: Relay Board Status LED's

LED	COLOR	FUNCTION	STATUS WHEN LIT	STATUS WHEN UNLIT
D1	RED	Watchdog Circuit	Cycles On/Off Every 3 Seconds under direct control of the analyzer's CPU.	
D2	YELLOW	Wheel Heater	HEATING	NOT HEATING
D3	YELLOW	Bench Heater	HEATING	NOT HEATING
D4	YELLOW	Spare	N/A	N/A
D5	GREEN	Sample/Cal Gas Valve Option	Valve Open to CAL GAS FLOW	Valve Open to SAMPLE GAS FLOW
D6	GREEN	Zero/Span Gas Valve Option	Valve Open to SPAN GAS FLOW	Valve Open to ZERO GAS FLOW
D7	GREEN	Shutoff Valve Option	Valve Open to CAL GAS FLOW	Valve CLOSED to CAL GAS FLOW
D8	GREEN	IR SOURCE	Source ON	Source OFF

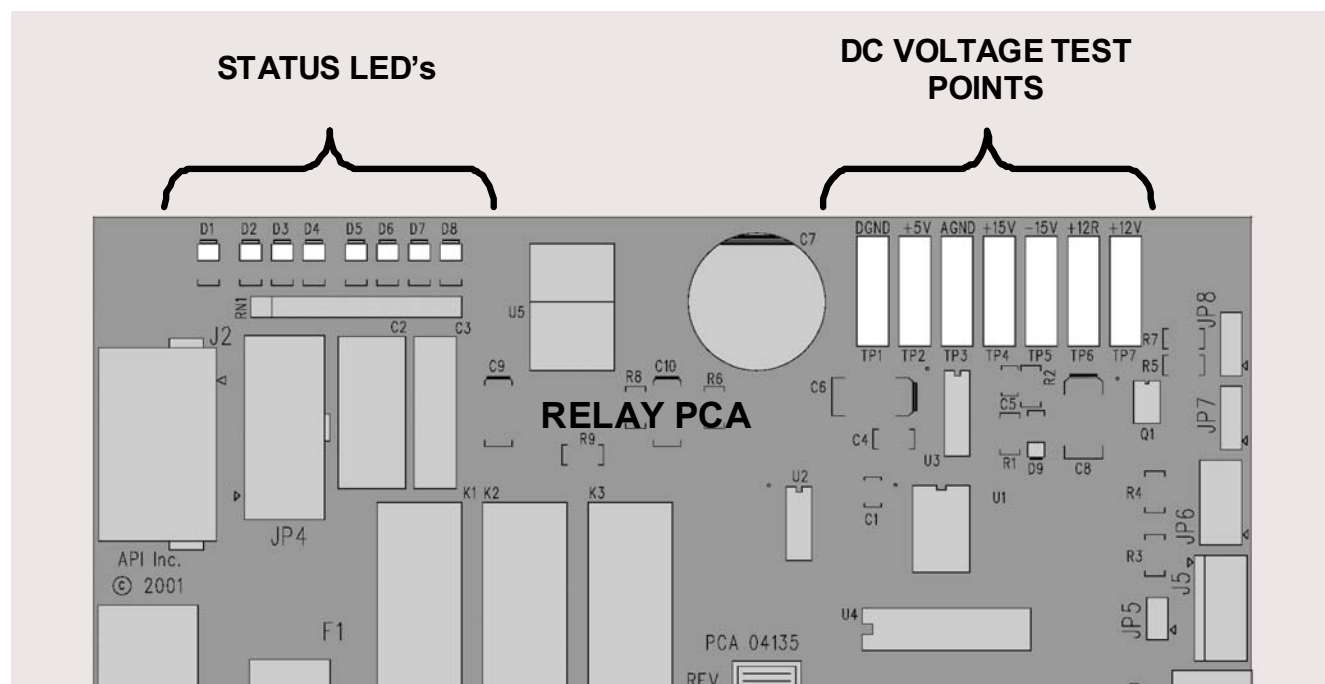

Figure 7-17: Location of relay board Status LED's

7.4.5.6. I²C WATCH DOG CIRCUITRY

Special circuitry on the relay board monitors the activity on the I²C bus and drives LED D1. Should this LED ever stay **ON** or **OFF** for 30 seconds, the watchdog circuit will automatically shut of all valves as well as turn off the IR Source and all heaters. The GFC wheel motor will still be running as will the Sample Pump, which is not controlled by the relay board.

7.4.6. Motherboard

This printed circuit assembly provides a multitude of functions including, A/D conversion, digital input/output, PC-104 to I2C translation, temperature sensor signal processing and is a pass through for the RS-232 and RS-485 signals.

7.4.6.1. A TO D CONVERSION

Analog signals, such as the voltages received from the analyzer's various sensors, are converted into digital signals that the CPU can understand and manipulate by the analog to digital converter (A/D). Under the control of the CPU, this functional block selects a particular signal input (e.g. **BOX TEMP**, **CO2 MEAS**, **CO2 REF**, etc.) and then converts the selected voltage into a digital word.

The A/D consists of a voltage-to-frequency (V-F) converter, a programmable logic device (PLD), three multiplexers, several amplifiers and some other associated devices. The V-F converter produces a frequency proportional to its input voltage. The PLD counts the output of the V-F during a specified time period, and sends the result of that count, in the form of a binary number, to the CPU.

The A/D can be configured for several different input modes and ranges but in the T360 is used in uni-polar mode with a +5 V full scale. The converter includes a 1% over and under-range. This allows signals from -0.05 V to +5.05 V to be fully converted.

For calibration purposes, two reference voltages are supplied to the A/D converter: Reference Ground and +4.096 VDC. During calibration, the device measures these two voltages, outputs their digital equivalent to the CPU. The CPU uses these values to compute the converter's offset and slope and uses these factors for subsequent conversions.

See Section 4.13.4 for instructions on performing this calibration.

7.4.6.2. SENSOR INPUTS

The key analog sensor signals are coupled to the A/D through the master multiplexer from two connectors on the motherboard. 100K terminating resistors on each of the inputs prevent cross talk from appearing on the sensor signals.

CO₂ Measure and Reference

These are the primary signals that are used in the computation of the CO₂ concentration. They are the demodulated IR-sensor signals from the sync demodulator board.

Sample Pressure and Flow

These are analog signals from two sensors that measure the pressure and flow rate of the gas stream at the outlet of the sample chamber. This information is used in two ways. First, the sample pressure is used by the CPU to calculate CO₂ Concentration. Second, the pressure and flow rate are monitored as a test function to assist the user in predicting and troubleshooting failures.

7.4.6.3. THERMISTOR INTERFACE

This circuit provides excitation, termination and signal selection for several negative-coefficient, thermistor temperature sensors located inside the analyzer. They are:

Sample Temperature Sensor

The source of this signal is a thermistor located inside the sample chamber of the Optical Bench. It measures the temperature of the sample gas in the chamber. This data is used during the calculation of the CO₂ concentration value.

Bench Temperature Sensor

This thermistor, attached to the sample chamber housing, reports the current temperature of the chamber housing to the CPU as part of the bench heater control loop.

Wheel Temperature Sensor

This thermistor (attached to the heat-sync on the GFC wheel motor assembly) reports the current temperature of the wheel/motor assembly to the CPU as part of the Wheel Heater control loop.

Box Temperature Sensor

A thermistor is attached to the motherboard. It measures the analyzer's inside temperature. This information is stored by the CPU and can be viewed by the user for troubleshooting purposes via the front panel display (see Section 8.1.2).

7.4.6.4. ANALOG OUTPUTS

The analyzer comes equipped with four analog outputs: A1, A2, A3 and A4. . In its standard configuration, the analyzer comes with all four of these channels set up to output a DC voltage. However, 4-20mA current loop drivers can be purchased for the first three of these outputs: A1, A2 & A3.

A2 and A1 Output

The first two, A2 and A1 are normally set up to operate in parallel so that the same data can be sent to two different recording devices. While the names imply that one should be used for sending data to a chart recorder and the other for interfacing with a data logger, either can be used for both applications.

Both of these channels output a signal that is proportional to the CO₂ concentration of the sample gas. The A1 and A2 outputs can be slaved together or set up to operate independently. A variety of scaling factors are available; see Section 4.13.4 for information on setting the range type and scaling factors for these output channels.

A3 Output

Analog output channel **A3** is only active when the O₂ sensor option is installed in the T360. In this case, the currently measured O₂ concentration is output.

Test Function Output

The fourth analog output, labeled **A4** is special. It can be set by the user (see Section 4.8) to carry the current signal level of any one of the parameters

accessible through the **SETUP → MORE → DIAG → TEST CHAN OUTPUT** submenu (see Section 4.13.9) of the unit's software.

Output Loop-back

All four analog outputs are connected back to the A/D converter through a Loop-back circuit. This permits the voltage outputs to be calibrated by the CPU without need for any additional tools or fixtures.

7.4.6.5. INTERNAL DIGITAL I/O

This channel is used to communicate digital status and control signals about the operation of key components of the Optical Bench. The CPU sends signals to the synch/demod board that initiate the **ELECTRICAL TEST** and **DARK CALIBRATION** procedures. Likewise, the synch/demod board uses this interface to send the **SYNC** warning signal to the CPU (see Sections 4.13.5, 4.13.6, and 8.1.1).

7.4.6.6. EXTERNAL DIGITAL I/O

This External Digital I/O performs two functions: status outputs and control inputs.

Status Outputs

Logic-Level voltages are output through an optically isolated 8-pin connector located on the rear panel of the analyzer. These outputs convey good/bad and on/off information about certain analyzer conditions. They can be used to interface with certain types of programmable devices (Section 4.15.1.1).

Control Inputs

By applying +5VDC power supplied from an external source such as a PLC or Data logger (Section 4.15.1.2), Zero and Span calibrations can be initiated by contact closures on the rear panel.

7.4.7. I²C Data Bus

An I²C data bus is used to communicate data and commands between the CPU and the touchscreen/display interface and the relay board. I²C is a two-wire, clocked, digital serial I/O bus that is used widely in commercial and consumer electronic systems. A transceiver on the motherboard converts data and control signals from the PC-104 bus to I²C. The data is then fed to the touchscreen/display interface and finally onto the relay board.

Interface circuits on the touchscreen/display interface and relay boards convert the I²C data to parallel inputs and outputs. An additional, interrupt line from the touchscreen to the motherboard allows the CPU to recognize and service button presses on the touchscreen.

Power up Circuit

This circuit monitors the +5V power supply during start-up and sets the Analog outputs, external digital I/O ports, and I²C circuitry to specific values until the CPU boots and the instrument software can establish control.

7.4.8. Power Supply/Circuit Breaker

The analyzer operates on 100 VAC, 115 VAC or 230 VAC power at either 50Hz or 60Hz. Individual units are set up at the factory to accept any combination of these five attributes. As illustrated in Figure 7-18, power enters the analyzer through a standard IEC 320 power receptacle located on the rear panel of the instrument. From there it is routed through the On/Off switch located in the lower right corner of the Front Panel. A 6.75 Amp circuit breaker is built into the ON/OFF Switch.

AC power is distributed directly to the sample gas pump. The bench and GFC wheel heaters as well as the GFC wheel receive AC power via the relay board.

AC Line power is converted stepped down and converted to DC power by two DC power supplies. One supplies +12 VDC, for valves and the IR source, while a second supply provides +5 VDC and ± 15 VDC for logic and analog circuitry. All DC voltages are distributed via the relay board.

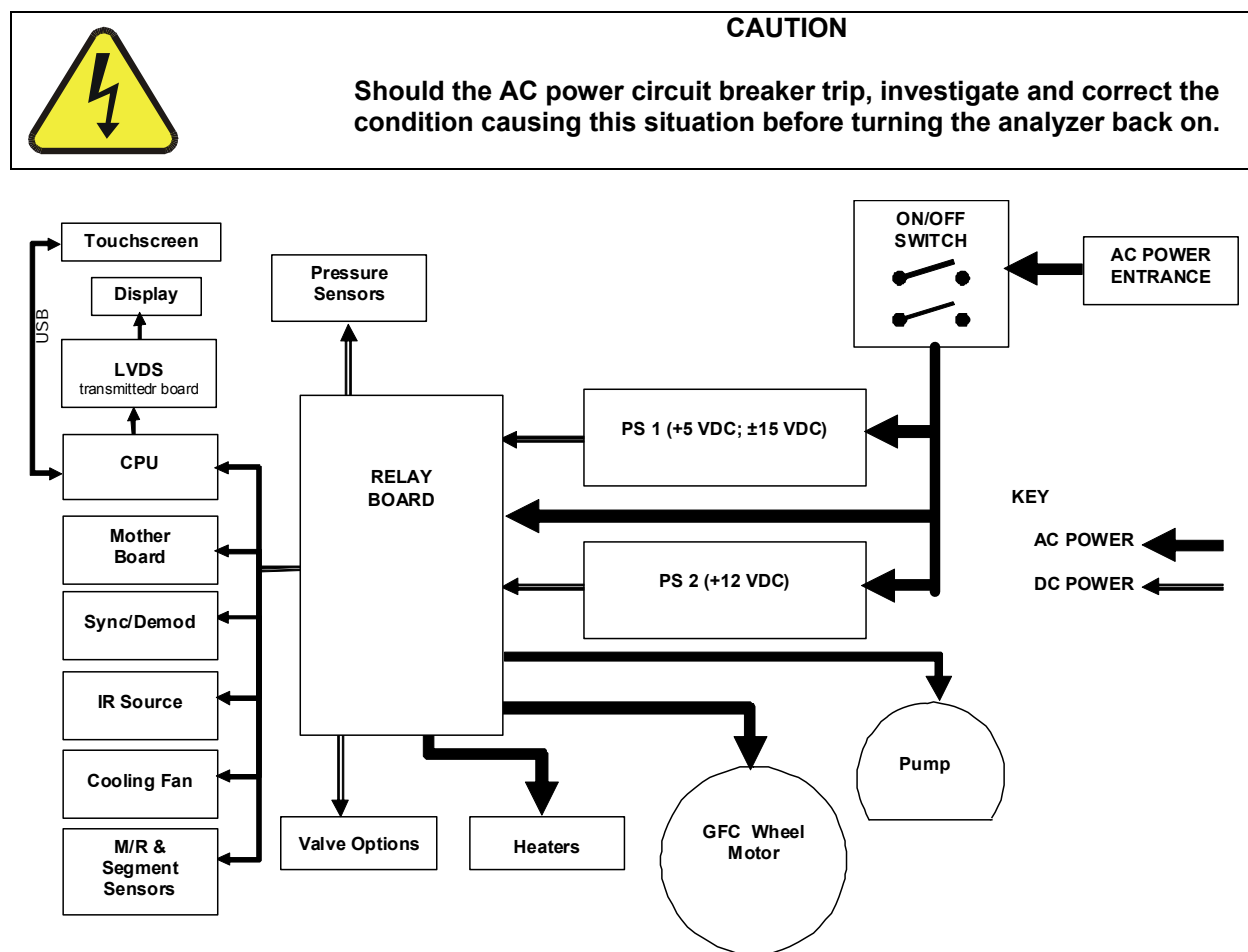

Figure 7-18: Power Distribution Block Diagram

7.5. FRONT PANEL TOUCHSCREEN/DISPLAY INTERFACE

Users can input data and receive information directly through the front panel touchscreen display. The LCD display is controlled directly by the CPU board. The touchscreen is interfaced to the CPU by means of a touchscreen controller that connects to the CPU via the internal USB bus and emulates a computer mouse.

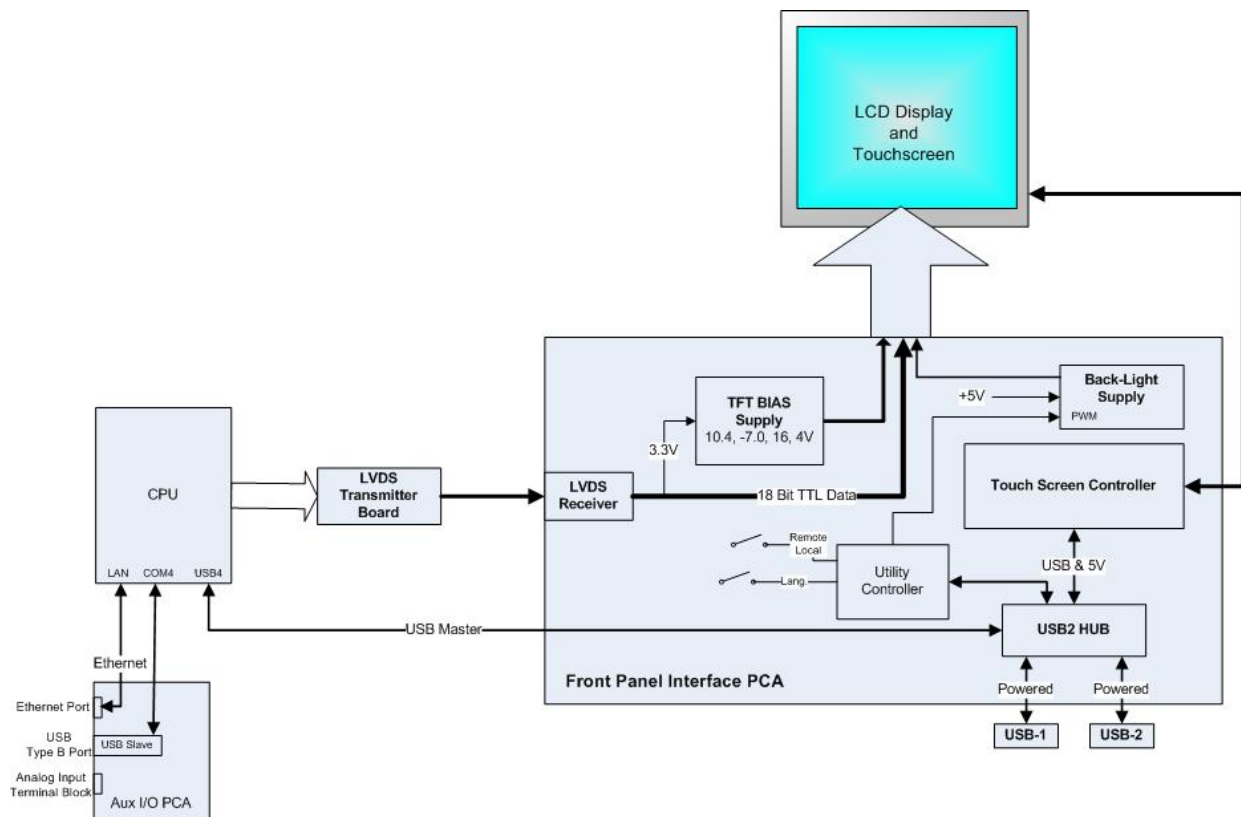

Figure 7-19: Front Panel and Display Interface Block Diagram

7.5.1. LVDS Transmitter Board

The LVDS (low voltage differential signaling) transmitter board converts the parallel display bus to a serialized, low voltage, differential signal bus in order to transmit the video signal to the LCD interface PCA.

7.5.2. Front Panel Touchscreen/Display Interface PCA

The front panel touchscreen/display interface PCA controls the various functions of the display and touchscreen. For driving the display it provides connection between the CPU video controller and the LCD display module. This PCA also contains:

- power supply circuitry for the LCD display module
- a USB hub that is used for communications with the touchscreen controller and the two front panel USB device ports
- the circuitry for powering the display backlight

7.6. SOFTWARE OPERATION

The Model T360 Gas Filter Correlation Carbon Dioxide Analyzer has a high performance, VortexX86-based microcomputer running Windows CE. Inside Windows CE, special software developed by Teledyne API interprets user commands via the various interfaces, performs procedures and tasks, stores data in the CPU's various memory devices and calculates the concentration of the sample gas.

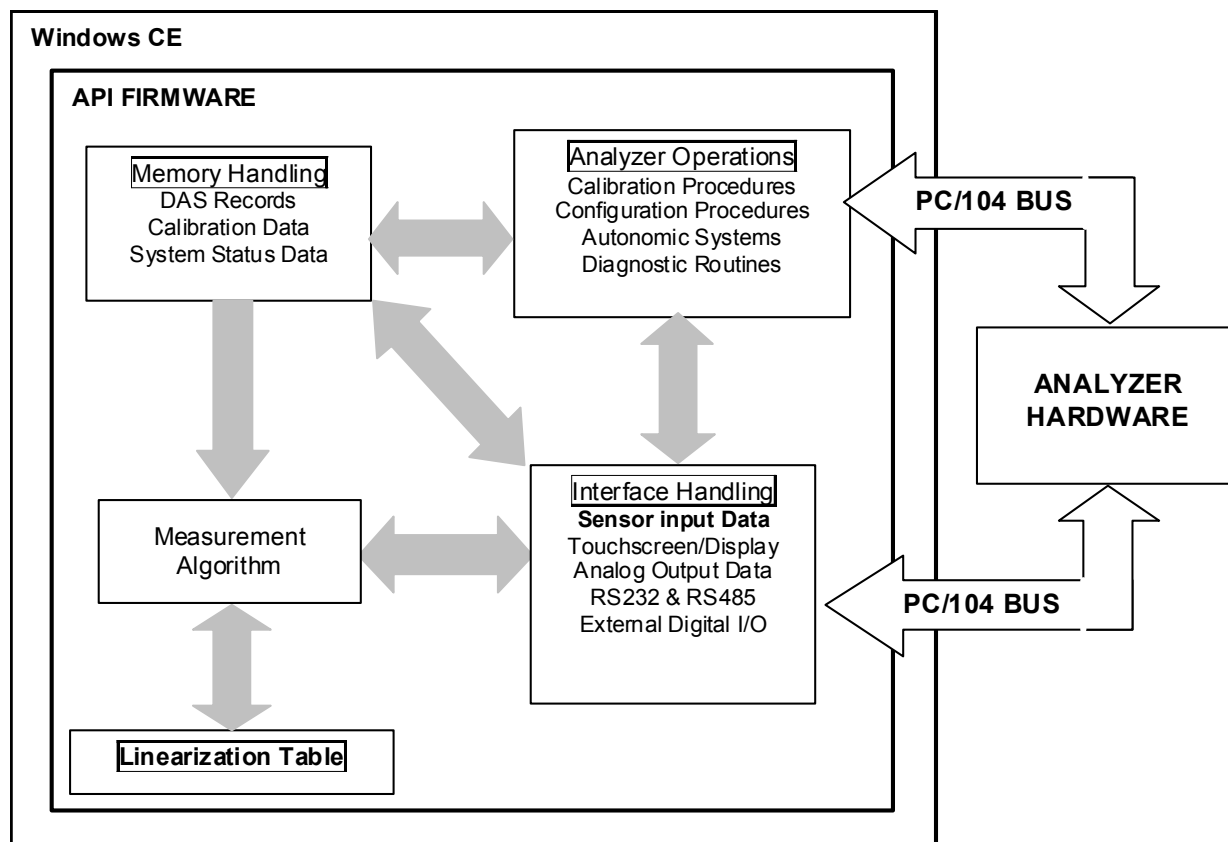

Figure 7-20: Basic Software Operation

7.6.1. Adaptive Filter

The T360 software processes the **CO₂ MEAS** and **CO₂ REF** signals, after they are digitized by the motherboard, through an adaptive filter built into the software. Unlike other analyzers that average the output signal over a fixed time period, the T360 averages over a set number of samples, where each sample is 0.2 seconds. This technique is known as boxcar averaging. During operation, the software automatically switches between two different length filters based on the conditions at hand. Once triggered, the short filter remains engaged for a fixed time period to prevent chattering.

During conditions of constant or nearly constant concentration the software, by default, computes an average of the last 750 samples, or approximately 150 seconds. This provides the calculation portion of the software with smooth, stable

readings. If a rapid change in concentration is detected the filter includes, by default, the last 48 samples, approximately 10 seconds of data, to allow the analyzer to more quickly respond. If necessary, these boxcar lengths can be changed between 1 and 1000 samples but with corresponding tradeoffs in rise time and signal-to-noise ratio (contact Technical Support for more information).

Two conditions must be simultaneously met to switch to the short filter. First the instantaneous concentration must exceed the average in the long filter by a fixed amount. Second the instantaneous concentration must exceed the average in the long filter by a portion, or percentage, of the average in the long filter.

7.6.2. Calibration - Slope and Offset

Calibration of the analyzer is performed exclusively in software.

During instrument calibration (see Calibration Section) the user enters expected values for zero and span via the front panel touchscreen and commands the instrument to make readings of calibrated sample gases for both levels. The readings taken are adjusted, linearized, and compared to the expected values. With this information the software computes values for instrument slope and offset and stores these values in memory for use in calculating the CO₂ concentration of the sample gas.

The instrument slope and offset values recorded during the last calibration can be viewed by pressing the following touchscreen button sequence:

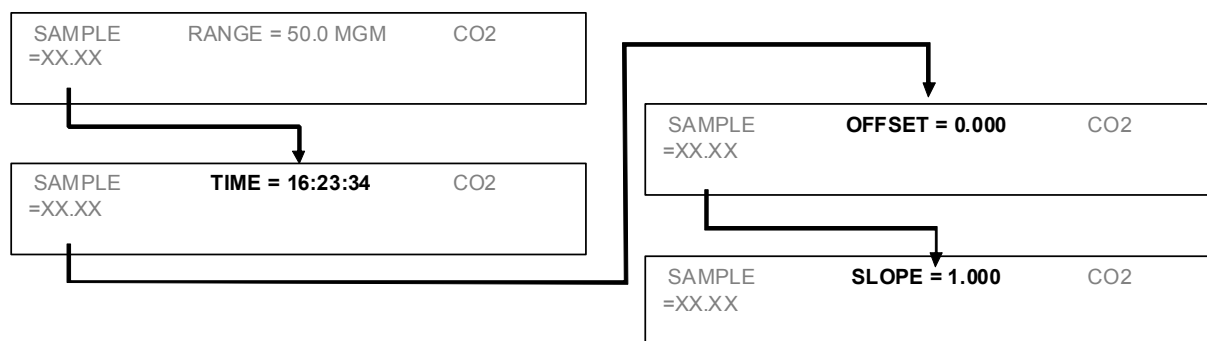

7.6.3. Measurement Algorithm

Once the IR photo-detector is signal is demodulated into **CO2 MEAS** and **CO2 REF** by the sync/demod board and converted to digital data by the motherboard the T360 analytical software calculates the ratio between **CO2 MEAS** and **CO2 REF**. This value is compared to a look-up table is used, with interpolation, to linearize the response of the instrument. The linearized concentration value is combined with calibration slope and offset values, then normalized for changes in sample gas pressure to produce the final CO₂ concentration. This is the value that is displayed on the instrument front panel display and is stored in memory by the analyzer's DAS system.

7.6.4. Temperature and Pressure Compensation

Changes in pressure can have a noticeable effect on the CO₂ concentration calculation. To account for this, the Model T360 software includes a feature which allows the instrument to compensation of the CO₂ calculations based on changes in ambient pressure.

The TPC feature multiplies the analyzer's CO₂ concentration by a factor which is based on the difference between the ambient pressure of the sample gas normalized to standard atmospheric pressure. As ambient pressure increases, the compensated CO₂ concentration is increased.

7.6.5. Internal Data Acquisition System (DAS)

The DAS is designed to implement predictive diagnostics that stores trending data for users to anticipate when an instrument will require service. Large amounts of data can be stored in non-volatile memory and retrieved in plain text format for further processing with common data analysis programs. The DAS has a consistent user interface in all Teledyne API analyzers. New data parameters and triggering events can be added to the instrument as needed.

Depending on the sampling frequency and the number of data parameters the DAS can store several months of data, which are retained even when the instrument is powered off or a new firmware is installed. The DAS permits users to access the data through the instrument's front panel or the remote interface. The latter can automatically download stored data for further processing. For information on using the DAS, refer to Section 4.7.

8. TROUBLESHOOTING AND SERVICE

This contains a variety of methods for identifying the source of performance problems with the analyzer. Also included in this are procedures that are used in repairing the instrument.



CAUTION

The operations outlined in this section are to be performed by qualified maintenance personnel only.



CAUTION

Risk of electrical shock. Disconnect power before performing the following operations.

8.1. GENERAL TROUBLESHOOTING HINTS

The analyzer has been designed so that problems can be rapidly detected, evaluated and repaired. During operation, the analyzer continuously performs self-check diagnostics and provides the ability to monitor the key operating parameters of the instrument without disturbing monitoring operations.

A systematic approach to troubleshooting will generally consist of the following four steps:

1. Note any **WARNING MESSAGES** and take corrective action as required.
2. Examine the values of all **TEST** functions and compare to factory values. Note any major deviations from the factory values and take correction action as required.
3. Use the internal electronic status LED's to determine whether the CPU and I²C buses are running, and if the sync/demodulator and relay board are operating properly. Verify that the DC power supplies are operating properly by checking the voltage test points on the relay board. Please note that the analyzer's DC power wiring is color-coded and these colors match the color of the corresponding test points on the relay board.
4. **SUSPECT A LEAK FIRST!** Data from Teledyne API's Technical Support department indicates that 50% of all problems are eventually traced to leaks in the pneumatic connections and gas lines of the analyzer itself, the source of zero air, span gases or sample gas delivery system.

Check for gas flow problems such as clogged or blocked internal/external gas lines, damaged seals, punctured gas lines, a damaged pump diaphragm, etc.

5. Follow the procedures defined in Section 8.5 for confirming that the analyzer's basic components are working (power supplies, CPU, relay board, sync/demod board, touchscreen/display, GFC wheel motor, etc.). See Figure 3-5 for general layout of components and sub-assemblies in the analyzer. See the wiring list and diagram in Appendix D of this manual.

8.1.1. Interpreting WARNING Messages

The most common and/or serious instrument failures will result in a warning message being displayed on the front panel. Table 8-1 lists warning messages, along with their meaning and recommended corrective action.

It should be noted that if more than two or three warning messages occur at the same time, it is often an indication that some fundamental analyzer sub-system (power supply, relay board, motherboard) has failed rather than indication of the specific failures referenced by the warnings. In this case, it is recommended that proper operation of power supplies (see Section 8.5.2), the relay board (see Section 8.5.6), and the A/D Board (see Section 8.5.8.1) be confirmed before addressing the specific warning messages.

The analyzer will alert the user that a Warning message is active by flashing the FAULT LED and displaying the Warning message in the Param field along with the CLR button (press to clear Warning message). The MSG button displays if there is more than one warning in queue or if you are in the TEST menu and have not yet cleared the message. The following display/touchscreen examples provide an illustration of each:

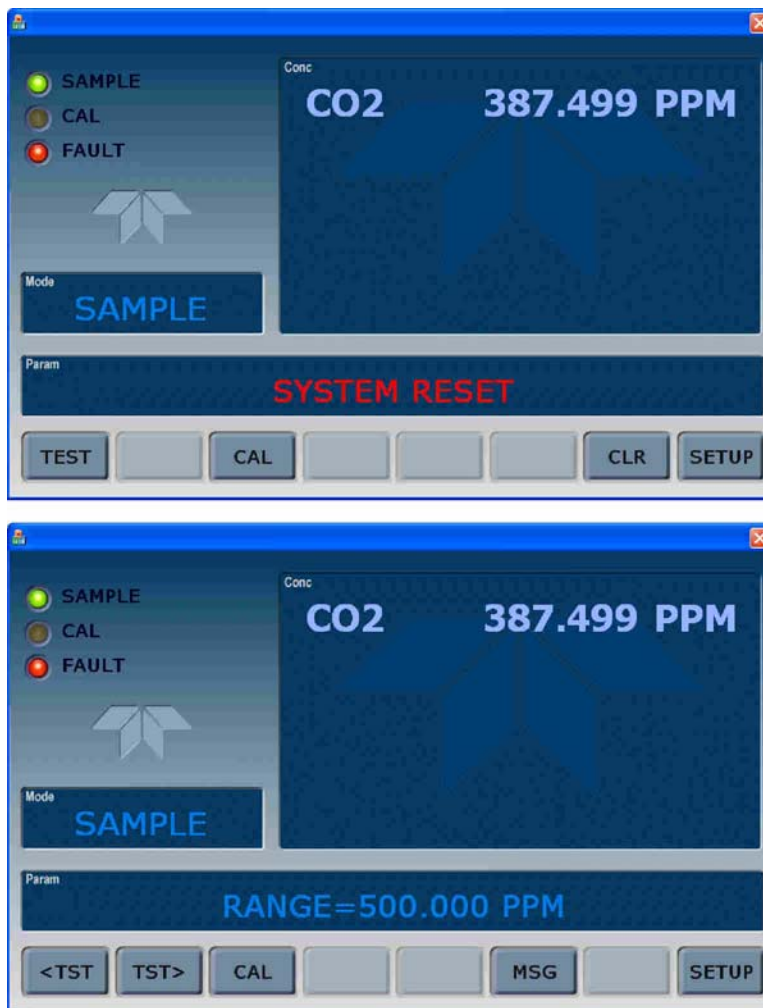

The analyzer will also alert the user via the Serial I/O COM port(s) and cause the FAULT LED on the front panel to blink.

To view or clear the various warning messages press:

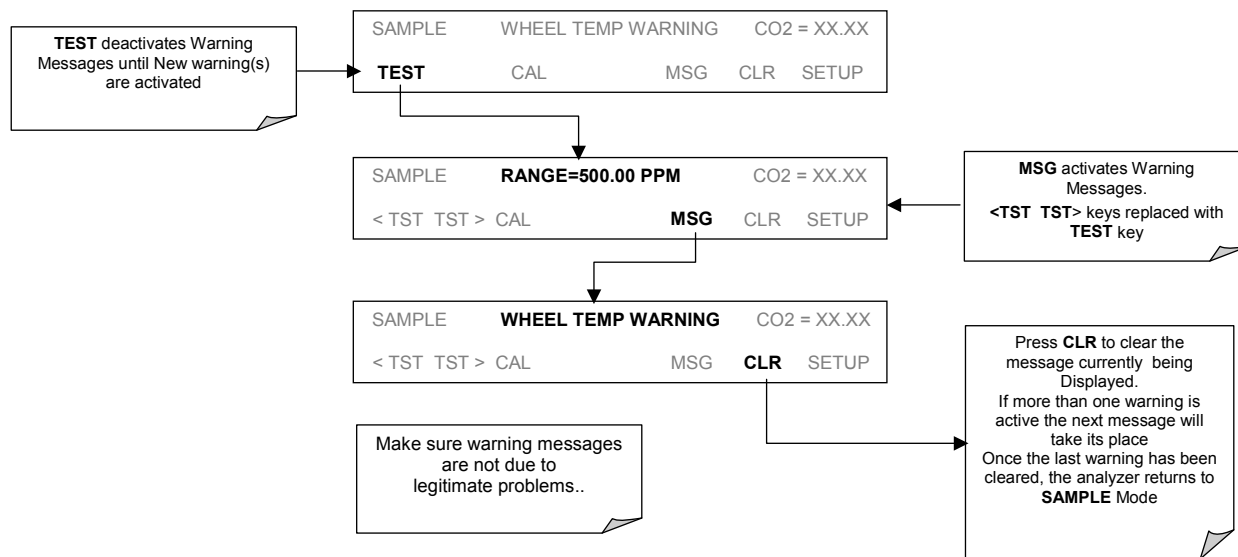

Figure 8-1: Viewing and Clearing Warning Messages

Table 8-1: Warning Messages - Indicated Failures

WARNING MESSAGE	FAULT CONDITION	POSSIBLE CAUSES
BENCH TEMP WARNING	The optical bench temp is controlled at 48 ± 2 °C.	Bad bench heater Bad bench temperature sensor Bad relay controlling the bench heater Entire relay board is malfunctioning I ² C bus malfunction
BOX TEMP WARNING	Box Temp is < 5 °C or > 48 °C.	NOTE: Box temperature typically runs ~7°c warmer than ambient temperature. Poor/blocked ventilation to the analyzer. Stopped exhaust-fan Ambient temperature outside of specified range
CANNOT DYN SPAN	Dynamic Span operation failed	Measured concentration value is too high or low. Concentration slope value to high or too low
CANNOT DYN ZERO	Dynamic Zero operation failed	Measured concentration value is too high. Concentration offset value to high.
CONFIG INITIALIZED	Configuration and Calibration data reset to original Factory state.	Failed disk on chip User erased data
CONC ALRM1 WARNING	Concentration alarm 1 is enabled and the measured CO ₂ level is ≥ the set point.	
CONC ALRM2 WARNING	Concentration alarm 2 is enabled and the measured CO ₂ level is ≥ the set point.	
DATA INITIALIZED	Data Storage in DAS was erased	Failed disk on chip User cleared data
PHOTO TEMP WARNING	PHT DRIVE is >4800 mVDC	Failed IR photo-detector Failed sync/demod board IR photo-detector improperly attached to the sample chamber Bench temp too high.
REAR BOARD NOT DET	Motherboard not detected on power up.	Warning only appears on serial i/o com port(s) Front panel display will be frozen, blank or will not respond. Massive failure of mother board
RELAY BOARD WARN	The CPU cannot communicate with the Relay Board.	I ² C bus failure Failed relay board Loose connectors/wiring
SAMPLE FLOW WARN	Sample flow rate is < 500 cc/min or > 1000 cc/min.	Failed sample pump Blocked sample inlet/gas line Dirty particulate filter Leak downstream of critical flow orifice Failed flow sensor/circuitry
SAMPLE PRES WARN	Sample Pressure is <10 in-Hg or > 35 in-Hg Normally 29.92 in-Hg at sea level decreasing at 1 in-Hg per 1000 ft of altitude (with no flow – pump disconnected).	If sample pressure is < 10 in-hg: <ul style="list-style-type: none"> o Blocked particulate filter o Blocked sample inlet/gas line o Failed pressure sensor/circuitry If sample pressure is > 35 in-hg: <ul style="list-style-type: none"> o Pressurized sample gas. Install vent o Blocked vent line on pressurized sample/zero/span gas supply o Bad pressure sensor/circuitry
SAMPLE TEMP WARN	Sample temperature is < 10°C or > 100°C.	Ambient temperature outside of specified range Failed bench heater Failed bench temperature sensor Relay controlling the bench heater Failed relay board I ² C bus

WARNING MESSAGE	FAULT CONDITION	POSSIBLE CAUSES
SOURCE WARNING	Occurs when CO ₂ Ref is <1250 mVDC or >4950 mVDC. Either of these conditions will result in an invalid M/R ratio.	GFC wheel stopped Failed sync/demod board If status LED's on the sync/demod board <u>ARE</u> flashing the cause is most likely a failed: IR source Relay board I ² C bus IR photo-detector
SYSTEM RESET	The computer has rebooted.	This message occurs at power on. If you have not cycled the power on your instrument: o Failed +5 VDC power, o Fatal error caused software to restart o Loose connector/wiring
WHEEL TEMP WARNING	The filter wheel temperature is controlled at 68 ± 2 °C	Blocked cooling vents below GFC Assembly. Make sure that adequate clear space beneath the analyzer. Analyzer's top cover removed Wheel heater Wheel temperature sensor Relay controlling the wheel heater Entire relay board I ² C bus

8.1.2. Fault Diagnosis with TEST Functions

Besides being useful as predictive diagnostic tools, the test functions viewable from the front panel can be used to isolate and identify many operational problems when combined with a thorough understanding of the analyzer's principles of operation (see Section 7).

The acceptable ranges for these test functions are listed in the "Nominal Range" column of the analyzer *Final Test and Validation Data Sheet* (p/n 04307) shipped with the instrument. Values outside these acceptable ranges indicate a failure of one or more of the analyzer's subsystems. Functions whose values are still within the acceptable range but have significantly changed from the measurement recorded on the factory data sheet may also indicate a failure. A worksheet has been provided in Appendix C to assist in recording the value of these test functions.

Table 8-2 contains some of the more common causes for these values to be out of range.

Table 8-2: Test Functions - Indicated Failures

TEST FUNCTIONS	INDICATED FAILURE(S)
TIME	Time of day clock is too fast or slow: To adjust See Section 4.10. Battery in clock chip on CPU board may be dead.
RANGE	Incorrectly configured measurement range(s) could cause response problems with a Data logger or chart recorder attached to one of the analog outputs. <ul style="list-style-type: none"> If the Range selected is too small, the recording device will over range. If the Range is too big, the device will show minimal or no apparent change in readings.
STABIL	Indicates noise level of instrument or CO ₂ concentration of sample gas (see Section 8.4.2 for causes).
CO2 MEAS & CO2 REF	<ul style="list-style-type: none"> If the value displayed is too high the IR Source has become brighter: <ul style="list-style-type: none"> Adjust the variable gain potentiometer on the sync/demod board If the value displayed is too low or constantly changing and the CO₂ REF is OK: <ul style="list-style-type: none"> Failed multiplexer on the motherboard Failed sync/demod board Loose connector or wiring on sync/demod board Flow of purge gas to the GFC wheel housing may have stopped If the value displayed is too low or constantly changing and the CO₂ REF is <u>BAD</u>: <ul style="list-style-type: none"> GFC wheel stopped or rotation is too slow Failed sync/demod board IR source Failed IR source Failed relay board Failed I²C bus Failed IR photo-detector
MR RATIO	<ul style="list-style-type: none"> When the analyzer is sampling zero air and the ratio is too low: <ul style="list-style-type: none"> The reference cell of the GFC wheel is contaminated or leaking. The alignment between the GFC wheel and the segment sensor, the M/R sensor or both is incorrect. Failed sync/demod board Flow of purge gas to the GFC wheel housing may have stopped When the analyzer is sampling zero air and the ratio is too high: <ul style="list-style-type: none"> Zero air is contaminated Failed IR photo-detector
PRES	See Table 8-1 for SAMPLE PRES WARN
SAMPLE FL	Check for gas flow problems. see Section 8.2
SAMPLE TEMP	SAMPLE TEMP should be close to BENCH TEMP . Temperatures outside of the specified range or oscillating temperatures are cause for concern
BENCH TEMP	Bench temp control improves instrument noise, stability and drift. Temperatures outside of the specified range or oscillating temperatures are cause for concern. See Table 8-1 for BENCH TEMP WARNING
WHEEL TEMP	Wheel temp control improves instrument noise, stability and drift. Outside of set point or oscillating temperatures are cause for concern. See Table 8-1 for WHEEL TEMP WARNING
BOX TEMP	If the box temperature is out of range, check fan in the power supply module. Areas to the side and rear of instrument should allow adequate ventilation. See Table 8-1 for BOX TEMP WARNING .
PHT DRIVE	If this drive voltage is out of range it may indicate one of several problems: <ul style="list-style-type: none"> A poor mechanical connection between the various components in inside the detector housing An electronic failure of the IR Photo-Detector's built-in cooling circuitry, or; A temperature problem inside the analyzer chassis. In this case other temperature warnings would also be active such as BENCH TEMP WARNING or BOX TEMP WARNING.

TEST FUNCTIONS	INDICATED FAILURE(S)
SLOPE	Values outside range indicate: <ul style="list-style-type: none"> • Contamination of the zero air or span gas supply • Instrument is miss-calibrated • Blocked gas flow • Contaminated or leaking GFC wheel (either chamber) • Faulty IR photo-detector • Faulty sample faulty IR photo-detector pressure sensor (P1) or circuitry • Invalid M/R ratio (see above) • Bad/incorrect span gas concentration due.
OFFSET	Values outside range indicate: <ul style="list-style-type: none"> • Contamination of the zero air supply • Contaminated or leaking GFC wheel (either chamber) • Faulty IR photo-detector

8.1.3. Using the Diagnostic Signal I/O Function

The Signal I/O parameters found under the DIAG Menu (see Section 4.13.2 and Appendix A) combined with a thorough understanding of the instrument’s principles of operation (Section 7) are useful for troubleshooting in three ways:

- The technician can view the raw, unprocessed signal level of the analyzer’s critical inputs and outputs.
- All of the components and functions that are normally under algorithmic control of the CPU can be manually exercised.
- The technician can directly control the signal level of the Analog and Digital Output signals.

This allows the technician to systematically observe the effect of directly controlling these signals on the operation of the analyzer. Below in Figure 8-2 is an example of how to use the signal I/O menu to view the raw voltage of an input signal or to control the state of an output voltage or control signal. The specific parameter will vary depending on the situation.

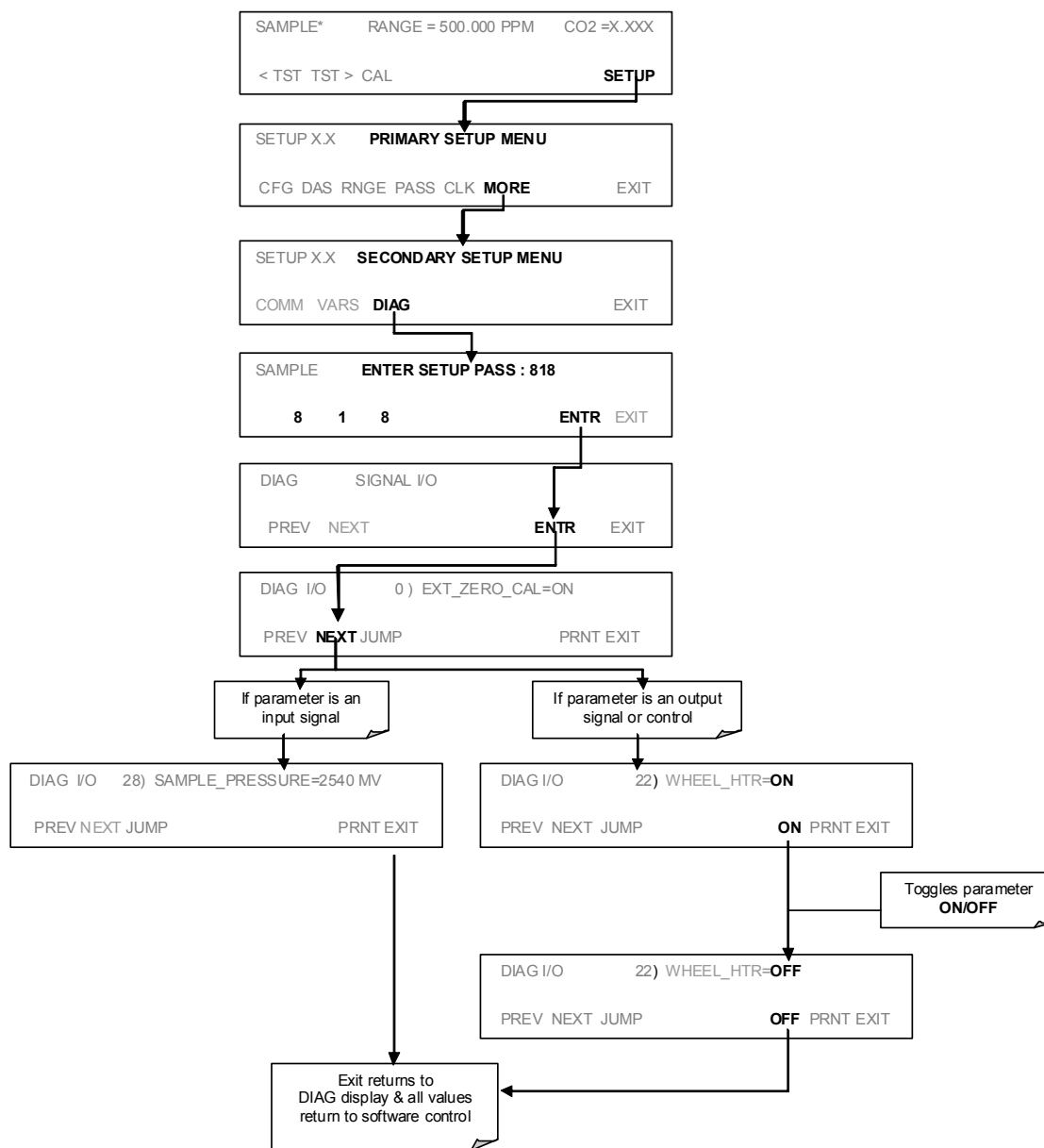

Figure 8-2: Example of Signal I/O Function

8.1.4. Internal Electronic Status LEDs

Several LED's are located inside the instrument to assist in determining if the analyzer's CPU, I²C bus and relay board, GFC wheel and the sync/demodulator board are functioning properly.

8.1.4.1. CPU STATUS INDICATOR

DS5, a red LED, that is located on upper portion of the motherboard, just to the right of the CPU board, flashes when the CPU is running the main program loop. After power-up, approximately 30 to 60 seconds, DS5 should flash on and off. If characters are written to the front panel display but DS5 does not flash then the program files have become corrupted. If after 30 – 60 seconds neither the DS5 is flashing or no characters have been written to the front panel display then the CPU is bad and must be replaced.

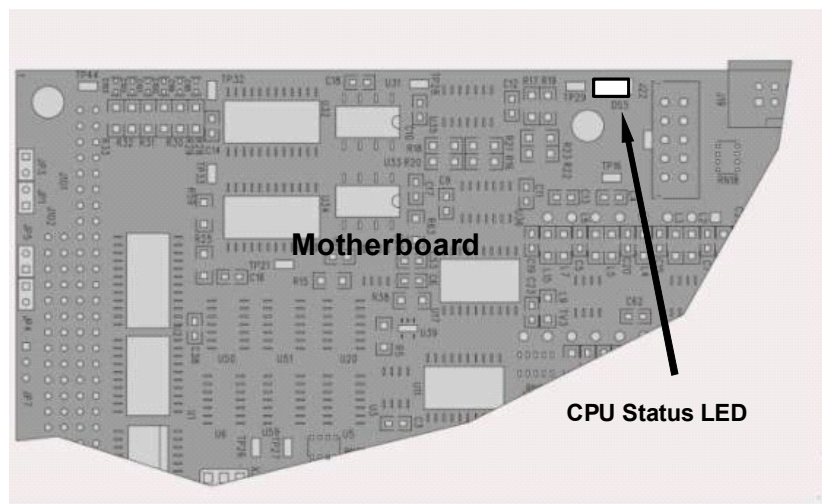

Figure 8-3: CPU Status Indicator

8.1.4.2. SYNC DEMODULATOR STATUS LED'S

Two LEDs located on the Sync/Demod Board and are there to make it obvious that the GFC Wheel is spinning and the synchronization signals are present:

Table 8-3: Sync/Demod Board Status Failure Indications

LED	FUNCTION	FAULT STATUS	INDICATED FAILURE(S)
D1	M/R Sensor Status (Flashes slowly)	LED is stuck ON or OFF	GFC Wheel is not turning M/R Sensor on Opto-Pickup Board failed Sync/Demod Board failed JP 4 Connector/Wiring faulty Failed/Faulty +5 VDC Power Supply (PS1)
D2	Segment Sensor Status (Flashes quickly)	LED is stuck ON or OFF	GFC Wheel is not turning Segment Sensor on Opto-Pickup Board failed Sync/Demod Board failed JP 4 Connector/Wiring faulty Failed/Faulty +5 VDC Power Supply (PS1)

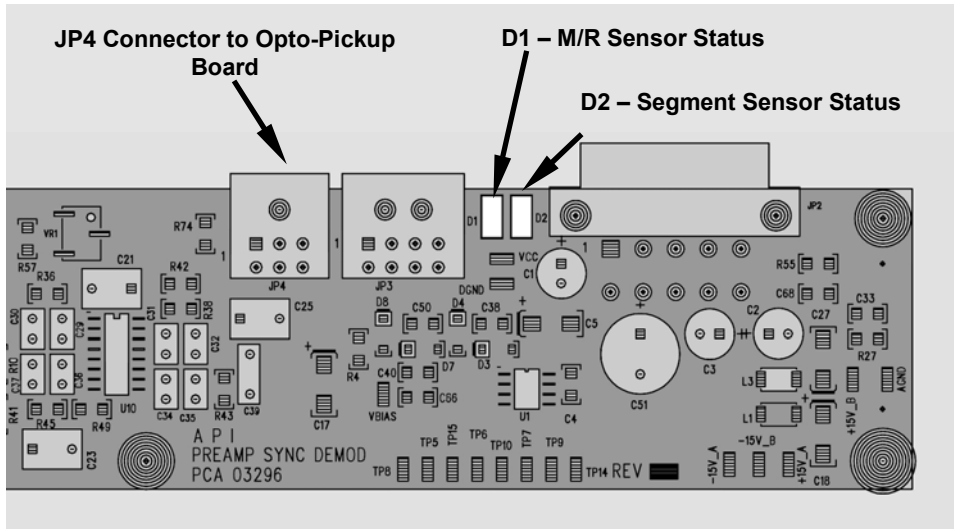

Figure 8-4: Sync/Demod Board Status LED Locations

8.1.4.3. RELAY BOARD STATUS LEDs

There are eight LEDs located on the Relay Board. The most important of which is D1, which indicates the health of the I²C bus. If D1 is blinking, the other faults LEDs (Table 8-5) can be used in conjunction with **DIAG** menu signal I/O to identify hardware failures of the relays and switches on the relay (See Section 4.13.2 and Appendix D).

Table 8-4: I2C Status LED Failure Indications

LED	FUNCTION	FAULT STATUS	INDICATED FAILURE(S)
D1 (Red)	I ² C bus Health (Watchdog Circuit)	Continuously ON or Continuously OFF	Failed/Halted CPU Faulty Motherboard, or Relay Board Faulty Connectors/Wiring to/from Relay Board Failed/Faulty +5 VDC Power Supply (PS1)

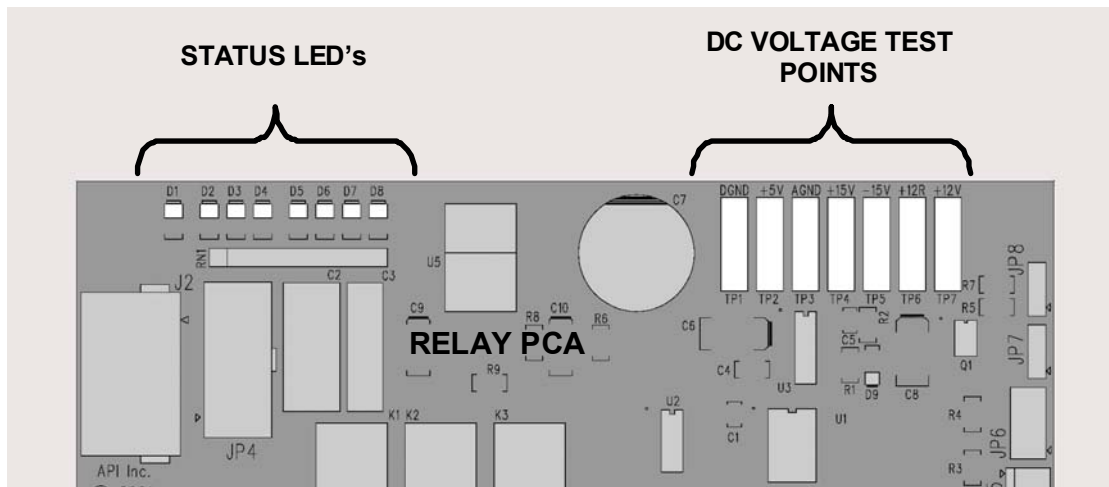

Figure 8-5: Relay Board Status LEDs

Table 8-5: Relay Board Status LED Failure Indications

LED	FUNCTION	SIGNAL I/O PARAMETER		DIAGNOSTIC TECHNIQUE
		ACTIVATED BY	VIEW RESULT	
D2 Yellow	WHEEL HEATER	WHEEL_HEATER	WHEEL_TEMP	Voltage displayed should change. If not: Failed Heater Faulty Temperature Sensor Failed AC Relay Faulty Connectors/Wiring
D3 Yellow	BENCH HEATER	BENCH_HEATER	BENCH_TEMP	Voltage displayed should change. If not: Failed Heater Faulty Temperature Sensor Failed AC Relay Faulty Connectors/Wiring
D4 Yellow	SPARE	N/A	N/A	N/A
D5 Green	SAMPLE/CAL GAS VALVE OPTION	CAL_VALVE	N/A	Sample/Cal Valve should audibly change states. If not: Failed Valve Failed Relay Drive IC on Relay Board Failed Relay Board Faulty +12 VDC Supply (PS2) Faulty Connectors/Wiring
D6 Green	ZERO/SPAN GAS VALVE OPTION	SPAN_VALVE	N/A	Zero/Span Valve should audibly change states. If not: Failed Valve Failed Relay Drive IC on Relay Board Failed Relay Board Faulty +12 VDC Supply (PS2) Faulty Connectors/Wiring
D7 Green	SHUTOFF VALVE OPTION	SHUTOFF_VALVE	N/A	Shutoff Valve should audibly change states. If not: Failed Valve Failed Relay Drive IC on Relay Board Failed Relay Board Faulty +12 VDC Supply (PS2) Faulty Connectors/Wiring
D8 Green	IR SOURCE	IR_SOURCE	CO ₂ _MEASURE	Voltage displayed should change. If not: Failed IR Source Faulty +12 VDC Supply (PS2) Failed Relay Board Failed IR Photo-Detector Failed Sync/Demod Board Faulty Connectors/Wiring

8.2. GAS FLOW PROBLEMS

The T360 has two main gas flow paths, the sample gas flow path and the GFC purge gas flow path. Both are controlled by a critical flow orifice. Only the sample gas path is measured and reported. When the IZS or zero/span valve options are installed, there are several subsidiary paths but none of those are displayed on the front panel or stored by the DAS.

With the O₂ sensor option installed, third gas flow controlled with a critical flow orifice is added, but this flow is not measured or reported.

In general, flow problems can be divided into three categories:

- Flow is too high
- Flow is greater than zero, but is too low, and/or unstable
- Flow is zero (no flow)

When troubleshooting flow problems, it is crucial to confirm the actual flow rate without relying on the analyzer's flow display. The use of an independent, external flow meter to perform a flow check as described in Section 6.3.4 is essential. If this test shows the flow to be correct, check the pressure sensors as described in Section 8.5.7.5.

The flow diagrams provided in this manual depicting the T360 in its standard configuration and with options installed can help in trouble-shooting flow problems. For your convenience they are collected here.

8.2.1. T360 Internal Gas Flow Diagrams

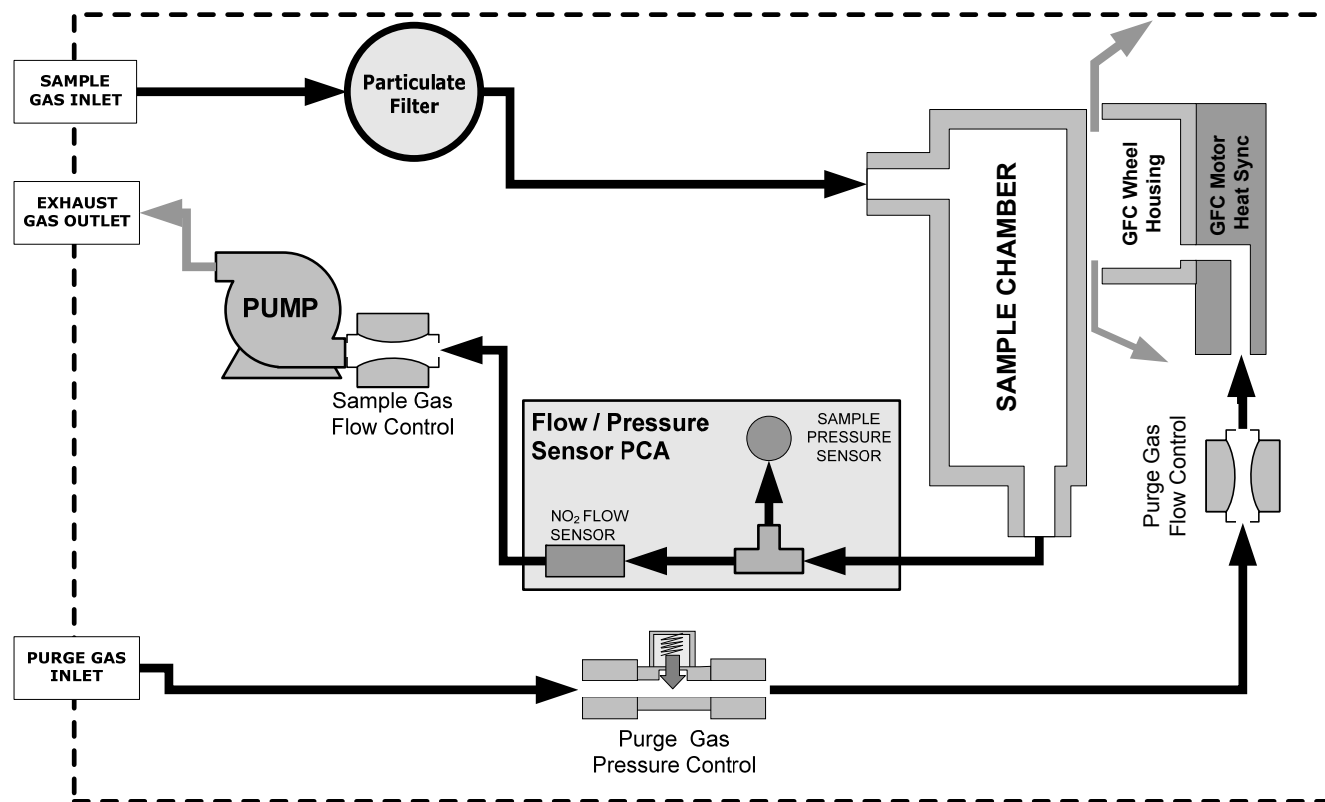

Figure 8-6: T360 – Basic Internal Gas Flow

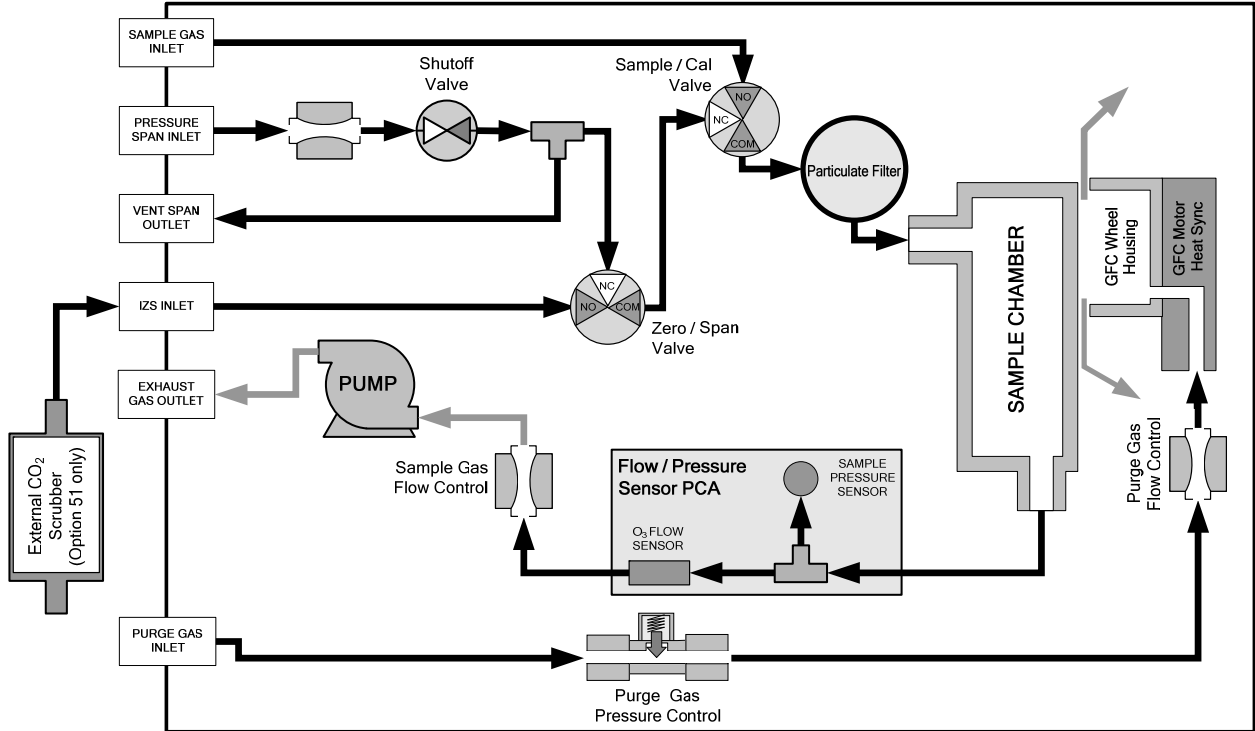

Figure 8-7: Internal Pneumatic Flow – Ambient Zero/Pressurized Span Valves

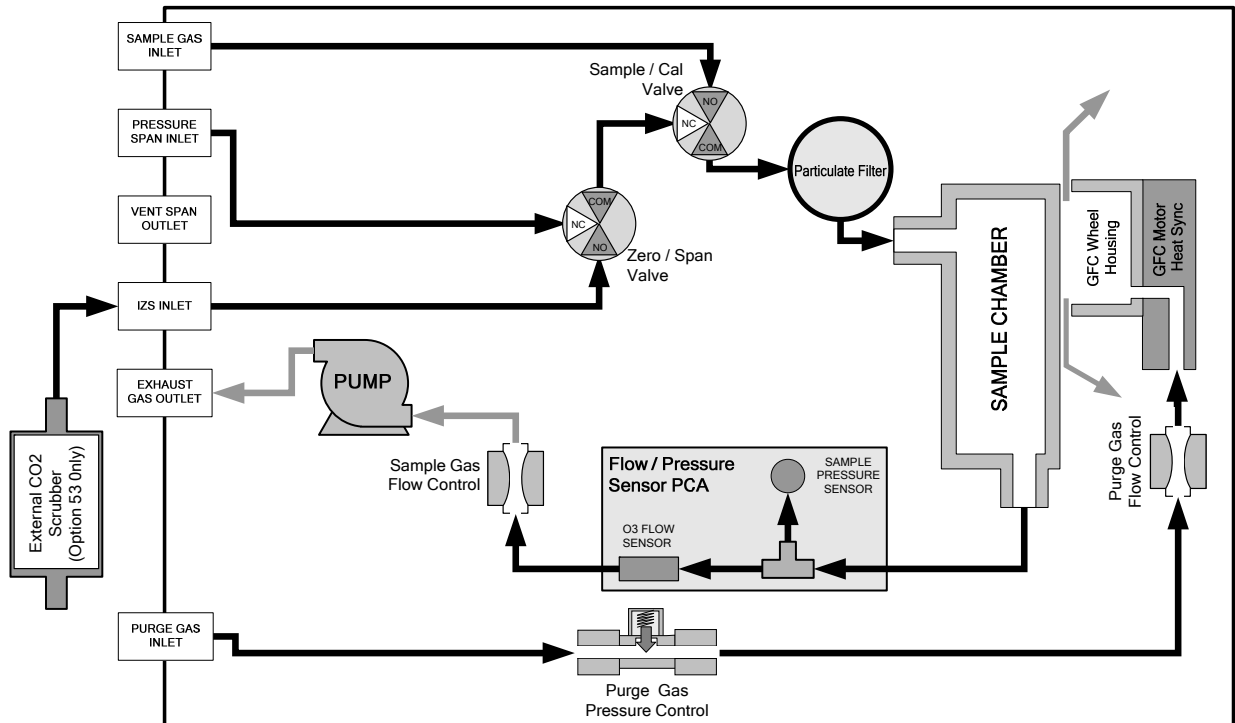

Figure 8-8: Internal Pneumatic Flow – Ambient Zero/Ambient Span

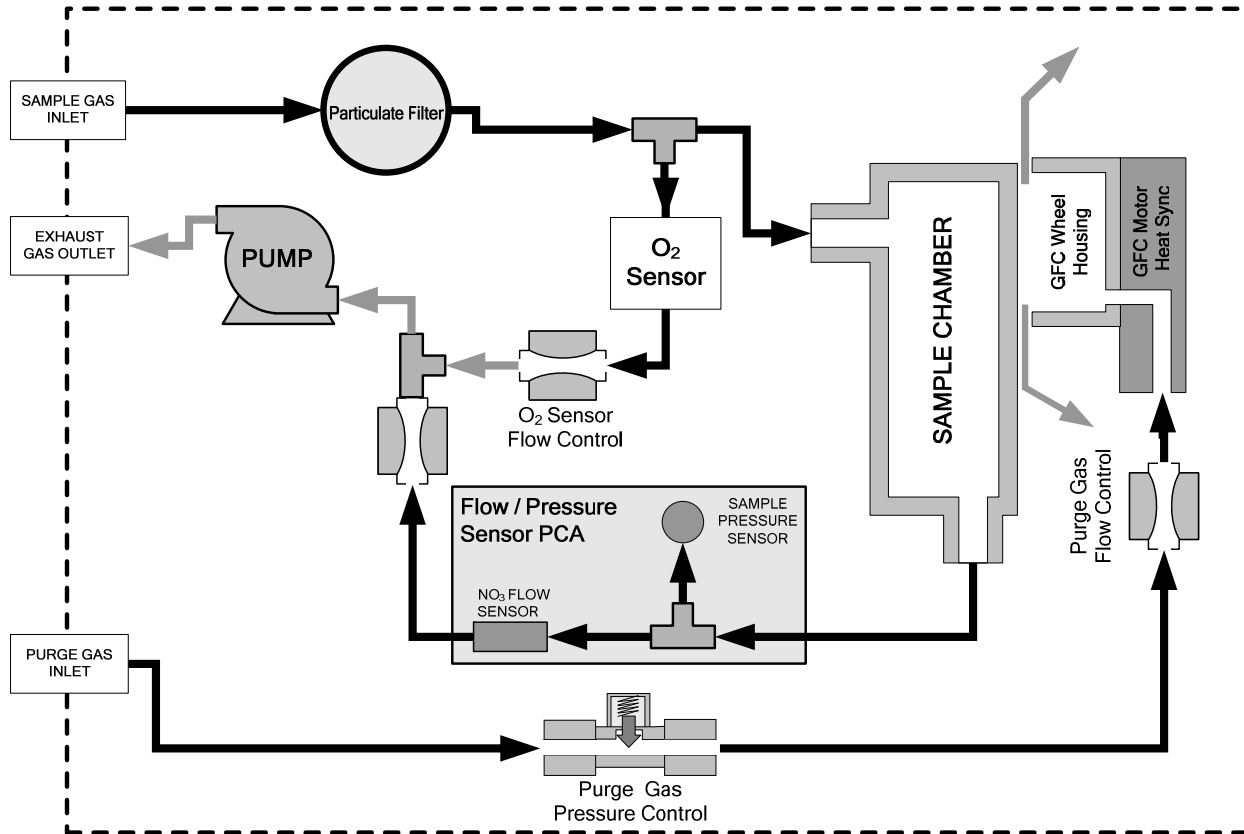

Figure 8-9: T360 – Internal Pneumatics with O₂ Sensor Option 65A

8.2.2. Typical Sample Gas Flow Problems

8.2.2.1. FLOW IS ZERO

The unit displays a **SAMPLE FLOW** warning message on the front panel display or the **SAMPLE FLOW** test function reports a zero or very low flow rate.

Confirm that the sample pump is operating (turning). If not, use an AC voltmeter to make sure that power is being supplied to the pump. If no power is present at the electrical leads of the pump.

1. If AC power is being supplied to the pump, but it is not turning, replace the pump.
2. If the pump is operating but the unit reports no gas flow, perform a flow check as described in Section 6.3.4.
3. If no independent flow meter is available:
 - Disconnect the gas lines from both the sample inlet and the exhaust outlet on the rear panel of the instrument.
 - Make sure that the unit is in basic **SAMPLE Mode**.
 - Place a finger over an Exhaust outlet on the rear panel of the instrument.

- If gas is flowing through the analyzer, you will feel pulses of air being expelled from the Exhaust outlet.
4. If gas flows through the instrument when it is disconnected from its sources of zero air, span gas or sample gas, the flow problem is most likely not internal to the analyzer. Check to make sure that:
- All calibrators/generators are turned on and working correctly.
 - Gas bottles are not empty or low.
 - Valves, regulators and gas lines are not clogged or dirty.

8.2.2.2. LOW FLOW

- Check if the pump diaphragm is in good condition. If not, rebuild the pump (see Section 6.3.2). Check the Spare Parts List for information of pump rebuild kits.
- Check for leaks as described in Section 6.3.3. Repair the leaking fitting, line or valve and re-check.
- Check for the sample filter and the orifice filter for dirt. Replace filters (see Sections 6.3.1 and 8.6.1 respectively).
- Check for partially plugged pneumatic lines, orifices, or valves. Clean or replace them.
- If an IZS option is installed in the instrument, press **CALZ** and **CALS**. If the flow increases then suspect a bad sample/cal valve.

8.2.2.3. HIGH FLOW

The most common cause of high flow is a leak in the sample flow control assembly or between there and the pump. If no leaks or loose connections are found in the fittings or the gas line between the orifice and the pump, rebuild/clean the sample flow control assembly as described in Section 8.6.1.

8.2.2.4. DISPLAYED FLOW = “XXXX”

This warning means that there is inadequate gas flow. There are four conditions that might cause this:

- A leak upstream or downstream of the flow sensor
- A flow obstruction upstream or downstream of the flow sensor
- Bad Flow Sensor Board
- Bad pump

To determine which case it is, view the sample pressure and sample flow functions via the front panel. If the sample pressure is reading abnormally low, then the cause is likely a flow obstruction upstream of the flow sensor. First, check the sample filter and make sure it is not plugged and then systematically check all the other components upstream of the orifice to ensure that they are not obstructed.

If the sample pressure is reading normal but the sample flow is reading low then it is likely that the pump diaphragm is worn or there is an obstruction downstream of the flow sensor.

8.2.2.5. ACTUAL FLOW DOES NOT MATCH DISPLAYED FLOW

If the actual flow measured does not match the displayed flow, but is within the limits of 720-880 cc/min, adjust the calibration of the flow measurement as described in Section 4.13.8.

8.2.2.6. SAMPLE PUMP

The sample pump should start immediately after the front panel power switch is turned ON. With the Sample Inlet plugged, the test function **PRES** should read about 10²-Hg for a pump in good condition. Readings above 10² Hg indicate that the pump needs rebuilding. If the test function **SAMP FL** is greater than 10 cm³/min there is a leak in the pneumatic lines.

8.2.3. Poor or Stopped Flow of Purge Gas

If sufficient purge gas is not supplied to the GFC wheel housing, cyclical fluctuations in readings at zero or low CO₂ concentrations, such as < 100 ppm, may occur. These fluctuations are the result of changes in the CO₂ concentration of the ambient atmosphere throughout the course of the day and night. In isolated areas with relatively few people working nearby the ambient CO₂ concentration will fall during the day and rise during the night as rate of photosynthesis of the plants in the surrounding area decreases and increases. In a lab environment with a relatively high human occupancy the ambient CO₂ concentration will increase during those parts of the day when the highest number of workers are present. If the GFC wheel housing is allowed to fill with ambient air, these natural, diurnal fluctuations might be detected by the instrument and cause it's in its calculation of the CO₂ concentration of the sample gas to drift.

Another possible symptom of poor or stopped purge gas flow would be the inability to measure zero concentrations accurately at the end of a work day on a system that was calibrated at the beginning of a workday. Although this could also be due to local fluctuations in ambient CO₂ concentration during the day.

8.3. CALIBRATION PROBLEMS

8.3.1. Miscalibrated

There are several symptoms that can be caused by the analyzer being miscalibrated. This condition is indicated by out of range Slopes and Offsets as displayed through the test functions and is frequently caused by the following:

- **BAD SPAN GAS.** This can cause a large error in the slope and a small error in the offset. Delivered from the factory, the T360's slope is within $\pm 15\%$ of nominal. Bad span gas will cause the analyzer to be calibrated to the wrong value. If in doubt have the span gas checked by an independent lab.
- **CONTAMINATED ZERO GAS.** Excess H₂O can cause a positive or negative offset and will indirectly affect the slope.
- **Dilution calibrator not set up correctly or is malfunctioning.** This will also cause the slope, but not the zero, to be incorrect. Again the analyzer is being calibrated to the wrong value.
- **Too many analyzers on the manifold.** This can cause either a slope or offset error because ambient gas with its pollutants will dilute the zero or span gas.

8.3.2. Non-Repeatable Zero and Span

As stated earlier, leaks both in the T360 and in the external system are a common source of unstable and non-repeatable readings.

1. Check for leaks in the pneumatic systems as described in Section 6.3.3. Don't forget to consider pneumatic components in the gas delivery system outside the T360. Such as:
 - A change in zero air source such as ambient air leaking into zero air line, or;
 - A change in the span gas concentration due to zero air or ambient air leaking into the span gas line.
2. Once the instrument passes a leak check, do a flow check (see Section 6.3.4) to make sure adequate sample is being delivered to the sensor assembly.
3. A failing IR photo-detector may be at fault. Check the **CO₂ MEAS** and **CO₂ REF** test functions via the front panel display to make sure the signal levels are in the normal range (see Appendix A) and are quiet.
4. Confirm the sample pressure, wheel temperature, bench temperature, and sample flow readings are correct and have steady readings.
5. Disconnect the exhaust line from the optical bench near the rear of the instrument and plug this line into the **SAMPLE** inlet creating a pneumatic loop. The CO₂ concentration (either zero or span) now must be constant. If readings become quiet, the problem is in the external pneumatics supplies for sample gas, span gas or zero air.
6. If pressurized span gas is being used with a zero/span valve option, make sure that the venting is adequate (see Sections 3.1 and 3.6.2).
7. If it is the zero point that is non-repeatable, and if that non-repeatability seems to only occur at a certain time of day, such as when worker occupancy is highest or lowest, make sure the flow of purge gas to the GFC wheel housing has not stopped (see Sections 8.2.3 and 8.5.7.3 for more information).

8.3.3. Inability to Span – Touchscreen SPAN Button Not Visible

1. Confirm that the carbon dioxide span gas source is accurate; this can be done by switching between two span-gas tanks. If the CO₂ concentration is different, there is a problem with one of the tanks.
2. Check for leaks in the pneumatic systems as described in Section 6.3.3.
3. Make sure that the expected span gas concentration entered into the instrument during calibration is the correct span gas concentration and not too different from expected span value. This can be viewed via the **RNGE** Menu (see Section 4.8).
4. Check to make sure that there is no ambient air or zero air leaking into span gas line.

8.3.4. Inability to Zero – Touchscreen ZERO Button Not Visible

1. Confirm that there is a good source of zero air. Dilute a tank of span gas with the same amount of zero air from two different sources. If the CO₂ Concentration of the two measurements is different, there is a problem with one of the sources of zero air.
2. Check for leaks in the pneumatic systems as described in Section 6.3.3.
3. If the analyzer has had zero/span valve options, the CO₂ scrubber may need maintenance.
4. Check to make sure that there is no ambient air leaking into zero air line.

8.4. OTHER PERFORMANCE PROBLEMS

Dynamic problems (i.e. problems which only manifest themselves when the analyzer is monitoring sample gas) can be the most difficult and time consuming to isolate and resolve. The following provides an itemized list of the most common dynamic problems with recommended troubleshooting checks and corrective actions.

8.4.1. Temperature Problems

Individual control loops are used to maintain the set point of the absorption bench, filter wheel, and IR photo-detector temperatures. If any of these temperatures are out of range or are poorly controlled, the T360 will perform poorly.

8.4.1.1. BOX OR SAMPLE TEMPERATURE

Box Temperature

The box temperature sensor is mounted to the motherboard and cannot be disconnected to check its resistance. Rather check the **BOX TEMP** signal using the **SIGNAL I/O** function under the **DIAG** Menu (See Section 8.1.3). This parameter will vary with ambient temperature, but at $\sim 30^{\circ}\text{C}$ ($6\text{-}7^{\circ}$ above room temperature) the signal should be ~ 1450 mV.

Sample Temperature

The Sample Temperature should closely track the bench temperature. If it does not, locate the sensor, which is located at the midpoint of the optical bench in a brass fitting. Unplug the connector labeled "Sample", and measure the resistance of the thermistor; at room temperature (25°C) it should be $\sim 30\text{K}$ Ohms, at operating temperature, 48°C , it should be $\sim 12\text{K}$ Ohms

8.4.1.2. BENCH TEMPERATURE

There are three possible failures that could cause the Bench temperature to be incorrect.



WARNING:

HAZARDOUS VOLTAGES ARE PRESENT DURING THIS TEST

1. The heater mounted to the bottom of the Absorption bench is electrically shorted or open. Check the resistance of the two heater elements by measuring between pin 2 and 4 (~ 76 Ohms), and pin 3 and 4 (~ 330 Ohms), of the white five-pin connector just below the sample temperature sensor on the Bench (pin 1 is the pointed end).
2. Assuming that the I^2C bus is working and that there is no other failure with the relay board, the solid-state relay (K2) on the relay board may have failed.

Using the **BENCH_HEATER** parameter under the signal I/O function, as described above, turn on and off K2 (D3 on the relay board should illuminate as the heater is turned on). Check the AC voltage present between pin 2 and 4, for a 100 or 115 VAC model, and pins 3 and 4, for a 220-240 VAC model.

3. If the relay has failed there should be no change in the voltage across pins 2 and 4 or 3 and 4. NOTE: K2 is in a socket for easy replacement.
4. If K2 checks out OK, the thermistor temperature sensor located on the optical bench near the front of the instrument could be at fault. Unplug the connector labeled "Bench", and measure the resistance of the thermistor. At room temperature it should have approximately 30K Ohms resistance near the 48°C set point it should have ~12K ohms.

8.4.1.3. GFC WHEEL TEMPERATURE

Like the bench heater above there are three possible causes for the GFC wheel temperature to have failed.

1. The wheel heater has failed. Check the resistance between pins 1 and 4 on the white five-pin connector just below the sample temperature sensor on the bench (pin 1 is the pointed end). It should be approximately 275 ohms.
2. Assuming that the I²C bus is working and that there is no other failure with the relay board, the solid-state relay (K1) on the relay board may have failed. Using the **WHEEL_HEATER** parameter under the signal I/O function, as described above, turn on and off K1 (D2 on the relay board should illuminate as the heater is turned on). Check the AC voltage present between Pin 1 and Pin 4.



WARNING:

HAZARDOUS VOLTAGES ARE PRESENT DURING THIS TEST

3. If the relay has failed there should be no change in the voltage across pins 1 and 4. NOTE: K1 is socketed for easy replacement.
4. If K1 checks out OK, the thermistor temperature sensor located at the front of the filter wheel assembly may have failed. Unplug the connector labeled "Wheel", and measure the resistance of the thermistor. The resistance near the 68°C set point is ~5.7k ohms.

8.4.1.4. IR PHOTO-DETECTOR TEC TEMPERATURE

If the **PHT DRIVE** test parameter described earlier in Table 8-2 is out of range there are two four possible causes of failure.

1. The screws retaining the IR photo detector to the absorption bench have become loose. Carefully tighten the screws, hand-tight and note whether, after the analyzer has come up to operating temperature, whether the **PHT DRIVE** voltage has returned to an acceptable level.

2. The two large transistor-type devices mounted to the side of the Absorption Bench have come loose from the bench. Tighten the retaining screws and note whether there is an improvement in the **PHT DRIVE** voltage.
3. The photo-detector has failed. Contact the factory for instructions.
4. The sync demodulator circuit board has failed. Contact the factory for instructions.

8.4.2. Excessive Noise

Noise is continuously monitored in the TEST functions as the **STABIL** reading and only becomes meaningful after sampling a constant gas concentration for at least 10 minutes. Compare the current **STABIL** reading with that recorded at the time of manufacture (included in the T360 *Final Test and Validation Data Sheet* shipped with the unit from Teledyne API).

1. The most common cause of excessive noise is leaks. Leak check and flow check the instrument described in Section 6.3.
2. Detector failure – caused by failure of the hermetic seal or over-temperature due to poor heat sinking of the detector ca To the optical bench. In addition to increased noise due to poor signal-to-noise ratio, another indicator of detector failure is a drop in the signal levels of the **CO₂ MEASURE** signal and **CO₂ REFERENCE** signal.
3. Sync/Demod Board failure. There are many delicate, high impedance parts on this board. Check the **CO₂ MEAS** and **CO₂ REF** Test Functions via the Front Panel Display.
4. The detector cooler control circuit can fail for reasons similar to the detector itself failing. Symptoms would be a change in **MR RATIO** Test Function when zero air is being sampled.

Also check the SIGNAL I/O parameter **PHT DRIVE**. After warm-up, and at 25°C ambient, if PHT DRIVE < 4800 mV, the cooler is working properly. If PHT DRIVE is > 4800 mV there is a malfunction.

5. The +5 and ±15 VDC voltages in the T360 are provided by switching power supplies. Switch mode supplies create DC outputs by switching the input AC waveform at high frequencies. As the components in the switcher age and degrade, the main problem observed is increased noise on the DC outputs. If a noisy switcher power supply is suspected, attach an oscilloscope to the DC output test points located on the top right hand edge of the Relay board. Look for short period spikes > 100 mV p-p on the DC output.

8.5. SUBSYSTEM CHECKOUT

The preceding sections of this manual discussed a variety of methods for identifying possible sources of failures or performance problems within the analyzer. In most cases this included a list of possible causes. This describes how to determine individually determine if a certain component or subsystem is actually the cause of the problem being investigated.

8.5.1. AC Mains Configuration

The analyzer is correctly configured for the AC mains voltage in use if:

1. The Sample Pump is running.
2. The GFC wheel motor is spinning. LED's D1 & D2 (located on the synch/demod PCA) should be flashing.
3. If incorrect power is suspected, check that the correct voltage and frequency is present at the line input on the rear panel.
 - If the unit is set for 230 VAC and is plugged into 115VAC, or 100VAC the sample pump will not start, and the heaters will not come up to temperature.
 - If the unit is set for 115 or 100 VAC and is plugged into a 230 VAC circuit, the circuit breaker built into the ON/OFF Switch on the Front Panel will trip to the OFF position immediately after power is switched on.

8.5.2. DC Power Supply

If you have determined that the analyzer's AC mains power is working, but the unit is still not operating properly, there may be a problem with one of the instrument's switching power supplies. The supplies can have two faults, namely no DC output, and noisy output.

To assist tracing DC Power Supply problems, the wiring used to connect the various printed circuit assemblies and DC Powered components and the associated test points on the relay board follow a standard color-coding scheme as defined in the following table:

Table 8-6: DC Power Test Point and Wiring Color Codes

NAME	TEST POINT#	TP AND WIRE COLOR
Dgnd	1	Black
+5V	2	Red
Agnd	3	Green
+15V	4	Blue
-15V	5	Yellow
+12R	6	Purple
+12V	7	Orange

A voltmeter should be used to verify that the DC voltages are correct per the values in the table below, and an oscilloscope, in AC mode, with band limiting turned on, can be used to evaluate if the supplies are producing excessive noise (> 100 mV p-p).

Table 8-7: DC Power Supply Acceptable Levels

POWER SUPPLY ASSY	VOLTAGE	CHECK RELAY BOARD TEST POINTS				MIN V	MAX V
		FROM TEST POINT		TO TEST POINT			
		NAME	#	NAME	#		
PS1	+5	Dgnd	1	+5	2	4.8	5.25
PS1	+15	Agnd	3	+15	4	13.5	16V
PS1	-15	Agnd	3	-15V	5	-14V	-16V
PS1	Agnd	Agnd	3	Dgnd	1	-0.05	0.05
PS1	Chassis	Dgnd	1	Chassis	N/A	-0.05	0.05
PS2	+12	+12V Ret	6	+12V	7	11.75	12.5
PS2	Dgnd	+12V Ret	6	Dgnd	1	-0.05	0.05

8.5.3. I²C Bus

Operation of the I²C bus can be verified by observing the behavior of D1 on the Relay PCA & D2 on the Valve Driver PCA . Assuming that the DC power supplies are operating properly, the I²C bus is operating properly if: D1 on the relay PCA and D2 of the Valve Driver PCA are flashing

- There is a problem with the I²C bus if both D1 on the relay PCA and D2 of the Valve Driver PCA are ON/OFF constantly (steady lit or steady off)

8.5.4. Touchscreen Interface

Verify the functioning of the touchscreen by observing the display when pressing a touchscreen control button. Assuming that there are no wiring problems and that the DC power supplies are operating properly, if pressing a control button on the display does not change the display, any of the following may be the problem:

- The touchscreen controller may be malfunctioning.
- The internal USB bus may be malfunctioning.

You can verify this failure by logging on to the instrument using APICOM or a terminal program to any of the communications ports. If the analyzer responds to remote commands and the display changes accordingly, the touchscreen interface may be faulty.

8.5.5. LCD Display Module

Verify the functioning of the front panel display by observing it when power is applied to the instrument. Assuming that there are no wiring problems and that the DC power supplies are operating properly, the display screen should light and show the splash screen with logo and other indications of its state as the CPU goes through its initialization process.

8.5.6. Relay Board

The relay board PCA (04135) can be most easily checked by observing the condition of the its status LEDs on the relay board, as described in Section 8.1.4.3, and the associated output when toggled on and off through signal I/O function in the diagnostic menu, see Section 8.1.3.

1. If the front panel display responds to button presses and D1 on the relay board is not flashing, then either the I²C connection between the motherboard and the relay board is bad, or the relay board itself is bad.
2. If D1 on the relay board is flashing and the status indicator for the output in question (heater power, valve drive, etc.) toggles properly using the signal I/O function, then the associated control device on the relay board is bad. Several of the control devices are in sockets and can be easily replaced. The table below lists the control device associated with a particular function:

Table 8-8: Relay Board Control Devices

FUNCTION	CONTROL DEVICE	IN SOCKET
Wheel Heater	K1	Yes
Bench Heater	K2	Yes
Spare AC Control	K3	Yes
IZS Valves	U4	Yes
IR Source Drive	U5	No

The IR source drive output can be verified by measuring the voltage at J16 with the IR source disconnected. It should be 11.5 ± 0.5 VDC.

8.5.7. Sensor Assembly

8.5.7.1. SYNC/DEMODULATOR ASSEMBLY

To verify that the Sync/Demodulator Assembly is working follow the procedure below:

1. Verify that D1 and D2 are flashing (they flash at different rates, see Table 8-3).
 - If not check the opto pickup assembly, Section 8.5.7.2 and the GFC wheel drive, Section 8.5.7.3.
 - If the wheel drive and opto pickup are working properly then verify that there is 2.4 ± 0.1 VAC and 2.5 ± 0.15 VDC between digital ground and TP 5 on the sync demod board. If not then check the wiring between the

sync/demod and opto pickup assembly (see interconnect drawing 04216). If good then the sync/demod board is bad.

2. Verify that the IR source is operating, Section 8.5.7.4.
3. With the analyzer connected to zero air, measure between TP11 (measure) and analog ground, and TP12 (reference) and analog ground.
 - If they are similar to values recorded on the factory data sheet then there is likely a problem with the wiring or the A/D converter.
 - If they are not then either the sync demodulator board or the IR-photodetector are bad. See Section 8.4.1.4 for problems with the IR-photodetector TEC drive.

8.5.7.2. OPTO PICKUP ASSEMBLY

Operation of the opto pickup PCA (04088) can be verified with a voltmeter. Measure the AC and DC voltage between digital ground on the relay board, or touchscreen and TP1 and TP2 on the sync pickup PCA. For a working board, with the GFC motor spinning, they should read 2.4 ±0.1 VAC and 2.5 ±0.15 VDC.

Further confirmation that the pickups and motor are operating properly can be obtained by measuring the frequency at TP1 and TP2 using a frequency counter, a digital volt meter with a frequency counter, or an oscilloscope per the table below.

Table 8-9: Opto Pickup Board Nominal Output Frequencies

AC MAINS FREQ.	NOMINAL MEASURED FREQUENCY	
	TP1	TP2
50 Hz	25	300
60 Hz	30	360

8.5.7.3. GFC WHEEL DRIVE

If the D1 and D2 on the sync demodulator board are not flashing then:

1. Check for power to the motor by measuring between pins 1 and 3 on the connector feeding the motor. For instruments configured for 120 or 220-240VAC there should be approximately 88 VAC for instruments configured for 100VAC, it should be the voltage of the AC mains, approximately 100VAC.
2. Verify that the frequency select jumper, JP4, is properly set on the Relay Board. For 50 Hz operation it should be installed. For 60 Hz operation may either be missing or installed in a vertical orientation.
3. If there is power to the motor and the frequency select jumper is properly set then the motor is likely bad. See Section 8.6.2 for instructions on removing and replacing the GFC assembly that the motor is bolted to.

8.5.7.4. IR SOURCE

The IR source can be checked using the following procedure:

1. Disconnect the source and check its resistance when cold. When new, the source should have a cold resistance of more than 1.5 Ohms but less than 3.5 Ohms. If not, then the source is bad.
2. With the source disconnected, energize the analyzer and wait for it to start operating. Measure the drive Voltage between pins 1 and 2 on the jack that the source is normally connected to; it should be 11.5 ± 0.25 VDC. If not, then there is a problem with either the wiring, the Relay Board, or the +12V power supply.
3. If the drive voltage is correct in step 2, then remove the source from the heat sink assembly (2 screws on top) and connect to its mating connector. Observe the light being emitted from the source. It should be centered at the bottom of the U-shaped element. If there is either no emission or a badly centered emission then the source is bad.

8.5.7.5. PRESSURE/FLOW SENSOR ASSEMBLY

The pressure/flow sensor PCA, located on the top of the absorption bench, can be checked with a Voltmeter using the following procedure which, assumes that the wiring is intact, and that the motherboard and the power supplies are operating properly.

- For Pressure related problems:
 - Measure the voltage across C1 it should be 5 ± 0.25 VDC. If not then the board is bad.
 - Measure the voltage across TP4 and TP1. With the sample pump disabled it should be 4500 mV \pm 250 mV. With the pump energized it should be approximately 200 mV less. If not, then S1, the pressure transducer is bad, the board is bad, or there is a pneumatic failure preventing the pressure transducer from sensing the absorption cell pressure properly.
- For flow related problems:
 - Measure the voltage across TP2 and TP1 it should be 10 ± 0.25 VDC. If not then the board is bad.
 - Measure the voltage across TP3 and TP1. With proper flow (800 cc/min at the sample inlet) this should be approximately 4.5V (this voltage will vary with altitude). With flow stopped (sample inlet blocked) the voltage should be approximately 1V. If the voltage is incorrect, the flow sensor is bad, the board is bad or there is a leak upstream of the sensor.

8.5.8. Motherboard

8.5.8.1. A/D FUNCTIONS

The simplest method to check the operation of the A-to-D converter on the motherboard is to use the Signal I/O function under the DIAG menu to check the two A/D reference voltages and input signals that can be easily measured with a voltmeter.

1. Use the Signal I/O function (see Section 8.1.3 and Appendix A) to view the value of **REF_4096_MV** and **REF_GND**. If both are within 3 mV of nominal (4096 and 0), and are stable, ± 0.5 mV then the basic A/D is functioning properly. If not then the motherboard is bad.
2. Choose a parameter in the Signal I/O function such as **SAMPLE_PRESSURE**, **SAMPLE_FLOW**, **CO₂_MEASURE** or **CO₂_REFERENCE**. Compare these voltages at their origin (see interconnect drawing 04215 and interconnect list 04216) with the voltage displayed through the signal I/O function. If the wiring is intact but there is a large difference between the measured and displayed voltage (± 10 mV) then the motherboard is bad.

8.5.8.2. ANALOG OUTPUTS: VOLTAGE

To verify that the analog outputs are working properly, connect a voltmeter to the output in question and perform an analog output step test as described in Section 4.13.4.

For each of the steps, taking into account any offset that may have been programmed into channel (see Section 4.13.3), the output should be within 1% of the nominal value listed in the table below except for the 0% step, which should be within 2 to 3 mV. If one or more of the steps fails to be within this range then it is likely that there has been a failure of the either or both of the DACs and their associated circuitry on the motherboard.

Table 8-10: Analog Output Test Function - Nominal Values Voltage Outputs

		FULL SCALE OUTPUT VOLTAGE			
		100MV	1V	5V	10V
STEP	%	NOMINAL OUTPUT VOLTAGE			
1	0	0	0	0	0
2	20	20 mV	0.2	1	2
3	40	40 mV	0.4	2	4
4	60	60 mV	0.6	3	6
5	80	80 mV	0.8	4	8
6	100	100 mV	1.0	5	10

8.5.8.3. ANALOG OUTPUTS: CURRENT LOOP

To verify that the analog outputs with the optional current mode output are working properly, connect a 250 ohm resistor across the outputs and use a voltmeter to measure the output as described in Section 4.13.4.4 and then perform an analog output step test as described in Section 4.13.3.

For each step the output should be within 1% of the nominal value listed in the table below.

Table 8-11: Analog Output Test Function - Nominal Values Current Outputs

		OUTPUT RANGE			
		2 -20		4 -20	
		NOMINAL OUTPUT VALUES			
STEP	%	CURRENT	V(250 OHMS)	CURRENT	V(250 OHMS)
1	0	2 mA	0.5V	4	1
2	20	5.6	1.4	7.2	1.8
3	40	9.2	2.3	10.4	2.6
4	60	12.8	3.2	13.6	3.4
5	80	16.4	4.1	16.8	4.2
6	100	20	5	20	5

8.5.8.4. STATUS OUTPUTS

The procedure below can be used to test the Status outputs (Figure 4-13):

1. Connect a jumper between the “D” pin and the “▽” pin on the status output connector.
2. Connect a 1000 ohm resistor between the “+” pin and the pin for the status output that is being tested.
3. Connect a voltmeter between the “▽” pin and the pin of the output being tested (see table below).

Under the **DIAG** → **SIGNAL I/O** menu (see Section 8.1.3), scroll through the inputs and outputs until you get to the output in question. Alternately turn on and off the output noting the voltage on the voltmeter, it should vary between 0 volts for ON and 5 volts for OFF.

Table 8-12: Status Outputs Check

PIN (LEFT TO RIGHT)	STATUS
1	SYSTEM OK
2	CONC VALID
3	HIGH RANGE
4	ZERO CAL
5	SPAN CAL
6	DIAG MODE
7	ALRM1
8	ALRM2

8.5.8.5. CONTROL INPUTS – REMOTE ZERO, SPAN

The control input bits can be tested by the following procedure:

1. Connect a jumper from the +5 pin on the Status connector to the x5V on the Control In connector.
2. Connect a second jumper from the '-' pin on the Status connector to the A pin on the Control In connector. The instrument should switch from **SAMPLE** mode to **ZERO CAL R** mode.
3. Connect a second jumper from the '-' pin on the Status connector to the B pin on the Control In connector. The instrument should switch from **SAMPLE** mode to **SPAN CAL R** mode.
4. In each case, the T360 should return to SAMPLE mode when the jumper is removed.

8.5.9. CPU

There are two major types of failures associated with the CPU board: complete failure and a failure associated with the Disk on Module (DOM). If either of these failures occur, contact the factory.

For complete failures, assuming that the power supplies are operating properly and the wiring is intact, the CPU is faulty if on power-on, the watchdog LED on the motherboard is not flashing.

In some rare circumstances, this failure may be caused by a bad IC on the motherboard, specifically U57, the large, 44-pin device on the lower right hand side of the board. If this is true, removing U57 from its socket will allow the instrument to start up but the measurements will be invalid.

If the analyzer stops during initialization (the front panel display shows a fault or warning message), it is likely that the DOM, the firmware or the configuration and data files have been corrupted.

8.5.10. RS-232 Communications

8.5.10.1. GENERAL RS-232 TROUBLESHOOTING

Teledyne API analyzers use the RS-232 communications protocol to allow the instrument to be connected to a variety of computer-based equipment. RS-232 has been used for many years and as equipment has become more advanced, connections between various types of hardware have become increasingly difficult. Generally, every manufacturer observes the signal and timing requirements of the protocol very carefully.

Problems with RS-232 connections usually center around one of the following areas:

1. Incorrect cabling and connectors. See Section 4.11.2 for connector and pin-out information.
2. The BAUD rate and protocol are incorrectly configured. See Section 4.11.10.
3. If a modem is being used, additional configuration and wiring rules must be observed. See Section 8.5.10.2.
4. Incorrect setting of the DTE – DCE Switch is set correctly. See Section 4.11.4.
5. Cable (03596) that connects the serial COM ports of the CPU to J12 of the motherboard (Figure 4-8) may not be properly seated.

8.5.10.2. TROUBLESHOOTING ANALYZER/MODEM OR TERMINAL OPERATION

These are the general steps for troubleshooting problems with a modem connected to a Teledyne API analyzer.

1. Check cables for proper connection to the modem, terminal or computer.
2. Check to make sure the DTE-DCE is in the correct position as described in Section 4.11.4.
3. Check to make sure the set up command is correct (See Section 4.15.2.6)
4. Verify that the Ready to Send (RTS) signal is at logic high. The T360 sets pin 7 (RTS) to greater than 3 volts to enable modem transmission.
5. Make sure the BAUD rate, word length, and stop bit settings between modem and analyzer match, see Section 4.11.10.
6. Use the RS-232 test function to send “w” characters to the modem, terminal or computer; see Section 4.11.11.
7. Get your terminal, modem or computer to transmit data to the analyzer (holding down the space bar is one way); the green LED should flicker as the instrument is receiving data.
8. Make sure that the communications software or terminal emulation software is functioning properly.

Further help with serial communications is available in a separate manual “RS-232 Programming Notes” Teledyne API part number 013500000.

8.6. REPAIR PROCEDURES

This contains procedures that might need to be performed on rare occasions when a major component of the analyzer requires repair or replacement.

8.6.1. Repairing Sample Flow Control Assembly

The critical flow orifice is housed in the flow control assembly (Teledyne API part number: 001760400) located on the top of the optical bench. A sintered filter protects the jewel orifice so it is unusual for the orifice to need replacing, but if it does, or the filter needs replacement please use the following procedure (see the Spare Parts list in Appendix B for part numbers and kits):

1. Turn off power to the analyzer.
2. Locate the assembly attached to the sample pump, see Figure 3-5.
3. Disconnect the pneumatic connection from the flow assembly and the assembly from the pump.
4. Remove the fitting and the components as shown in the exploded view in Figure 8-10.
5. Replace the o-rings (p/n OR000001) and the sintered filter (p/n FL000001).
6. If replacing the critical flow orifice itself (P/N 00094100), make sure that the side with the colored window (usually red) is facing upstream to the flow gas flow.
7. Apply new Teflon[®] tape to the male connector threads
8. Re-assemble in reverse order.
9. After reconnecting the power and pneumatic lines, flow check the instrument as described in Section 6.3.3.

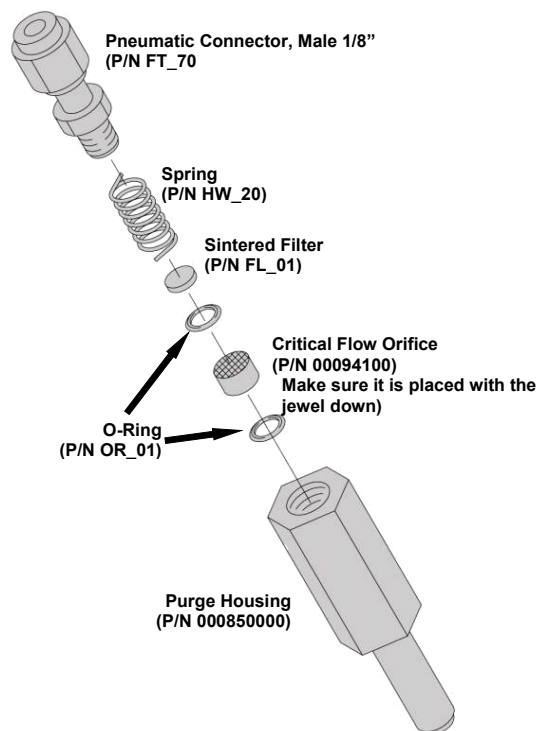

Figure 8-10: Critical Flow Restrictor Assembly Disassembly

8.6.2. Removing/Replacing the GFC Wheel

When removing or replacing the GFC Wheel it is important to perform the disassembly in the following order to avoid damaging the components:

1. Turn off the analyzer.
2. Remove the top cover as described in "Getting Started" Section 3.1.
3. Open the instrument's hinged front panel.
4. Locate the GFC wheel/motor assembly (see Figure 3-5).
5. Unplug the following electronic components:
 - The GFC wheel housing temperature sensor;
 - GFC wheel heater
 - GFC wheel motor power supply
 - IR source
6. Unscrew the purge gas line hex nut and remove the 1/8 inch FEP purge gas line.

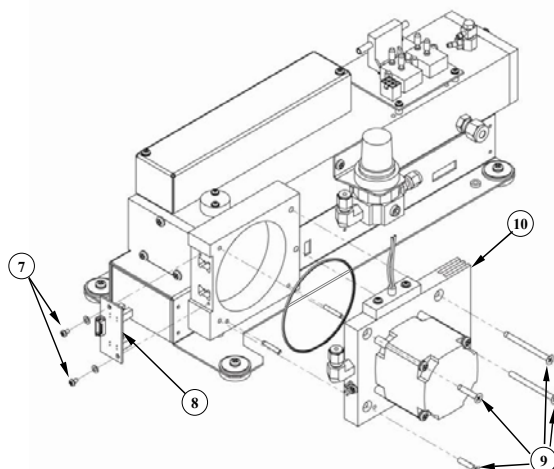

Figure 8-11: Opening the GFC Wheel Housing

7. Remove the two (2) screws holding the opto-pickup printed circuit assembly to the GFC wheel housing.
8. Carefully remove the opto-pickup printed circuit assembly.
9. Remove the four (4) screws holding the GFC wheel motor/heat sink assembly to the GFC wheel housing.
10. Carefully remove the GFC wheel motor/heat sink assembly from the GFC wheel housing.
11. Remove the one (1) screw fastening the GFC wheel/mask assembly to the GFC motor hub.

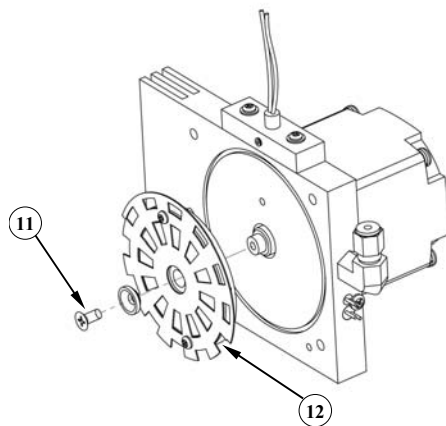

Figure 8-12: Removing the GFC Wheel

12. Remove the GFC wheel/mask assembly.
13. Follow the previous steps in reverse order to put the GFC wheel/motor assembly back together.

8.6.3. Disk-On-Module Replacement Procedure

NOTE

Servicing of circuit components requires electrostatic discharge protection, i.e. ESD grounding straps, mats and containers. Failure to use ESD protection when working with electronic assemblies will void the instrument warranty. Refer to Section 9 for more information on preventing ESD damage.

Replacing the Disk-on-Module (DOM) will cause loss of all DAS data; it may also cause loss of some instrument configuration parameters unless the replacement DOM carries the exact same firmware version. Whenever changing the version of installed software, the memory must be reset. Failure to ensure that memory is reset can cause the analyzer to malfunction, and invalidate measurements.

After the memory is reset, the A/D converter must be re-calibrated, and all information collected in Step 1 below must be re-entered before the instrument will function correctly. Also, zero and span calibration should be performed.

1. Document all analyzer parameters that may have been changed, such as range, auto-cal, analog output, serial port and other settings before replacing the DOM.
2. Turn off power to the instrument, fold down the rear panel by loosening the mounting screws.
3. When looking at the electronic circuits from the back of the analyzer, locate the Disk-on-Module in the right-most socket of the CPU board.
4. The DOM should carry a label with firmware revision, date and initials of the programmer.
5. Remove the nylon standoff clip that mounts the DOM over the CPU board, and lift the DOM off the CPU. Do not bend the connector pins.
6. Install the new Disk-on-Module, making sure the notch at the end of the chip matches the notch in the socket.
7. It may be necessary to straighten the pins somewhat to fit them into the socket. Press the chip all the way in.
8. Close the rear panel and turn on power to the machine.
9. If the replacement DOM carries a firmware revision, re-enter all of the setup information.

8.7. FREQUENTLY ASKED QUESTIONS

The following is a list from the Teledyne API's Technical Support Department of the most commonly asked questions relating to the Model CO₂ Analyzer.

Question	Answer
<p>Why does the instrument not appear on the LAN or Internet?</p>	<p>Most problems related to Internet communications via the Ethernet card will be due to problems external to the instrument (e.g. bad network wiring or connections, failed routers, malfunctioning servers, etc.) However, there are several symptoms that indicate the problem may be with the Ethernet card itself. If neither of the Ethernet cable's two status LED's (located on the back of the cable connector) is lit while the instrument is connected to a network:</p> <ul style="list-style-type: none"> • Verify that the instrument is being connected to an active network jack. • Check the internal cable connection between the Ethernet card and the CPU board.
<p>How do I get the instrument to zero / Why is the zero button not displayed?</p>	<p>See Section 8.3.4 Inability to zero.</p>
<p>How do I get the instrument to span / Why is the span button not displayed?</p>	<p>See Section 8.3.3 Inability to span.</p>
<p>Why does the ENTR button sometimes disappear on the Front Panel Display?</p>	<p>During certain types of adjustments or configuration operations, the ENTR button will disappear if you select a setting that is nonsensical (such as trying to set the 24-hour clock to 25:00:00) or out of the allowable range for that parameter (such as selecting a DAS Holdoff period of more than 20 minutes). Once you adjust the setting in question to an allowable value, the ENTR button will re-appear.</p>
<p>Is there an optional midpoint calibration?</p>	<p>There is an optional mid point linearity adjustment; however, midpoint adjustment is applicable only to applications where CO₂ measurements are expected above 100 ppm. Call Teledyne Instrument's Technical Support Department for more information on this topic.</p>
<p>How do I make the display and data logger analog input agree?</p>	<p>This most commonly occurs when an independent metering device is used besides the data logger/recorded to determine gas concentration levels while calibrating the analyzer. These disagreements result from the analyzer, the metering device and the data logger having slightly different ground levels. Both the electronic scale and offset of the analog outputs can be adjusted (see Section 4.13.4.3). Alternatively, use the data logger itself as the metering device during calibrations procedures.</p>
<p>How do I perform a leak check?</p>	<p>See Section 6.3.3.</p>
<p>How do I measure the sample flow</p>	<p>Sample flow is measured by attaching a calibrated rotameter, wet test meter, or other flow-measuring device to the sample inlet port when the instrument is operating. The sample flow should be 800 cm³/min ±10%. See Section 6.3.4.</p>

Question	Answer
How long does the IR source last?	Typical lifetime is about 2-3 years.
Where is the sintered filter/sample flow control orifice?	These components are located inside the flow control assembly that is attached to the inlet side of the sample pump, see Figure 3-5. See Section 8.6.1 for instructions on disassembly and replacement.
How do I set up a SEQUENCE to run a nightly calibration check?	The setup of this option is located in Section 5.6.
How do I set the analog output signal range and offset?	Instructions for this can be found in Section 4.13.4 which describes analog I/O configuration.
What is the averaging time for a T360?	The default averaging time, optimized for ambient pollution monitoring, is 150 seconds for stable concentrations and 10 seconds for rapidly changing concentrations; see Section 7.6.1 for more information. However, it is adjustable over a range of 0.5 second to 200 seconds (please contact Technical Support for more information).

9. A PRIMER ON ELECTRO-STATIC DISCHARGE

Teledyne Instruments considers the prevention of damage caused by the discharge of static electricity to be extremely important part of making sure that your analyzer continues to provide reliable service for a long time. This section describes how static electricity occurs, why it is so dangerous to electronic components and assemblies as well as how to prevent that damage from occurring.

9.1. HOW STATIC CHARGES ARE CREATED

Modern electronic devices such as the types used in the various electronic assemblies of your analyzer, are very small, require very little power and operate very quickly. Unfortunately, the same characteristics that allow them to do these things also make them very susceptible to damage from the discharge of static electricity. Controlling electrostatic discharge begins with understanding how electro-static charges occur in the first place.

Static electricity is the result of something called triboelectric charging which happens whenever the atoms of the surface layers of two materials rub against each other. As the atoms of the two surfaces move together and separate, some electrons from one surface are retained by the other.

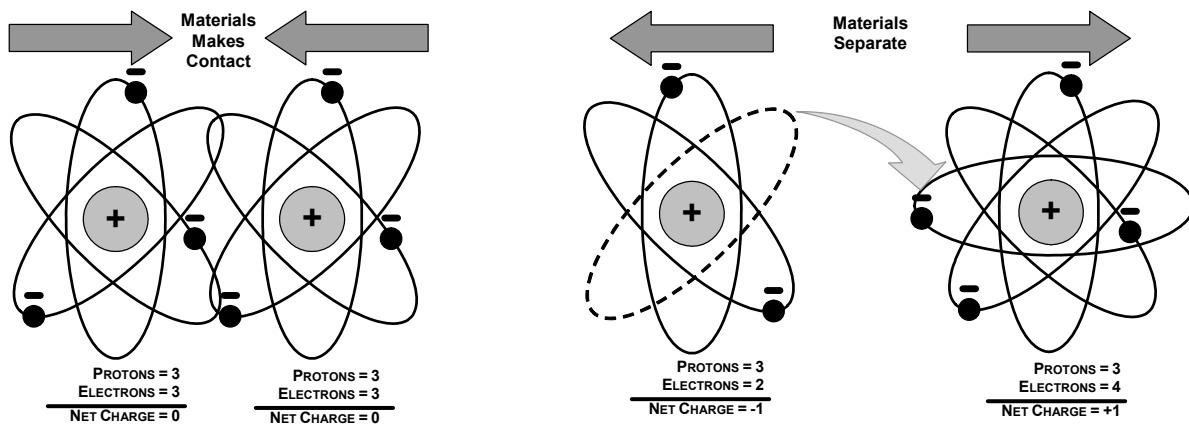

Figure 9-1: Triboelectric Charging

If one of the surfaces is a poor conductor or even a good conductor that is not grounded, the resulting positive or negative charge cannot bleed off and becomes trapped in place, or static. The most common example of triboelectric charging happens when someone wearing leather or rubber soled shoes walks across a nylon carpet or linoleum tiled floor. With each step, electrons change places and the resulting electro-static charge builds up, quickly reaching significant levels. Pushing an epoxy printed circuit board across a workbench, using a plastic handled screwdriver or even the constant jostling of Styrofoam™ pellets during shipment can also build hefty static charges

Table 9-1: Static Generation Voltages for Typical Activities

MEANS OF GENERATION	65-90% RH	10-25% RH
Walking across nylon carpet	1,500V	35,000V
Walking across vinyl tile	250V	12,000V
Worker at bench	100V	6,000V
Poly bag picked up from bench	1,200V	20,000V
Moving around in a chair padded with urethane foam	1,500V	18,000V

9.2. HOW ELECTRO-STATIC CHARGES CAUSE DAMAGE

Damage to components occurs when these static charges come into contact with an electronic device. Current flows as the charge moves along the conductive circuitry of the device and the typically very high voltage levels of the charge overheat the delicate traces of the integrated circuits, melting them or even vaporizing parts of them. When examined by microscope the damage caused by electro-static discharge looks a lot like tiny bomb craters littered across the landscape of the component's circuitry.

A quick comparison of the values in Table 9-1 with the those shown in the Table 9-2, listing device susceptibility levels, shows why *Semiconductor Reliability News* estimates that approximately 60% of device failures are the result of damage due to electro-static discharge.

Table 9-2: Sensitivity of Electronic Devices to Damage by ESD

DEVICE	DAMAGE SUSCEPTIBILITY VOLTAGE RANGE	
	DAMAGE BEGINS OCCURRING AT	CATASTROPHIC DAMAGE AT
MOSFET	10	100
VMOS	30	1800
NMOS	60	100
GaAsFET	60	2000
EPROM	100	100
JFET	140	7000
SAW	150	500
Op-AMP	190	2500
CMOS	200	3000
Schottky Diodes	300	2500
Film Resistors	300	3000
This Film Resistors	300	7000
ECL	500	500
SCR	500	1000
Schottky TTL	500	2500

Potentially damaging electro-static discharges can occur:

- Any time a charged surface (including the human body) discharges to a device. Even simple contact of a finger to the leads of a sensitive device or assembly can allow enough discharge to cause damage. A similar discharge can occur from a charged conductive object, such as a metallic tool or fixture.
- When static charges accumulated on a sensitive device discharges from the device to another surface such as packaging materials, work surfaces, machine surfaces or other device. In some cases, charged device discharges can be the most destructive.

A typical example of this is the simple act of installing an electronic assembly into the connector or wiring harness of the equipment in which it is to function. If the assembly is carrying a static charge, as it is connected to ground a discharge will occur.

- Whenever a sensitive device is moved into the field of an existing electro-static field, a charge may be induced on the device in effect discharging the field onto the device. If the device is then momentarily grounded while within the electrostatic field or removed from the region of the electrostatic field and grounded somewhere else, a second discharge will occur as the charge is transferred from the device to ground.

9.3. COMMON MYTHS ABOUT ESD DAMAGE

- **I didn't feel a shock so there was no electro-static discharge:** The human nervous system isn't able to feel a static discharge of less than 3500 volts. Most devices are damaged by discharge levels much lower than that.
- **I didn't touch it so there was no electro-static discharge:** Electro-static charges are fields whose lines of force can extend several inches or sometimes even feet away from the surface bearing the charge.
- **It still works so there was no damage:** Sometimes the damage caused by electro-static discharge can completely sever a circuit trace causing the device to fail immediately. More likely, the trace will be only partially occluded by the damage causing degraded performance of the device or worse, weakening the trace. This weakened circuit may seem to function fine for a short time, but even the very low voltage and current levels of the device's normal operating levels will eat away at the defect over time causing the device to fail well before its designed lifetime is reached.

These latent failures are often the most costly since the failure of the equipment in which the damaged device is installed causes down time, lost data, lost productivity, as well as possible failure and damage to other pieces of equipment or property.

- **Static Charges can't build up on a conductive surface:** There are two errors in this statement.

Conductive devices can build static charges if they are not grounded. The charge will be equalized across the entire device, but without access to earth ground, they are still trapped and can still build to high enough levels to cause damage when they are discharged.

A charge can be induced onto the conductive surface and/or discharge triggered in the presence of a charged field such as a large static charge clinging to the surface of a nylon jacket of someone walking up to a workbench.

- **As long as my analyzer is properly installed, it is safe from damage caused by static discharges:** It is true that when properly installed the chassis ground of your analyzer is tied to earth ground and its electronic components are prevented from building static electric charges themselves. This does not prevent discharges from static fields built up on other things, like you and your clothing, from discharging through the instrument and damaging it.

9.4. BASIC PRINCIPLES OF STATIC CONTROL

It is impossible to stop the creation of instantaneous static electric charges. It is not, however difficult to prevent those charges from building to dangerous levels or prevent damage due to electro-static discharge from occurring.

9.4.1. General Rules

Only handle or work on all electronic assemblies at a properly set up ESD station. Setting up an ESD safe workstation need not be complicated. A protective mat properly tied to ground and a wrist strap are all that is needed to create a basic anti-ESD workstation (see Figure 9-2).

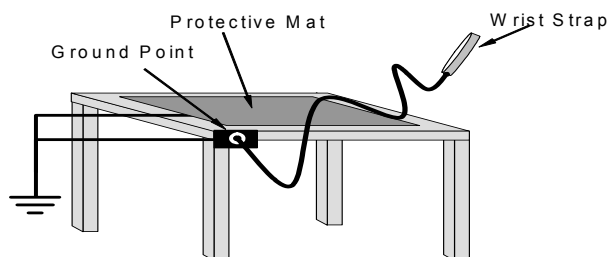

Figure 9-2: Basic anti-ESD Work Station

For technicians that work in the field, special lightweight and portable anti-ESD kits are available from most suppliers of ESD protection gear. These include everything needed to create a temporary anti-ESD work area anywhere.

- **Always wear an Anti-ESD wrist strap when working on the electronic assemblies of your analyzer.** An anti-ESD wrist strap keeps the person wearing it at or near the same potential as other grounded objects in the work area and allows static charges to dissipate before they can build to dangerous levels. Anti-ESD wrist straps terminated with alligator clips are available for use in work areas where there is no available grounded plug.

Also, anti-ESD wrist straps include a current limiting resistor (usually around one meg-ohm) that protects you should you accidentally short yourself to the instrument's power supply.

- **Simply touching a grounded piece of metal is insufficient.** While this may temporarily bleed off static charges present at the time, once you stop touching the grounded metal new static charges will immediately begin to re-

build. In some conditions, a charge large enough to damage a component can rebuild in just a few seconds.

- **Always store sensitive components and assemblies in anti-ESD storage bags or bins:** Even when you are not working on them, store all devices and assemblies in a closed anti-Static bag or bin. This will prevent induced charges from building up on the device or assembly and nearby static fields from discharging through it.
- **Use metallic anti-ESD bags for storing and shipping ESD sensitive components and assemblies rather than pink-poly bags.** The famous, “pink-poly” bags are made of a plastic that is impregnated with a liquid (similar to liquid laundry detergent) which very slowly sweats onto the surface of the plastic creating a slightly conductive layer over the surface of the bag.

While this layer may equalizes any charges that occur across the whole bag, it does not prevent the build up of static charges. If laying on a conductive, grounded surface, these bags will allow charges to bleed away but the very charges that build up on the surface of the bag itself can be transferred through the bag by induction onto the circuits of your ESD sensitive device. Also, the liquid impregnating the plastic is eventually used up after which the bag is as useless for preventing damage from ESD as any ordinary plastic bag.

Anti-Static bags made of plastic impregnated with metal (usually silvery in color) provide all of the charge equalizing abilities of the pink-poly bags but also, when properly sealed, create a Faraday cage that completely isolates the contents from discharges and the inductive transfer of static charges.

Storage bins made of plastic impregnated with carbon (usually black in color) are also excellent at dissipating static charges and isolating their contents from field effects and discharges.

- **Never use ordinary plastic adhesive tape near an ESD sensitive device or to close an anti-ESD bag.** The act of pulling a piece of standard plastic adhesive tape, such as Scotch[®] tape, from its roll will generate a static charge of several thousand or even tens of thousands of volts on the tape itself and an associated field effect that can discharge through or be induced upon items up to a foot away.

9.4.2. Basic anti-ESD Procedures for Analyzer Repair and Maintenance

9.4.2.1. WORKING AT THE INSTRUMENT RACK

When working on the analyzer while it is in the instrument rack and plugged into a properly grounded power supply.

1. Attach your anti-ESD wrist strap to ground before doing anything else.
 - Use a wrist strap terminated with an alligator clip and attach it to a bare metal portion of the instrument chassis. This will safely connect you to the same ground level to which the instrument and all of its components are connected.
2. Pause for a second or two to allow any static charges to bleed away.
3. Open the casing of the analyzer and begin work. Up to this point, the closed metal casing of your analyzer has isolated the components and assemblies inside from any conducted or induced static charges.
4. If you must remove a component from the instrument, do not lay it down on a non-ESD preventative surface where static charges may lie in wait.
5. Only disconnect your wrist strap after you have finished work and closed the case of the analyzer.

9.4.2.2. WORKING AT AN ANTI-ESD WORK BENCH.

When working on an instrument of an electronic assembly while it is resting on an anti-ESD work bench:

1. Plug your anti-ESD wrist strap into the grounded receptacle of the work station before touching any items on the work station and while standing at least a foot or so away. This will allow any charges you are carrying to bleed away through the ground connection of the workstation and prevent discharges due to field effects and induction from occurring.
2. Pause for a second or two to allow any static charges to bleed away.
3. Only open any anti-ESD storage bins or bags containing sensitive devices or assemblies after you have plugged your wrist strap into the workstation.
 - Lay the bag or bin on the workbench surface.
 - Before opening the container, wait several seconds for any static charges on the outside surface of the container to be bled away by the workstation's grounded protective mat.
4. Do not pick up tools that may be carrying static charges while also touching or holding an ESD Sensitive Device.
 - Only lay tools or ESD-sensitive devices and assemblies on the conductive surface of your workstation. Never lay them down on any non-ESD preventative surface.

5. Place any static sensitive devices or assemblies in anti-static storage bags or bins and close the bag or bin before unplugging your wrist strap.
6. Disconnecting your wrist strap is always the last action taken before leaving the workbench.

9.4.2.3. TRANSFERRING COMPONENTS FROM RACK TO BENCH AND BACK

When transferring a sensitive device from an installed Teledyne Instruments analyzer to an Anti-ESD workbench or back:

1. Follow the instructions listed above for working at the instrument rack and workstation.
2. Never carry the component or assembly without placing it in an anti-ESD bag or bin.
3. Before using the bag or container allow any surface charges on it to dissipate:
 - If you are at the instrument rack, hold the bag in one hand while your wrist strap is connected to a ground point.
 - If you are at an anti-ESD workbench, lay the container down on the conductive work surface.
 - In either case wait several seconds.
4. Place the item in the container.
5. Seal the container. If using a bag, fold the end over and fastening it with anti-ESD tape.
 - Folding the open end over isolates the component(s) inside from the effects of static fields.
 - Leaving the bag open or simply stapling it shut without folding it closed prevents the bag from forming a complete protective envelope around the device.
6. Once you have arrived at your destination, allow any surface charges that may have built up on the bag or bin during travel to dissipate:
 - Connect your wrist strap to ground.
 - If you are at the instrument rack, hold the bag in one hand while your wrist strap is connected to a ground point.
 - If you are at a anti-ESD work bench, lay the container down on the conductive work surface
 - In either case wait several seconds
7. Open the container.

9.4.2.4. OPENING SHIPMENTS FROM TELEDYNE INSTRUMENTS

Packing materials such as bubble pack and Styrofoam pellets are extremely efficient generators of static electric charges. To prevent damage from ESD, Teledyne Instruments ships all electronic components and assemblies in properly sealed anti-ESD containers.

Static charges will build up on the outer surface of the anti-ESD container during shipping as the packing materials vibrate and rub against each other. To prevent these static charges from damaging the components or assemblies being shipped make sure that you always unpack shipments from Teledyne Instruments by:

1. Opening the outer shipping box away from the anti-ESD work area.
2. Carry the still sealed anti-ESD bag, tube or bin to the anti-ESD work area.
3. Follow steps 6 and 7 of Section 9.4.2.3 above when opening the anti-ESD container at the work station.
4. Reserve the anti-ESD container or bag to use when packing electronic components or assemblies to be returned to Teledyne Instruments.

9.4.2.5. PACKING COMPONENTS FOR RETURN TO TELEDYNE INSTRUMENTS

Always pack electronic components and assemblies to be sent to Teledyne Instruments in anti-ESD bins, tubes or bags.



WARNING

- **DO NOT** use pink-poly bags.
- **NEVER** allow any standard plastic packaging materials to touch the electronic component/assembly directly
 - This includes, but is not limited to, plastic bubble-pack, Styrofoam peanuts, open cell foam, closed cell foam, and adhesive tape
- **DO NOT** use standard adhesive tape as a sealer. Use **ONLY** anti-ESD tape

1. Never carry the component or assembly without placing it in an anti-ESD bag or bin.
2. Before using the bag or container allow any surface charges on it to dissipate:
 - If you are at the instrument rack, hold the bag in one hand while your wrist strap is connected to a ground point.
 - If you are at an anti-ESD workbench, lay the container down on the conductive work surface.
 - In either case wait several seconds.
3. Place the item in the container.
4. Seal the container. If using a bag, fold the end over and fastening it with anti-ESD tape.

- Folding the open end over isolates the component(s) inside from the effects of static fields.
- Leaving the bag open or simply stapling it shut without folding it closed prevents the bag from forming a complete protective envelope around the device.

NOTE

If you do not already have an adequate supply of anti-ESD bags or containers available, Teledyne Instruments' Technical Support department will supply them. Follow the instructions listed above for working at the instrument rack and workstation.

:

This page intentionally left blank.

GLOSSARY

Note: Some terms in this glossary may not occur elsewhere in this manual.

Term	Description/Definition
10BaseT	an Ethernet standard that uses twisted ("T") pairs of copper wires to transmit at 10 megabits per second (Mbps)
100BaseT	same as 10BaseT except ten times faster (100 Mbps)
APICOM	name of a remote control program offered by Teledyne-API to its customers
ASSY	<i>Assembly</i>
CAS	<i>Code-Activated Switch</i>
CD	<i>Corona Discharge</i> , a frequently luminous discharge, at the surface of a conductor or between two conductors of the same transmission line, accompanied by ionization of the surrounding atmosphere and often by a power loss
CE	<i>Converter Efficiency</i> , the percentage of light energy that is actually converted into electricity
CEM	<i>Continuous Emission Monitoring</i>
Chemical formulas that may be included in this document:	
CO ₂	carbon dioxide
C ₃ H ₈	propane
CH ₄	methane
H ₂ O	water vapor
HC	general abbreviation for hydrocarbon
HNO ₃	nitric acid
H ₂ S	hydrogen sulfide
NO	nitric oxide
NO ₂	nitrogen dioxide
NO _x	nitrogen oxides, here defined as the sum of NO and NO ₂
NO _y	nitrogen oxides, often called odd nitrogen: the sum of NO _x plus other compounds such as HNO ₃ (definitions vary widely and may include nitrate (NO ₃), PAN, N ₂ O and other compounds as well)
NH ₃	ammonia
O ₂	molecular oxygen
O ₃	ozone
SO ₂	sulfur dioxide
cm ³	metric abbreviation for <i>cubic centimeter</i> (replaces the obsolete abbreviation "cc")
CPU	<i>Central Processing Unit</i>
DAC	<i>Digital-to-Analog Converter</i>
DAS	<i>Data Acquisition System</i>
DCE	<i>Data Communication Equipment</i>

Term	Description/Definition
DFU	<i>Dry Filter Unit</i>
DHCP	<i>Dynamic Host Configuration Protocol.</i> A protocol used by LAN or Internet servers to automatically set up the interface protocols between themselves and any other addressable device connected to the network
DIAG	<i>Diagnostics</i> , the diagnostic settings of the analyzer.
DOM	<i>Disk On Module</i> , a 44-pin IDE flash drive with up to 128MB storage capacity for instrument's firmware, configuration settings and data
DOS	<i>Disk Operating System</i>
DRAM	<i>Dynamic Random Access Memory</i>
DR-DOS	<i>Digital Research DOS</i>
DTE	<i>Data Terminal Equipment</i>
EEPROM	<i>Electrically Erasable Programmable Read-Only Memory</i> also referred to as a FLASH chip or drive
ESD	<i>Electro-Static Discharge</i>
ETEST	<i>Electrical Test</i>
Ethernet	a standardized (IEEE 802.3) computer networking technology for local area networks (LANs), facilitating communication and sharing resources
FEP	<i>Fluorinated Ethylene Propylene</i> polymer, one of the polymers that Du Pont markets as <i>Teflon</i> [®]
Flash	non-volatile, solid-state memory
FPI	<i>Fabry-Perot Interface</i> : a special light filter typically made of a transparent plate with two reflecting surfaces or two parallel, highly reflective mirrors
GFC	<i>Gas Filter Correlation</i>
I ² C bus	a clocked, bi-directional, serial bus for communication between individual analyzer components
IC	<i>Integrated Circuit</i> , a modern, semi-conductor circuit that can contain many basic components such as resistors, transistors, capacitors etc in a miniaturized package used in electronic assemblies
IP	<i>Internet Protocol</i>
IZS	<i>Internal Zero Span</i>
LAN	<i>Local Area Network</i>
LCD	<i>Liquid Crystal Display</i>
LED	<i>Light Emitting Diode</i>
LPM	<i>Liters Per Minute</i>
MFC	<i>Mass Flow Controller</i>
M/R	<i>Measure/Reference</i>

Term	Description/Definition
MOLAR MASS	the mass, expressed in grams, of 1 mole of a specific substance. Conversely, one mole is the amount of the substance needed for the molar mass to be the same number in grams as the atomic mass of that substance. EXAMPLE: The atomic weight of Carbon is 12 therefore the molar mass of Carbon is 12 grams. Conversely, one mole of carbon equals the amount of carbon atoms that weighs 12 grams. Atomic weights can be found on any Periodic Table of Elements.
NDIR	<i>Non-Dispersive Infrared</i>
NIST-SRM	<i>National Institute of Standards and Technology - Standard Reference Material</i>
PC	<i>Personal Computer</i>
PCA	<i>Printed Circuit Assembly, the PCB with electronic components, ready to use</i>
PC/AT	<i>Personal Computer / Advanced Technology</i>
PCB	<i>Printed Circuit Board, the bare board without electronic component</i>
PFA	<i>Per-Fluoro-Alkoxy, an inert polymer; one of the polymers that Du Pont markets as Teflon[®]</i>
PLC	<i>Programmable Logic Controller, a device that is used to control instruments based on a logic level signal coming from the analyzer</i>
PLD	<i>Programmable Logic Device</i>
PLL	<i>Phase Lock Loop</i>
PMT	<i>Photo Multiplier Tube, a vacuum tube of electrodes that multiply electrons collected and charged to create a detectable current signal</i>
P/N (or PN)	<i>Part Number</i>
PSD	<i>Prevention of Significant Deterioration</i>
PTFE	<i>Poly-Tetra-Fluoro-Ethylene, a very inert polymer material used to handle gases that may react on other surfaces; one of the polymers that Du Pont markets as Teflon[®]</i>
PVC	<i>Poly Vinyl Chloride, a polymer used for downstream tubing</i>
Rdg	Reading
RS-232	specification and standard describing a serial communication method between DTE (Data Terminal Equipment) and DCE (Data Circuit-terminating Equipment) devices, using a maximum cable-length of 50 feet
RS-485	specification and standard describing a binary serial communication method among multiple devices at a data rate faster than RS-232 with a much longer distance between the host and the furthest device
SAROAD	<i>Storage and Retrieval of Aerometric Data</i>
SLAMS	<i>State and Local Air Monitoring Network Plan</i>
SLPM	<i>Standard Liters Per Minute of a gas at standard temperature and pressure</i>
STP	<i>Standard Temperature and Pressure</i>
TCP/IP	<i>Transfer Control Protocol / Internet Protocol, the standard communications protocol for Ethernet devices</i>
TEC	<i>Thermal Electric Cooler</i>
TPC	<i>Temperature/Pressure Compensation</i>

Term	Description/Definition
USB	<i>Universal Serial Bus</i> : a standard connection method to establish communication between peripheral devices and a host controller, such as a mouse and/or touchscreen and a personal computer or laptop
VARS	<i>Variables</i> , the variable settings of the instrument
V-F	<i>Voltage-to-Frequency</i>
Z/S	<i>Zero / Span</i>

APPENDIX A – Menu Trees and Software Documentation

APPENDIX A-1: Models T360/T360M and 360E/360EM Software Menu Trees

APPENDIX A-2: Setup Variables

APPENDIX A-3: Warnings and Test Measurements

APPENDIX A-4: Signal I/O Definitions

APPENDIX A-5: DAS Triggering Events

APPENDIX A-6: DAS Parameters

APPENDIX A-7: Terminal Command Designators

APPENDIX A-8: Terminal Key Assignments

APPENDIX A-9: MODBUS Register

This page intentionally left blank.

APPENDIX A-1: T360, 360E Software Menu Trees

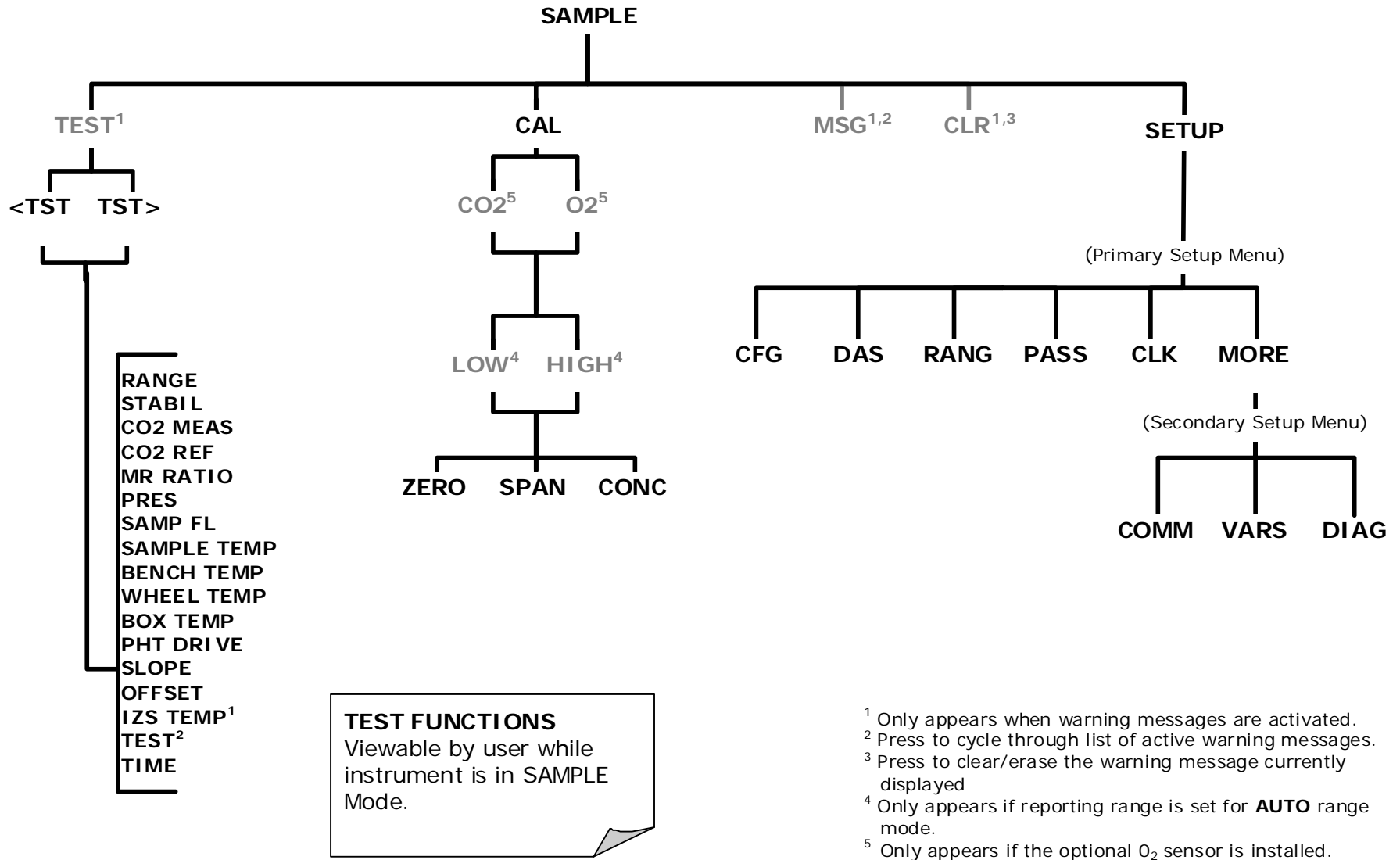

Figure A-1: Basic Sample Display Menu

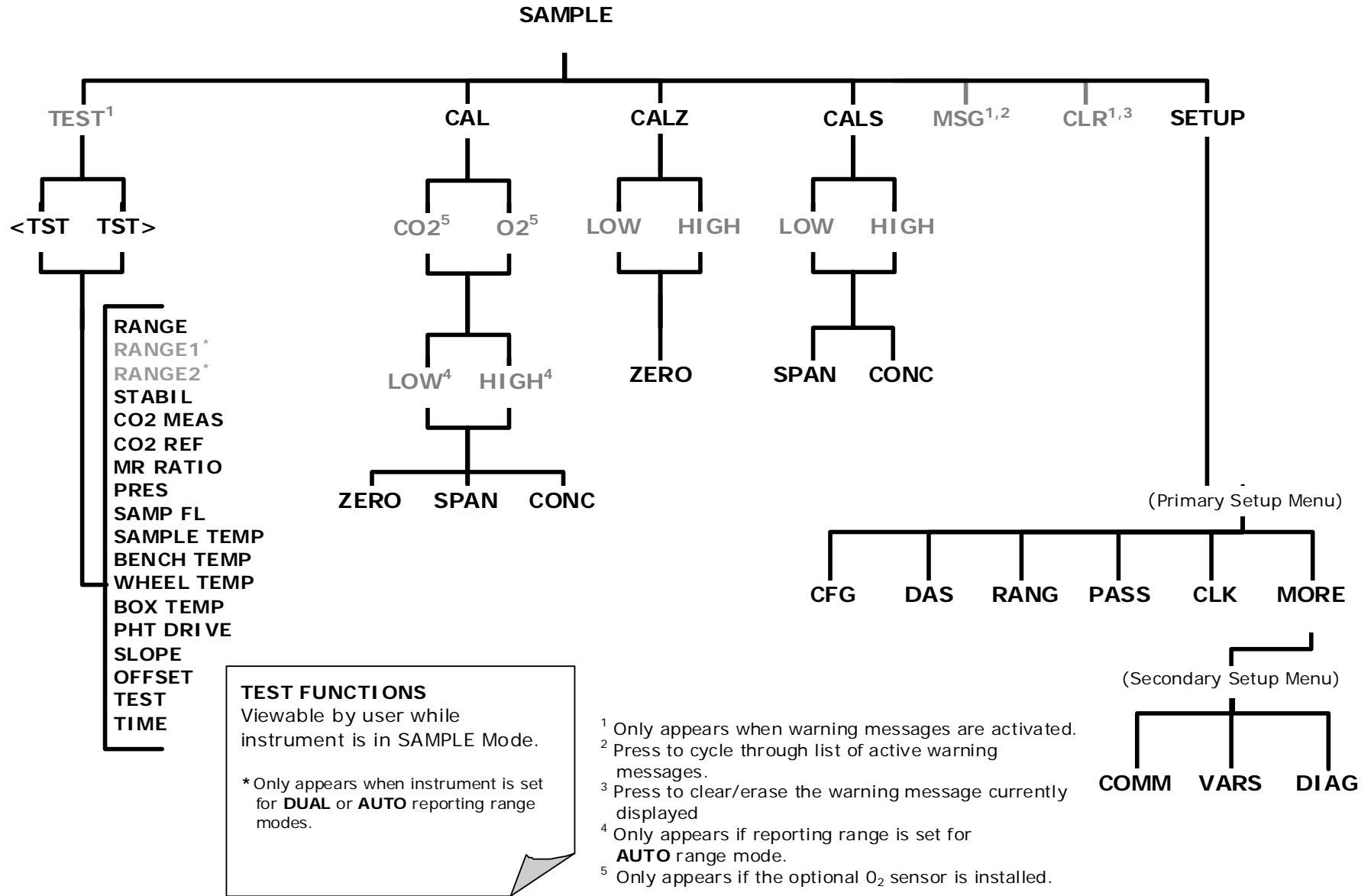

Figure A-2: Sample Display Menu - Units with Z/S Valve or IZS Option installed

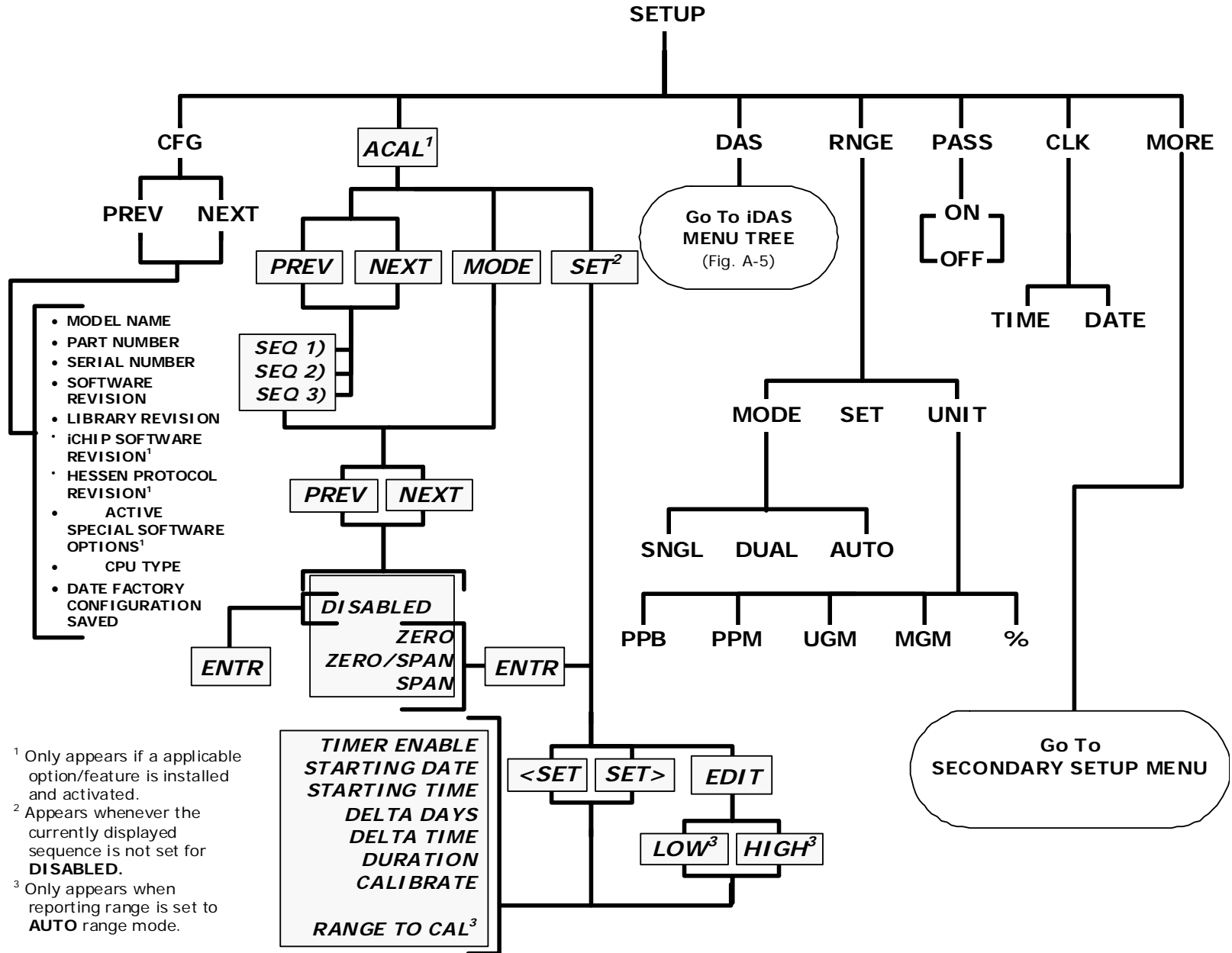

Figure A-3: Primary Setup Menu (Except DAS)

¹ Only appears if a applicable option/feature is installed and activated.

² Appears whenever the currently displayed sequence is not set for **DISABLED**.

³ Only appears when reporting range is set to **AUTO** range mode.

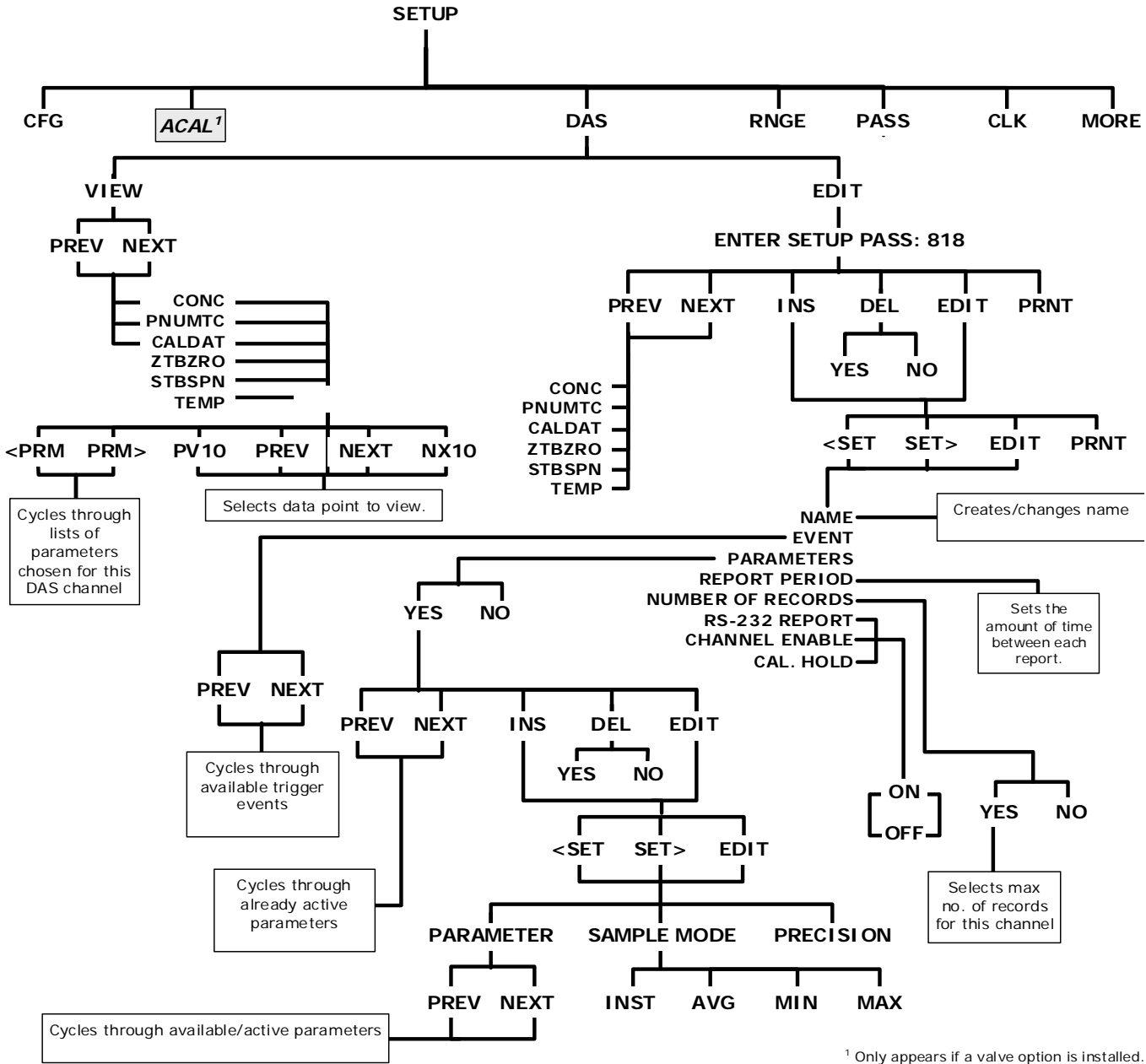
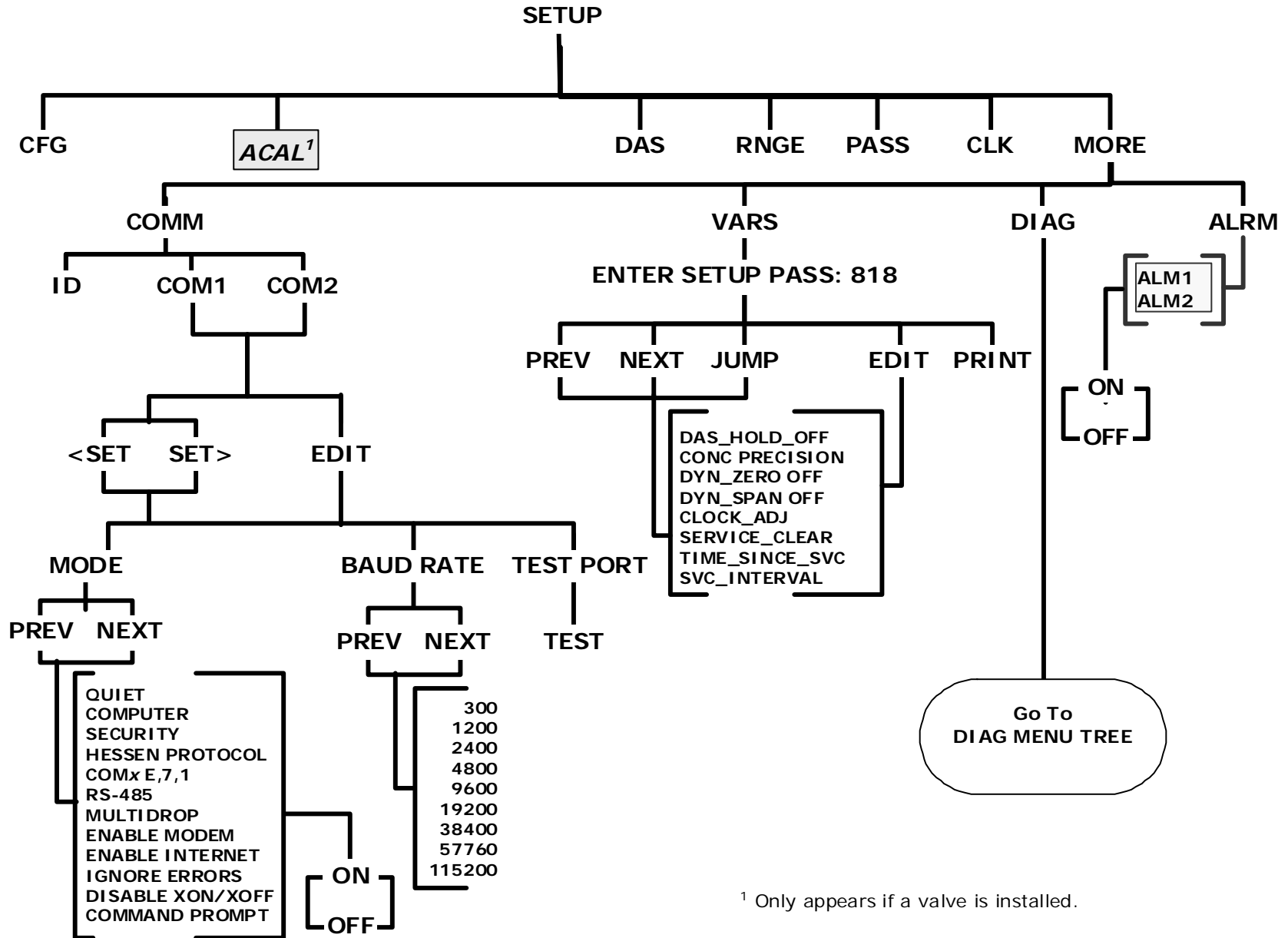
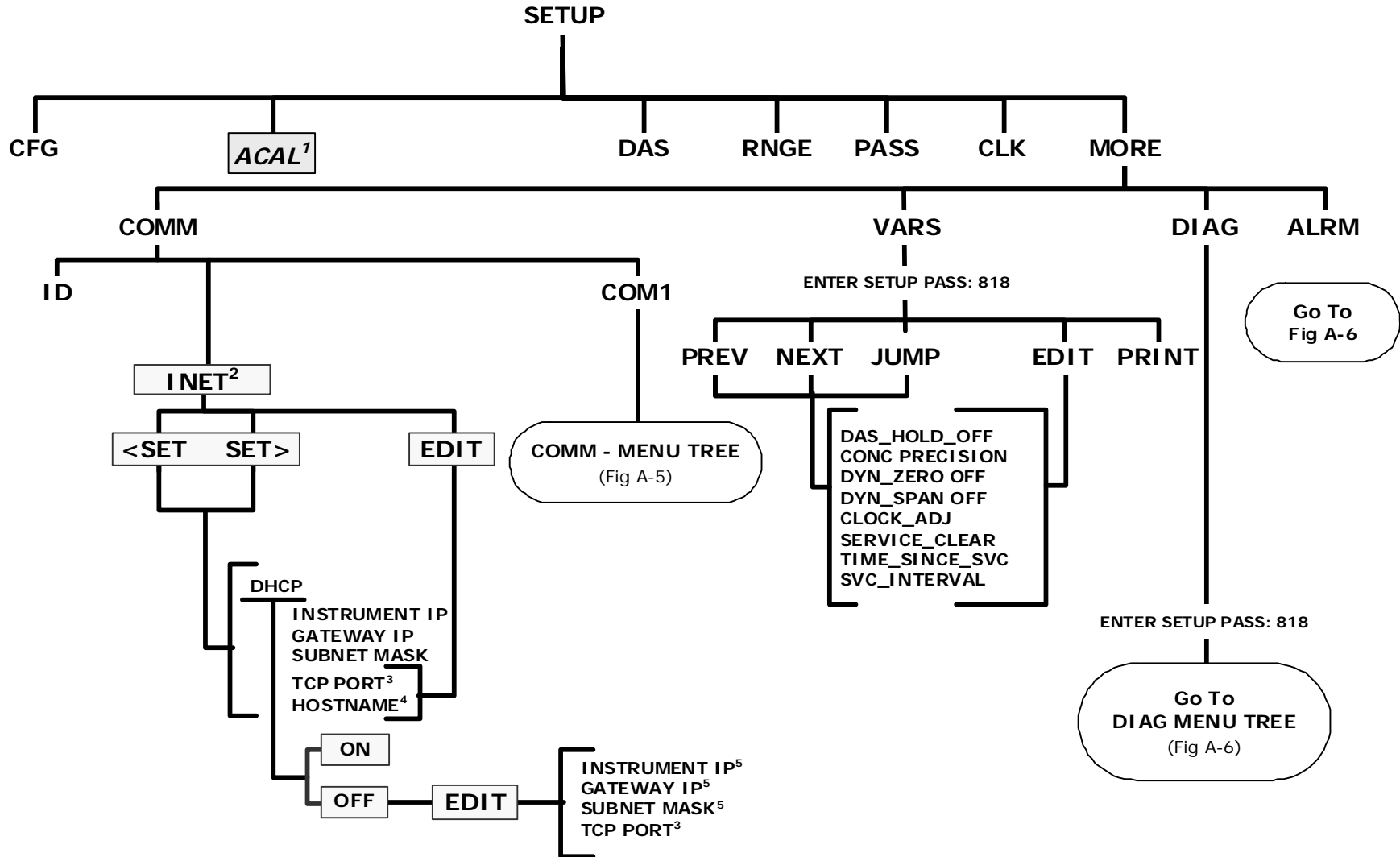

Figure A-4: Primary Setup Menu (DAS)



¹ Only appears if a valve is installed.

Figure A-5: Secondary Setup Menu (COMM, VARS & ALRM)



¹ Only appears if a valve option is installed.

² E-series only: Appears only when the Ethernet card option is installed.

³ Although **TCP PORT** is editable regardless of the **DHCP** state, do not change the setting for this property unless instructed to by Teledyne API Customer Service personnel.

⁴ **HOST NAME** is only editable when **DHCP** is **ON**.

⁵ **INSTRUMENT IP**, **GATEWAY IP** & **SUBNET MASK** are only editable when **DHCP** is **OFF**.

Figure A-6: Secondary Setup Menu (COMM Menu with Ethernet)

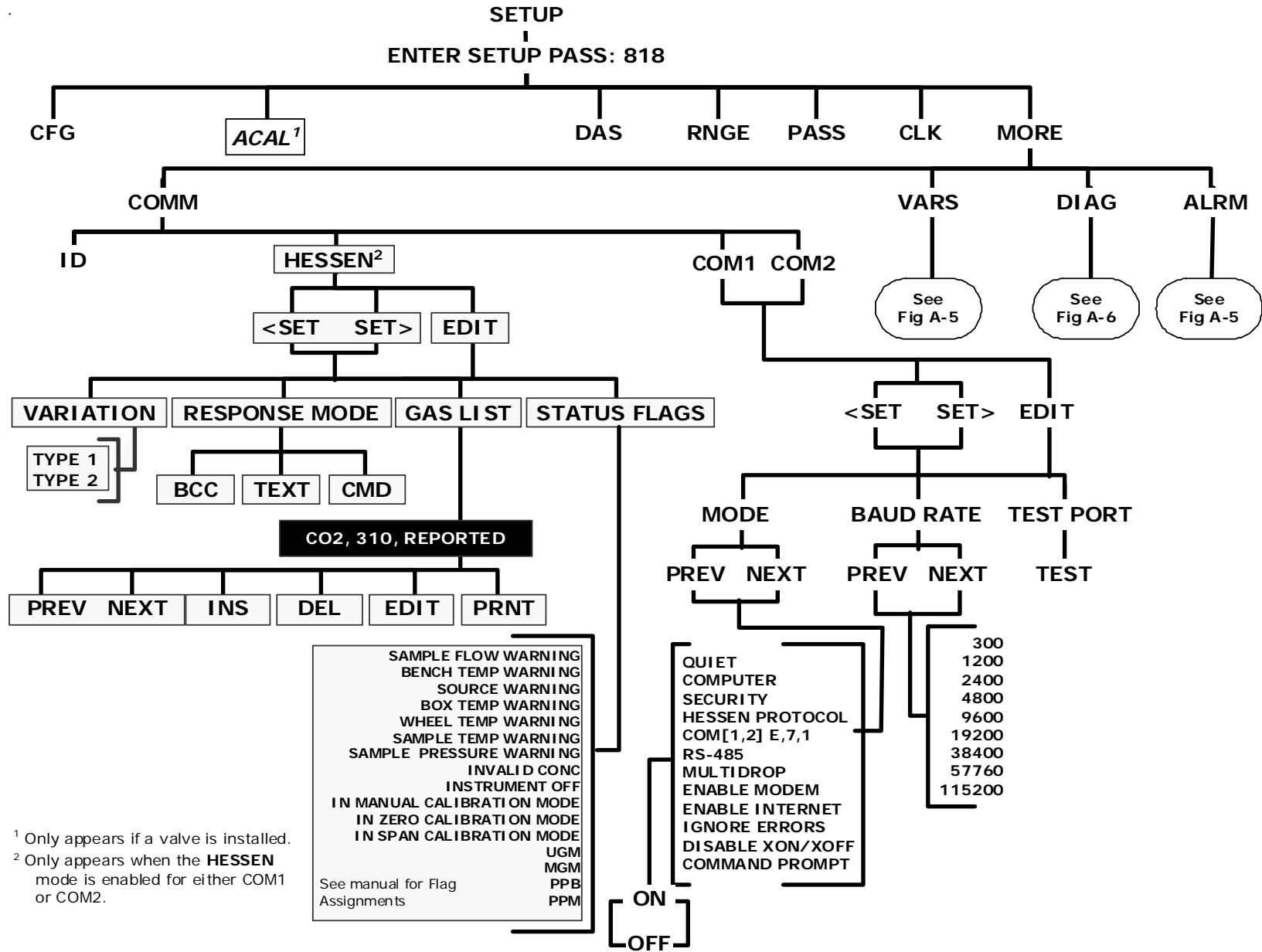

¹ Only appears if a valve is installed.

² Only appears when the **HESSEN** mode is enabled for either COM1 or COM2.

Figure A-7: Secondary Setup Menu (COMM Menu with HESSEN)

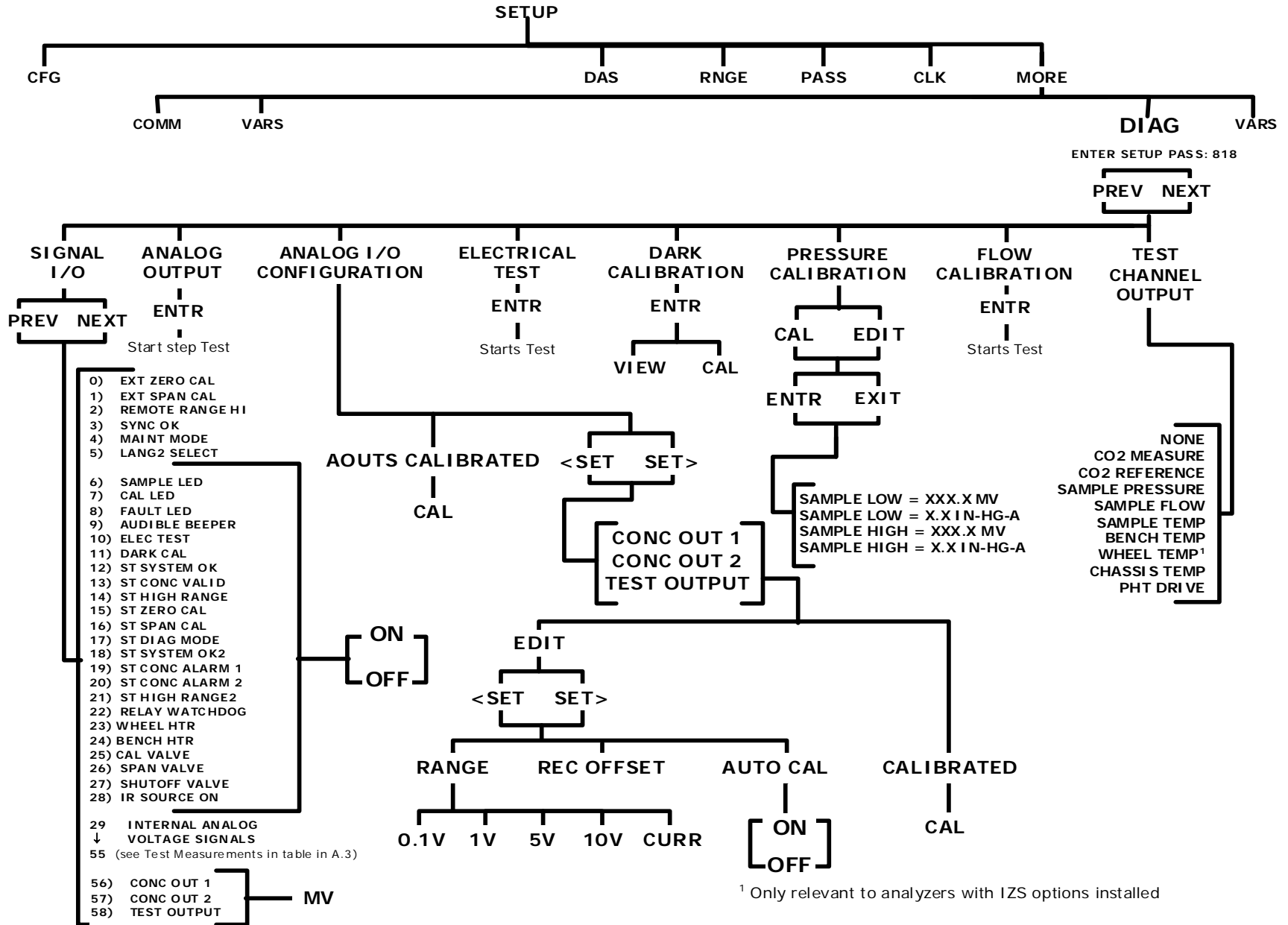

Figure A-8: Secondary Setup Menu (DIAG)

APPENDIX A-2: 300 Series Setup Variables For Serial I/O, Revision L.8

Setup Variable	Numeric Units	Default Value	Value Range	Description
Low Access Level Setup Variables (818 password)				
DAS_HOLD_OFF	Minutes	15	0.5–20	Duration of DAS hold off period.
CONC_PRECISION	—	3	AUTO, 0, 1, 2, 3, 4	Number of digits to display to the right of the decimal point for concentrations on the display.
REM_CAL_DURATION ¹⁷	Minutes	20	1–120	Duration of automatic calibration initiated from TAI protocol.
STABIL_GAS	—	CO ⁰	CO, CO ₂ ¹⁰ , O ₂ ¹⁴	Selects gas for stability measurement.
DYN_ZERO	—	OFF	ON, OFF	ON enables remote dynamic zero calibration; OFF disables it.
DYN_SPAN	—	OFF	ON, OFF	ON enables remote dynamic span calibration; OFF disables it.
CLOCK_ADJ	Sec./Day	0	-60–60	Time-of-day clock speed adjustment.
SERVICE_CLEAR	—	OFF	OFF ON	ON resets the service interval timer.
TIME_SINCE_SVC	Hours	0	0–500000	Time since last service.
SVC_INTERVAL	Hours	0	0–100000	Sets the interval between service reminders.
Medium Access Level Setup Variables (929 password)				
LANGUAGE_SELECT	—	ENGL ⁰	ENGL, SECD, EXTN	Selects the language to use for the user interface.
MAINT_TIMEOUT	Hours	2	0.1–100	Time until automatically switching out of software-controlled maintenance mode.
LATCH_WARNINGS	—	ON	ON, OFF	ON enables latching warning messages; OFF disables latching
DAYLIGHTSAVING_ENABLE	—	ON	ON, OFF	ON enables Daylight Saving Time change; OFF disables DST.
CONV_TIME	—	33 MS ⁰	33 MS, 66 MS, 133 MS, 266 MS, 533 MS, 1 SEC, 2 SEC	Conversion time for measure/reference detector channel.

Setup Variable	Numeric Units	Default Value	Value Range	Description
CO_DWELL	Seconds	0.2	0.1–30	Dwell time before taking measure or reference sample.
CO_SAMPLE	Samples	1	1–30	Number of samples to take in measure or reference mode.
PRE_FILT_SIZE ^{5, 19}	Samples	16	1–50	Moving average pre-filter size.
FILT_SIZE	Samples	750, 720 ^{9, 12} 200 ^{3, 8} 1000 ^{19, 23}	1–1000	Moving average filter size.
FILT_ASIZE	Samples	48, 20 ^{3, 8} , 40 ^{20, 22}	1–1000	Moving average filter size in adaptive mode.
FILT_DELTA	PPM	4, 0.7 ⁵ 15 ^{3, 8} 0.15 ^{9, 12} 0.4 ^{19, 23} 0.2 ^{20, 22}	1–1000	Absolute change to trigger adaptive filter.
FILT_PCT	%	10 5 ^{20, 22, 23}	1–100	Percent change to trigger adaptive filter.
FILT_DELAY	Seconds	90, 72 ^{20, 22}	0–180	Delay before leaving adaptive filter mode.
FILT_ADAPT	—	ON	ON, OFF	ON enables adaptive filter; OFF disables it.
CO2_DWELL ¹⁰	Seconds	0.1	0.1–30	Dwell time before taking each sample.
CO2_FILT_ADAPT ¹⁰	—	ON	ON, OFF	ON enables CO ₂ adaptive filter; OFF disables it.
CO2_FILT_SIZE ¹⁰	Samples	48	1–300	CO ₂ moving average filter size.
CO2_FILT_ASIZE ¹⁰	Samples	12	1–300	CO ₂ moving average filter size in adaptive mode.
CO2_FILT_DELTA ¹⁰	%	2	0.01–10	Absolute CO ₂ conc. change to trigger adaptive filter.
CO2_FILT_PCT ¹⁰	%	10	0.1–100	Percent CO ₂ conc. change to trigger adaptive filter.
CO2_FILT_DELAY ¹⁰	Seconds	90	0–300	Delay before leaving CO ₂ adaptive filter mode.
CO2_DIL_FACTOR ¹⁰	—	1	0.1–1000	Dilution factor for CO ₂ . Used only if is dilution enabled with <i>FACTORY_OPT</i> variable.
O2_DWELL ¹⁴	Seconds	1	0.1–30	Dwell time before taking each sample.
O2_FILT_ADAPT ¹⁴	—	ON	ON, OFF	ON enables O ₂ adaptive filter; OFF disables it.
O2_FILT_SIZE ¹⁴	Samples	60	1–500	O ₂ moving average filter size in normal mode.
O2_FILT_ASIZE ¹⁴	Samples	10	1–500	O ₂ moving average filter size in adaptive mode.

Setup Variable	Numeric Units	Default Value	Value Range	Description
O2_FILT_DELTA ¹⁴	%	2	0.1–100	Absolute change in O ₂ concentration to shorten filter.
O2_FILT_PCT ¹⁴	%	2	0.1–100	Relative change in O ₂ concentration to shorten filter.
O2_FILT_DELAY ¹⁴	Seconds	20	0–300	Delay before leaving O ₂ adaptive filter mode.
O2_DIL_FACTOR ¹⁴	—	1	0.1–1000	Dilution factor for O ₂ . Used only if is dilution enabled with <i>FACTORY_OPT</i> variable.
USER_UNITS	—	PPM ⁰	PPB, PPM, UGM, MGM % ^{4, 5, 9, 18}	Concentration units for user interface.
			PPM ^{3, 8} MGM ^{3, 8}	
NEG_CONC_SUPPRESS	—	OFF, ON ¹⁷	OFF, ON	ON pegs negative concentrations at zero; OFF permits negative concentrations
DIL_FACTOR	—	1	0.1–1000	Dilution factor. Used only if is dilution enabled with <i>FACTORY_OPT</i> variable.
DARK_CAL_DURATION	Seconds	180, 60 ⁴	10–600	Duration of dark cal. First two-thirds is stabilization period; final third is measure period.
DARK_MEAS_MV	mV	0	-1000–1000	Dark offset for measure reading.
DARK_REF_MV	mV	0	-1000–1000	Dark offset for reference reading.
CO2_COMP_ENABLE	—	OFF	ON, OFF	ON enables CO ₂ compensation; OFF disables it.
CO2_COMP_CONC	%	0	0–20	CO ₂ concentration to compensate for.
SOURCE_DRIFT_ENAB ²¹	—	OFF	ON, OFF	ON enables source drift compensation; OFF disables it.
SOURCE_DRIFT ²¹	PPB/Day	0	-500–500	Source drift compensation rate of change.
CO_CONST1	—	8000, 500 ^{15,20,22,23} 78.8 ^{9,12} 3020 ¹⁸ 500 ^{4,9,12} 39600 ⁸ 40000 ³	100–50000	CO calculation constant.

Setup Variable	Numeric Units	Default Value	Value Range	Description
CO_CONST2	—	0.2110 0.356 ^{20,22,23} 0.367 ¹⁵ 1.458 ^{9,12} 1.4625 ¹⁸ 1.448 ⁴ 0.192 ⁸ 0.187 ³ 0.1196 ²⁴	0–10	CO calculation constant.
ET_MEAS_GAIN	—	1	0.0001–9.9999	Electrical test gain factor for measure reading.
ET_REF_GAIN	—	1	0.0001–9.9999	Electrical test gain factor for reference reading.
ET_TARGET_DET	mV	4375	0–5000	Target detector reading during electrical test.
ET_TARGET_CONC	PPM	40, 400 ^{3,8}	1–9999.99	Target concentration during electrical test.
ET_CONC_RANGE	Conc.	50, 5000 ^{3,8}	0.1–50000	D/A concentration range during electrical test.
STD_TEMP	°K	321	1–500	Standard temperature for temperature compensation.
STD_PRESS	"Hg	28.5, 28.7 ⁸ , 28.8 ^{12,18} , 28.1 ⁴	1–50	Standard pressure for pressure compensation.
BENCH_SET	°C	48 Warnings: 43–53	0–100	Optical bench temperature set point and warning limits.
WHEEL_SET	°C	68, 62 ^{19,23} Warnings: 63–73, 57–67 ^{19,23}	0–100	Wheel temperature set point and warning limits.
O2_CELL_SET ¹⁴	°C	50 Warnings: 45–55	30–70	O ₂ sensor cell temperature set point and warning limits.
STD_O2_CELL_TEMP ¹⁴	°K	323	1–500	Standard O ₂ cell temperature for temperature compensation.
ZERO_APPLY_IN_CAL ⁵	—	ON	OFF, ON	ON applies auto-reference offset and dilution factor during zero/span calibration; OFF disables both. (Only applicable if ZERO_ENABLE is ON.)

Setup Variable	Numeric Units	Default Value	Value Range	Description
ZERO_DWELL ^{3,5,8}	Seconds, Minutes ⁵	7, 3 ⁵	1–60, 1–30 ⁵	Dwell time after closing or opening zero scrubber valve.
ZERO_SAMPLES ^{3,5,8}	Samples	15, 750 ⁵ , 1000 ¹⁹	1–1000	Number of zero samples to average.
ZERO_FILT_SIZE ^{3,5,8}	Samples	5, 1 ⁵	1–100	Auto-zero offset moving average filter size.
ZERO_LIMIT ^{3,5,8}	Ratio	1.2, 1.15 ^{3,8} , 1 ⁵	0–5	Minimum auto-zero ratio allowed; must be <i>greater</i> than this value to be valid.
ZERO_CAL ^{3,5,8}	Ratio	1.18	0.5–5	Calibrated auto-zero ratio.
CO_TARG_ZERO1	Conc.	0	-100.00– 999.99	Target CO concentration during zero offset calibration of range 1.
CO_TARG_MID1_1	Conc.	50 ⁵ , 300	0.01–9999.99	Target CO concentration during mid-point #1 calibration of range 1.
CO_TARG_MID2_1	Conc.	50 ⁵ , 300	0.01–9999.99	Target CO concentration during mid-point #2 calibration of range 1.
CO_SPAN1	Conc.	40, 400 ^{3,8}	0.01–9999.99	Target CO concentration during internal span calibration of range 1.
CO_SLOPE1	—	1	0.001–999.999	CO slope for range 1.
CO_OFFSET1	—	0	-10–10	CO offset for range 1.
CAL_BOX_TEMP1	°C	30	0–100	Calibrated box temperature for range 1.
CO_TARG_ZERO2	Conc.	0	-100.00– 999.99	Target CO concentration during zero offset calibration of range 2.
CO_TARG_MID1_2	Conc.	50 ⁵ , 300	0.01–9999.99	Target CO concentration during mid-point #1 calibration of range 2.
CO_TARG_MID2_2	Conc.	50 ⁵ , 300	0.01–9999.99	Target CO concentration during mid-point #2 calibration of range 2.
CO_SPAN2	Conc.	40, 400 ^{3,8}	0.01–9999.99	Target CO concentration during internal span calibration of range 2.
CO_SLOPE2	—	1	0.001–999.999	CO slope for range 2.
CO_OFFSET2	—	0	-10–10	CO offset for range 2.
CAL_BOX_TEMP2	°C	30	0–100	Calibrated box temperature for range 2.
CO2_TARG_MID1_CONC ¹⁰	%	6, 800 ¹⁶	0.1–1000, 0.1–2000 ¹⁶	Target CO ₂ concentration during mid-point #1 calibration.
CO2_TARG_MID2_CONC ¹⁰	%	6, 800 ¹⁶	0.1–1000, 0.1–2000 ¹⁶	Target CO ₂ concentration during mid-point #2 calibration.
CO2_TARG_SPAN_CONC ¹⁰	%	12	0.1–1000, 0.1–2000 ¹⁶	Target CO ₂ concentration during span calibration.

Setup Variable	Numeric Units	Default Value	Value Range	Description
CO2_SLOPE ¹⁰	—	1	0.5–5	CO ₂ slope.
CO2_OFFSET ¹⁰	%	0	-10–10, -100–100 ¹⁶	CO ₂ offset.
O2_TARG_SPAN_CONC ¹⁴	%	20.95	0.1–100	Target O ₂ concentration during span calibration.
O2_SLOPE ¹⁴	—	1	0.5–2	O ₂ slope.
O2_OFFSET ¹⁴	%	0	-10–10	O ₂ offset.
RANGE_MODE	—	SNGL ⁰	SNGL, DUAL, AUTO	Range control mode.
CONC_RANGE1	Conc.	50, 200 ⁶ , 500 ^{3,8}	0.1–50000	D/A concentration range 1.
CONC_RANGE2 ¹	Conc.	50, 200 ⁶ , 500 ^{3,8}	0.1–50000	D/A concentration range 2.
CO2_RANGE ¹⁰	%	15	0.1–500, 0.1–2000 ¹⁶	CO ₂ concentration range.
O2_RANGE ¹⁴	%	100	0.1–500	O ₂ concentration range.
RS232_MODE	BitFlag	0	0–65535	RS-232 COM1 mode flags. Add values to combine flags. 1 = quiet mode 2 = computer mode 4 = enable security 8 = enable hardware handshaking 16 = enable Hessen protocol ¹¹ 32 = enable multi-drop 64 = enable modem 128 = ignore RS-232 line errors 256 = disable XON / XOFF support 512 = disable hardware FIFOs 1024 = enable RS-485 mode 2048 = even parity, 7 data bits, 1 stop bit 4096 = enable command prompt 8192 = even parity, 8 data bits, 1 stop bit 16384 = enable dedicated MODBUS ASCII protocol 32678 = enable dedicated MODBUS RTU or TCP protocol 16384 = enable TAI protocol ¹⁷

Setup Variable	Numeric Units	Default Value	Value Range	Description
BAUD_RATE	—	115200 ⁰	300, 1200, 2400, 4800, 9600, 19200, 38400, 57600, 115200	RS-232 COM1 baud rate.
MODEM_INIT	—	"AT Y0 &D0 &H0 &I0 S0=2 &B0 &N6 &M0 E0 Q1 &W0" ⁰	Any character in the allowed character set. Up to 100 characters long.	RS-232 COM1 modem initialization string. Sent verbatim plus carriage return to modem on power up or manually.
RS232_MODE2	BitFlag	0	0–65535	RS-232 COM2 mode flags. <i>(Same settings as RS232_MODE.)</i>
BAUD_RATE2	—	19200 ⁰	300, 1200, 2400, 4800, 9600, 19200, 38400, 57600, 115200	RS-232 COM2 baud rate.
MODEM_INIT2	—	"AT Y0 &D0 &H0 &I0 S0=2 &B0 &N6 &M0 E0 Q1 &W0" ⁰	Any character in the allowed character set. Up to 100 characters long.	RS-232 COM2 modem initialization string. Sent verbatim plus carriage return to modem on power up or manually.
RS232_PASS	Password	940331	0–999999	RS-232 log on password.
MACHINE_ID	ID	300, 320 ⁴	0–9999	Unique ID number for instrument.
COMMAND_PROMPT	—	"Cmd> " ⁰	Any character in the allowed character set. Up to 100 characters long.	RS-232 interface command prompt. Displayed only if enabled with <i>RS232_MODE</i> variable.

Setup Variable	Numeric Units	Default Value	Value Range	Description
TEST_CHAN_ID	—	NONE ⁰	NONE, CO MEASURE, CO REFERENC E, VACUUM PRESSURE, SAMPLE PRESSURE, SAMPLE FLOW, SAMPLE TEMP, BENCH TEMP, WHEEL TEMP, O2 CELL TEMP ¹⁴ , CHASSIS TEMP, PHT DRIVE, TEMP4 ⁵	Diagnostic analog output ID.
REMOTE_CAL_MODE	—	LOW ⁰	LOW, HIGH, CO2 ¹⁰ , O2 ¹⁴	CO range or other gas to calibrate during contact closure or Hessen calibration.
PASS_ENABLE	—	OFF	ON, OFF	ON enables passwords; OFF disables them.
STABIL_FREQ	Seconds	10 120 ^{19, 23}	1–300	Stability measurement sampling frequency.
STABIL_SAMPLES	Samples	25	2–40	Number of samples in concentration stability reading.
PHOTO_TEMP_SET	mV	2500 Warnings: 250–4750	0–5000	Photometer temperature warning limits. Set point is not used.
SAMP_PRESS_SET	In-Hg	29.92 Warnings: 15–32	0–100	Sample pressure warning limits. Set point is not used.

Setup Variable	Numeric Units	Default Value	Value Range	Description
SAMP_FLOW_SET	cc/m	800, 2000 ¹³ 1800 ^{5,19}	0–5000	Sample flow warning limits. Set point is not used.
		Warnings: 640–960, 1400–2200 ^{5,19} 1500–2500 ¹³		
SAMP_FLOW_SLOPE	—	1 4.5 ^{5,19}	0.001–100	Slope term to correct sample flow rate.
VAC_SAMP_RATIO	—	0.53, 0.61 ¹³	0.1–2	Maximum vacuum pressure / sample pressure ratio for valid sample flow calculation.
PURGE_PRESS_SET	PSIG	7.5	0–100	Purge pressure warning limits. Set point is not used.
		Warnings: 2.5–12.5		
SAMP_TEMP_SET ²⁶	°C	30	0–100	Sample temperature warning limits. Set point is not used.
		Warnings: 10.1–100		
BOX_SET	°C	30	0–100	Internal box temperature warning limits. Set point is not used.
		Warnings: 5–48		
BOX2_SET ⁵ , OVEN_SET ^{19,23}	°C	30 46 ^{19,23}	0–100	Internal box temperature #2 / oven set point and warning limits.
		Warnings: 25–35 41–51 ^{19,23}		
BOX2_CYCLE ⁵ , OVEN_CYCLE ^{19,23}	Seconds	10	0.5–30	Internal box temperature #2/oven control cycle period.
BOX2_PROP ⁵ , OVEN_PROP ^{19,23}	1/°C	1 0.5 ^{19,23}	0–100	Internal box temperature #2/oven PID proportional coefficient. Proportional band is the reciprocal of this setting.
BOX2_INTEG ⁵ , OVEN_INTEG ^{19,23}	—	0.1 0.02 ^{19,23}	0–100	Internal box temperature #2/oven PID integral coefficient.
BOX2_DERIV ⁵ , OVEN_DERIV ^{19,23}	—	0	0–100	Internal box temperature #2/oven PID derivative coefficient.
BENCH_CYCLE	Seconds	2 15 ^{19,23}	0.5–30	Optical bench temperature control cycle period.
		Warnings: 1.5 ^{19,23}		
BENCH_PROP	1/°C	5 1.5 ^{19,23}	0–100	100V optical bench temperature PID proportional coefficient. Proportional band is the reciprocal of this setting.
BENCH_INTEG	—	0.5 1.5 ^{19,23}	0–100	100V optical bench temperature PID integral coefficient.

Setup Variable	Numeric Units	Default Value	Value Range	Description
BENCH_DERIV	—	2 0 ^{19,23}	0–100	100V optical bench temperature PID derivative coefficient.
BENCH_PROP2	1/°C	5 0.75 ^{19,23}	0–100	200V optical bench temperature PID proportional coefficient. Proportional band is the reciprocal of this setting.
BENCH_INTEG2	—	0.5 0.75 ^{19,23}	0–100	200V optical bench temperature PID integral coefficient.
BENCH_DERIV2	—	2 0 ^{19,23}	0–100	200V optical bench temperature PID derivative coefficient.
WHEEL_CYCLE	Seconds	4 2 ^{4,9,12,18} 8 ^{19,23}	0.5–30	Wheel temperature control cycle period.
WHEEL_PROP	1/°C	1 0.3 ^{19,23}	0–100	100V wheel temperature PID proportional coefficient. Proportional band is the reciprocal of this setting.
WHEEL_INTEG	—	0.135 0.035 ^{4,9,12,18} 0.06 ^{19,23}	0–100	100V wheel temperature PID integral coefficient.
WHEEL_DERIV	—	2 0 ^{19,23}	0–100	100V wheel temperature PID derivative coefficient.
WHEEL_PROP2	1/°C	1 0.1 ^{19,23}	0–100	200V wheel temperature PID proportional coefficient. Proportional band is the reciprocal of this setting.
WHEEL_INTEG2	—	0.135 0.035 ^{4,9,12,18} 0.01 ^{19,23}	0–100	200V wheel temperature PID integral coefficient.
WHEEL_DERIV2	—	2 0 ^{19,23}	0–100	200V wheel temperature PID derivative coefficient.
O2_CELL_CYCLE ¹⁴	Seconds	10	0.5–30	O ₂ cell temperature control cycle period.
O2_CELL_PROP ¹⁴	—	1	0–10	O ₂ cell PID temperature control proportional coefficient.
O2_CELL_INTEG ¹⁴	—	0.1	0–10	O ₂ cell PID temperature control integral coefficient.
O2_CELL_DERIV ¹⁴	—	0 (disabled)	0–10	O ₂ cell PID temperature control derivative coefficient.
BOX_TEMP_GAIN	PPB/DegC	0, 5 ⁹	0–100	Gain factor for box temperature compensation of concentration.
TPC_ENABLE	—	ON	OFF, ON	ON enables temperature/pressure compensation; OFF disables it.
CONC_LIN_ENABLE	—	ON	OFF, ON	ON enables concentration linearization; OFF disables it.
STAT_REP_PERIOD ¹⁷	Seconds	1	0.5–120	TAI protocol status message report period.

Setup Variable	Numeric Units	Default Value	Value Range	Description
SERIAL_NUMBER	—	"00000000" 0	Any character in the allowed character set. Up to 100 characters long.	Unique serial number for instrument.
DISP_INTENSITY	—	HIGH ⁰	HIGH, MED, LOW, DIM	Front panel display intensity.
I2C_RESET_ENABLE	—	ON	OFF, ON	ON enables automatic reset of the I ² C bus in the event of communication failures; OFF disables automatic reset.
CLOCK_FORMAT	—	"TIME=%H:%M:%S"	Any character in the allowed character set. Up to 100 characters long.	Time-of-day clock format flags. Enclose value in double quotes (") when setting from the RS-232 interface. "%a" = Abbreviated weekday name. "%b" = Abbreviated month name. "%d" = Day of month as decimal number (01 – 31). "%H" = Hour in 24-hour format (00 – 23). "%I" = Hour in 12-hour format (01 – 12). "%j" = Day of year as decimal number (001 – 366). "%m" = Month as decimal number (01 – 12). "%M" = Minute as decimal number (00 – 59). "%p" = A.M./P.M. indicator for 12-hour clock. "%S" = Second as decimal number (00 – 59). "%w" = Weekday as decimal number (0 – 6; Sunday is 0). "%y" = Year without century, as decimal number (00 – 99). "%Y" = Year with century, as decimal number. "%%" = Percent sign.
ALARM_TRIGGER ^{3,4}	Cycles	10	1–100	Concentration alarm trigger sensitivity adjustment.

Setup Variable	Numeric Units	Default Value	Value Range	Description
REF_SDEV_LIMIT	mV	50	0.1–500	Reference detector standard deviation must be below this limit to switch out of startup mode.
REF_SOURCE_LIMIT	mV	3000 (not used)	1–5000	Reference source warning limits. Set point is not used.
		Warnings: 1100–4800, 25–4800 ^{3, 4, 15}		
FACTORY_OPT	BitFlag	512, 768 ⁵	0–0x7ffffff	<p>Factory option flags. Add values to combine flags.</p> <p>1 = enable dilution factor</p> <p>2 = zero/span valves installed</p> <p>4 = enable conc. alarms</p> <p>8 = enable linearity adjustment factor</p> <p>16 = display units in concentration field</p> <p>32 = enable software-controlled maintenance mode</p> <p>64^{3, 5} = span valve installed</p> <p>128 = enable switch-controlled maintenance mode</p> <p>256 = compute only offset during zero calibration</p> <p>512 = 220 V A/C power</p> <p>1024 = non-zero offset calibration (linearity adjustment must also be enabled)</p> <p>2048 = enable Internet option⁷</p> <p>4096 = use “old” style numeric data entry menus when editing conc. table</p> <p>8192 = locate high range and zero cal. status outputs on relays</p> <p>16384 = enable external analog inputs²⁵</p>

Setup Variable	Numeric Units	Default Value	Value Range	Description
0				Enclose value in double quotes (") when setting from the RS-232 interface
1				Multi-range modes
2				Hessen protocol
3				T300H, 300EH
4				T360, 360E
5				T300U, 300EU
6				Fixed range special
7				E Series internet option.
8				T300M, 300EM
9				GFC7000E
10				CO ₂ option
11				Must power-cycle instrument for these options to take effect
12				T360U, 360EU
13				Riken Keiki special
14				O ₂ option
15				M320E
16				CO ₂ PPM sensor
17				TAI protocol
18				T360, 360EM
19				M300EU2
20				M320EU
21				Source drift compensation option
22				GFC7002EU
23				M320EU2
24				N ₂ O compensation option
25				T Series external analog input option.
26				Except M300EU2 and M320EU configurations.

APPENDIX A-3: 300 Series Warnings and Test Measurements, Revision L.8

Name ¹	Message Text	Description
Warnings		
WSYSRES	SYSTEM RESET	Instrument was power-cycled or the CPU was reset.
WDATAINIT	DATA INITIALIZED	Data storage was erased.
WCONFIGINIT	CONFIG INITIALIZED	Configuration storage was reset to factory configuration or erased.
WCONCALARM1	CONC ALARM 1 WARN	Concentration limit 1 exceeded.
WCONCALARM2	CONC ALARM 2 WARN	Concentration limit 2 exceeded.
WSOURCE	SOURCE WARNING	Reference reading minus dark offset outside of warning limits specified by <i>REF_SOURCE_LIMIT</i> variable.
WAUTOZERO ^{4,5}	AZERO WARN 1.001	Auto-reference ratio below limit specified by <i>ZERO_LIMIT</i> variable.
WBENCHTEMP	BENCH TEMP WARNING	Bench temperature outside of warning limits specified by <i>BENCH_SET</i> variable.
WWHEELTEMP	WHEEL TEMP WARNING	Wheel temperature outside of warning limits specified by <i>WHEEL_SET</i> variable.
WO2CELLTEMP ¹⁰	O2 CELL TEMP WARN	O ₂ sensor cell temperature outside of warning limits specified by <i>O2_CELL_SET</i> variable.
WSAMPFLOW ⁶	SAMPLE FLOW WARN	Sample flow outside of warning limits specified by <i>SAMP_FLOW_SET</i> variable.
WSAMPPRESS	SAMPLE PRESS WARN	Sample pressure outside of warning limits specified by <i>SAMP_PRESS_SET</i> variable.
WSAMPTEMP ¹³	SAMPLE TEMP WARN	Sample temperature outside of warning limits specified by <i>SAMP_TEMP_SET</i> variable.
WPURGEPRESS ⁹	PURGE PRESS WARN	Purge pressure outside of warning limits specified by <i>PURGE_PRESS_SET</i> variable.
WBOXTEMP	BOX TEMP WARNING	Internal box temperature outside of warning limits specified by <i>BOX_SET</i> variable.
WBOXTEMP2 ⁴	BOX TEMP2 WARNING	Internal box temperature #2 outside of warning limits specified by <i>BOX2_SET</i> variable.
WOVENTEMP ¹¹	OVEN TEMP WARNING	Oven temperature outside of warning limits specified by <i>OVEN_SET</i> variable.
WPHOTOTEMP	PHOTO TEMP WARNING	Photometer temperature outside of warning limits specified by <i>PHOTO_TEMP_SET</i> variable.
WDYNZERO	CANNOT DYN ZERO	Contact closure zero calibration failed while <i>DYN_ZERO</i> was set to <i>ON</i> .
WDYNSPAN	CANNOT DYN SPAN	Contact closure span calibration failed while <i>DYN_SPAN</i> was set to <i>ON</i> .

Name ¹	Message Text	Description
WREARBOARD	REAR BOARD NOT DET	Rear board was not detected during power up.
WRELAYBOARD	RELAY BOARD WARN	Firmware is unable to communicate with the relay board.
WFRONTPANEL	FRONT PANEL WARN	Firmware is unable to communicate with the front panel.
WANALOGCAL	ANALOG CAL WARNING	The A/D or at least one D/A channel has not been calibrated.
Test Measurements		
RANGE	RANGE=50.0 PPM ³ CO RANGE=50.0 PPM ^{3,7}	D/A range in single or auto-range modes.
RANGE1	RANGE1=50.0 PPM ³ CO RANGE1=50.0 PPM ^{3,7}	D/A #1 range in dual range mode.
RANGE2	RANGE2=50.0 PPM ³ CO RANGE2=50.0 PPM ^{3,7}	D/A #2 range in dual range mode.
CO2RANGE	CO2 RANGE=20 % ⁷	CO ₂ range.
O2RANGE	O2 RANGE=100 % ¹⁰	O ₂ range.
STABILITY	STABIL=0.0 PPM ³ CO STB=0.0 PPM ^{3,7,10} CO2 STB=0.0 % ⁷ O2 STB=0.0 % ¹⁰	Concentration stability (standard deviation based on setting of <i>STABIL_FREQ</i> and <i>STABIL_SAMPLES</i>).
RESPONSE ²	RSP=0.20(0.00) SEC	Instrument response. Length of each signal processing loop. Time in parenthesis is standard deviation.
COMEAS	CO MEAS=4125.0 MV	Detector measure reading.
COREF	CO REF=3750.0 MV	Detector reference reading.
MRRATIO	MR RATIO=1.100	Measure/reference ratio.
AUTOZERO ^{4,5}	AZERO RATIO=1.234	Measure/reference ratio during auto-reference.
SAMPPRESS	PRES=29.9 IN-HG-A	Sample pressure.
PURGEPRESS ⁹	PURGE=7.5 PSIG	Purge pressure
VACUUM ⁸	VAC=6.8 IN-HG-A	Vacuum pressure.
SAMPFLOW ⁶	SAMP FL=751 CC/M	Sample flow rate.
SAMPTEMP ¹³	SAMPLE TEMP=26.8 C	Sample temperature.
BENCHTEMP	BENCH TEMP=48.1 C	Bench temperature.
WHEELTEMP	WHEEL TEMP=68.1 C	Wheel temperature.
O2CELLTEMP ¹⁰	O2 CELL TEMP=50.2 C	O ₂ sensor cell temperature.
BOXTEMP	BOX TEMP=26.8 C	Internal box temperature.
BOXTEMP2 ⁴	BOX TEMP2=29.6 C	Internal box temperature #2.
OVENTEMP ¹¹	OVEN TEMP=30.1 C	Oven temperature
PHOTOTEMP	PHT DRIVE=2500.0 MV	Photometer temperature.

Name ¹	Message Text	Description
COSLOPE	SLOPE=1.000 CO SLOPE=1.000 ⁷	CO slope for current range, computed during zero/span calibration.
COSLOPE1	SLOPE1=1.000 CO SLOPE1=1.000 ⁷	CO slope for range #1 in dual range mode, computed during zero/span calibration.
COSLOPE2	SLOPE2=1.000 CO SLOPE2=1.000 ⁷	CO slope for range #2 in dual range mode, computed during zero/span calibration.
COOFFSET	OFFSET=0.000 CO OFFSET=0.000 ⁷	CO offset for current range, computed during zero/span calibration.
COOFFSET1	OFFSET1=0.000 CO OFFSET1=0.000 ⁷	CO offset for range #1 in dual range mode, computed during zero/span calibration.
COOFFSET2	OFFSET2=0.000 CO OFFSET2=0.000 ⁷	CO offset for range #2 in dual range mode, computed during zero/span calibration.
CO2SLOPE ⁷	CO2 SLOPE=1.000	CO ₂ slope, computed during zero/span calibration.
CO2OFFSET ⁷	CO2 OFFSET=0.000	CO ₂ offset, computed during zero/span calibration.
O2SLOPE ¹⁰	O2 SLOPE=0.980	O ₂ slope, computed during zero/span calibration.
O2OFFSET ¹⁰	O2 OFFSET=1.79 %	O ₂ offset, computed during zero/span calibration.
CO	CO=17.7 PPM ³	CO concentration for current range.
CO2 ⁷	CO2=15.0 %	CO ₂ concentration.
O2 ¹⁰	O2=0.00 %	O ₂ concentration.
TESTCHAN	TEST=1751.4 MV	Value output to <i>TEST_OUTPUT</i> analog output, selected with <i>TEST_CHAN_ID</i> variable.
XIN1 ¹²	AIN1=37.15 EU	External analog input 1 value in engineering units.
XIN2 ¹²	AIN2=37.15 EU	External analog input 2 value in engineering units.
XIN3 ¹²	AIN3=37.15 EU	External analog input 3 value in engineering units.
XIN4 ¹²	AIN4=37.15 EU	External analog input 4 value in engineering units.
XIN5 ¹²	AIN5=37.15 EU	External analog input 5 value in engineering units.
XIN6 ¹²	AIN6=37.15 EU	External analog input 6 value in engineering units.
XIN7 ¹²	AIN7=37.15 EU	External analog input 7 value in engineering units.
XIN8 ¹²	AIN8=37.15 EU	External analog input 8 value in engineering units.

Name ¹	Message Text	Description
CLOCKTIME	TIME=09:52:20	Current instrument time of day clock.
<p>¹ The name is used to request a message via the RS-232 interface, as in "T BOXTEMP"</p> <p>² Engineering software</p> <p>³ Current instrument units</p> <p>⁴ T300U, 300EU</p> <p>⁵ T300H, 300EH</p> <p>⁶ Except T360U, 360EU (APR version)</p> <p>⁷ M306E</p> <p>⁸ Sample pressure or differential pressure flow measurement option</p> <p>⁹ GFC7000E</p> <p>¹⁰ O₂ option</p> <p>¹¹ M300EU2, M320EU2</p> <p>¹² External analog input option.</p> <p>¹³ Except M300EU2 and M320EU configurations.</p>		

APPENDIX A-4: 300 Series Signal I/O Definitions, Revision L.8

M300E I/O Signal List for Latest Revision		
Signal Name	Bit or Channel Number	Description
Internal inputs, U7, J108, pins 9–16 = bits 0–7, default I/O address 322 hex		
SYNC_OK	0	1 = sync. OK 0 = sync. error
	1–7	Spare
Internal outputs, U8, J108, pins 1–8 = bits 0–7, default I/O address 322 hex		
ELEC_TEST	0	1 = electrical test on 0 = off
DARK_CAL	1	1 = dark calibration on 0 = off
	2–5	Spare
I2C_RESET	6	1 = reset I2C peripherals 0 = normal
I2C_DRV_RST	7	0 = hardware reset 8584 chip 1 = normal
Control inputs, U11, J1004, pins 1–6 = bits 0–5, default I/O address 321 hex		
EXT_ZERO_CAL	0	0 = go into zero calibration 1 = exit zero calibration
EXT_SPAN_CAL	1	0 = go into span calibration 1 = exit span calibration
REMOTE_RANGE_HI	2	0 = select high range during contact closure calibration 1 = select low range
	3–5	Spare
	6–7	Always 1
Control inputs, U14, J1006, pins 1–6 = bits 0–5, default I/O address 325 hex		
	0–5	Spare
	6–7	Always 1
Control outputs, U17, J1008, pins 1–8 = bits 0–7, default I/O address 321 hex		
	0–7	Spare
Control outputs, U21, J1008, pins 9–12 = bits 0–3, default I/O address 325 hex		
	0–3	Spare
Alarm outputs, U21, J1009, pins 1–12 = bits 4–7, default I/O address 325 hex		
ST_SYSTEM_OK2	4	1 = system OK 0 = any alarm condition or in diagnostics mode
ST_CONC_ALARM_1 ⁸	5	1 = conc. limit 1 exceeded 0 = conc. OK
ST_HIGH_RANGE ^{10 + 13}	5	1 = high auto-range in use 0 = low auto-range
ST_CONC_ALARM_2 ⁸	6	1 = conc. limit 2 exceeded 0 = conc. OK

ST_ZERO_CAL ¹⁰⁺¹³	6	1 = in zero calibration 0 = not in zero
ST_HIGH_RANGE2 ¹⁶	7	1 = high auto-range in use (mirrors ST_HIGH_RANGE status output) 0 = low auto-range
A status outputs, U24, J1017, pins 1–8 = bits 0–7, default I/O address 323 hex		
ST_SYSTEM_OK	0	0 = system OK 1 = any alarm condition
ST_CONC_VALID	1	0 = conc. valid 1 = hold off or other conditions
ST_HIGH_RANGE	2	0 = high auto-range in use 1 = low auto-range
ST_ZERO_CAL	3	0 = in zero calibration 1 = not in zero
ST_SPAN_CAL	4	0 = in span calibration 1 = not in span
ST_DIAG_MODE	5	0 = in diagnostic mode 1 = not in diagnostic mode
ST_AUTO_REF ³	6	0 = in auto-reference mode 1 = not in auto-reference mode
	7	Spare
B status outputs, U27, J1018, pins 1–8 = bits 0–7, default I/O address 324 hex		
ST_AUTO_REF ²	0	0 = in auto-reference mode 1 = not in auto-reference mode
	1–5	Spare
ST_CO2_CAL ⁷	6	0 = in CO ₂ calibration 1 = not in CO ₂ calibration
ST_O2_CAL ⁵	7	0 = in O ₂ calibration 1 = not in O ₂ calibration
Front panel I²C keyboard/touchscreen, default I²C address 4E hex		
MAINT_MODE	5 (input)	0 = maintenance mode 1 = normal mode
LANG2_SELECT	6 (input)	0 = select second language 1 = select first language (English)
SAMPLE_LED	8 (output)	0 = sample LED on 1 = off
CAL_LED	9 (output)	0 = cal. LED on 1 = off
FAULT_LED	10 (output)	0 = fault LED on 1 = off
AUDIBLE_BEEPER	14 (output)	0 = beeper on (for diagnostic testing only) 1 = off
Relay board digital output (PCF8574), default I²C address 44 hex		
RELAY_WATCHDOG	0	Alternate between 0 and 1 at least every 5 seconds to keep relay board active
WHEEL_HTR	1	0 = wheel heater on 1 = off

BENCH_HTR	2	0 = optical bench heater on 1 = off
O2_CELL_HEATER ⁵	3	0 = O ₂ sensor cell heater on 1 = off
BOX2_HEATER ³ , OVEN_HEATER ¹⁵	3	0 = internal box temperature #2/oven heater on 1 = off
CAL_VALVE	4	0 = let cal. gas in 1 = let sample gas in
SPAN_VALVE	5	0 = let span gas in 1 = let zero gas in
ZERO_SCRUB_VALVE ^{2,3}	6	0 = open zero scrubber valve 1 = close
SHUTOFF_VALVE	6 7 ^{3,15}	0 = energize shutoff valve 1 = de-energize
IR_SOURCE_ON	7 n/a ^{3,15}	0 = IR source on 1 = off
Rear board primary MUX analog inputs		
SAMPLE_PRESSURE	0	Sample pressure
VACUUM_PRESSURE ⁶	1	Vacuum pressure
PURGE_PRESSURE ^{9,10}	1	Purge pressure
CO_MEASURE	2	Detector measure reading
CO_REFERENCE	3	Detector reference reading
	4	Temperature MUX
SAMPLE_FLOW	5	Sample flow
PHOTO_TEMP	6	Photometer detector temperature
TEST_INPUT_7	7	Diagnostic test input
TEST_INPUT_8	8	Diagnostic test input
REF_4096_MV	9	4.096V reference from MAX6241
O2_SENSOR ⁵	10	O ₂ concentration sensor
	11	Spare
CO2_SENSOR ⁷	12	CO ₂ concentration sensor
	13	Spare
	14	DAC loopback MUX
REF_GND	15	Ground reference
Rear board temperature MUX analog inputs		
BOX_TEMP	0	Internal box temperature
SAMPLE_TEMP ¹⁸	1	Sample temperature
BENCH_TEMP	2	Optical bench temperature
WHEEL_TEMP	3	Wheel temperature
TEMP_INPUT_4	4	Diagnostic temperature input
TEMP_INPUT_5	5	Diagnostic temperature input
O2_CELL_TEMP ⁵	6	O ₂ sensor cell temperature
BOX2_TEMP ³ OVEN_TEMP ^{19,23}	6	Internal box temperature #2 / oven temperature
	7	Spare

Rear board DAC MUX analog inputs		
DAC_CHAN_1	0	DAC channel 0 loopback
DAC_CHAN_2	1	DAC channel 1 loopback
DAC_CHAN_3	2	DAC channel 2 loopback
DAC_CHAN_4	3	DAC channel 3 loopback
Rear board analog outputs		
CONC_OUT_1, DATA_OUT_1	0	Concentration output #1 (CO, range #1), Data output #1
CONC_OUT_2, DATA_OUT_2	1	Concentration output #2 (CO, range #2), Data output #2
CONC_OUT_3, ^{7,5} DATA_OUT_3	2	Concentration output #3 (CO ₂ or O ₂), Data output #3
TEST_OUTPUT, DATA_OUT_4	3	Test measurement output, Data output #4
External analog input board, default I²C address 5C hex		
XIN1 ¹⁷	0	External analog input 1
XIN2 ¹⁷	1	External analog input 2
XIN3 ¹⁷	2	External analog input 3
XIN4 ¹⁷	3	External analog input 4
XIN5 ¹⁷	4	External analog input 5
XIN6 ¹⁷	5	External analog input 6
XIN7 ¹⁷	6	External analog input 7
XIN8 ¹⁷	7	External analog input 8
¹ Hessen protocol ² T300H, 300EH ³ T300U, 300EU ⁴ M320E ⁵ O ₂ option ⁶ Sample pressure or differential pressure flow measurement option ⁷ CO ₂ option ⁸ Concentration alarms option ⁹ T360, 360E ¹⁰ GFC7000E ¹¹ T300M, 300EM ¹³ Air Products special #1 ¹⁴ Air Products special #2 ¹⁵ M300EU2 ¹⁶ High auto range relay option ¹⁷ External analog input option. ¹⁸ Except M300EU2 and M320EU configurations.		

APPENDIX A-5: 300 Series DAS Triggering Events, Revision L.8

Name	Description
ATIMER	Automatic timer expired
EXITZR	Exit zero calibration mode
EXITSP	Exit span calibration mode
EXITMP	Exit multi-point calibration mode
EXITC2 ⁵	Exit CO ₂ calibration mode
SLPCHG	Slope and offset recalculated
CO2SLC ⁵	CO ₂ slope and offset recalculated
O2SLPC ⁷	O ₂ slope and offset recalculated
EXITDG	Exit diagnostic mode
SOURCW	Source warning
AZEROW ^{1,2}	Auto-zero warning
CONCW1 ^{1,3,4}	Concentration limit 1 exceeded
CONCW2 ^{1,3,4}	Concentration limit 2 exceeded
SYNCW	Sync warning
BNTMPW	Bench temperature warning
WTEMPW	Wheel temperature warning
O2TMPW ⁷	O ₂ sensor cell temperature warning
STEMPW ⁹	Sample temperature warning
SFLOWW ⁶	Sample flow warning
SPRESW	Sample pressure warning
PPRESW ⁴	Purge pressure warning
BTEMPW	Internal box temperature warning
BTMP2W ² , OVTMPW ⁸	Internal box temperature #2/oven warning
PTEMPW	Photometer detector temperature warning
¹ T300H, 300EH ² T300U, 300EU ³ M320E ⁴ GFC7000E ⁵ M306E ⁶ Except T360U, 360EU (APR version) ⁷ O ₂ option ⁸ M300EU2, M320EU2 ⁹ Except M300EU2 and M320EU configurations.	

APPENDIX A-6: DAS Parameters, Revision L.8

Name	Description	Units
DETMES	Detector measure reading	mV
DETRF	Detector reference reading	mV
RATIO	M/R ratio.	none
SLOPE1	Slope for range #1	none
SLOPE2	Slope for range #2	none
OFSET1	Offset for range #1	none
OFSET2	Offset for range #2	none
CO2SLP ⁵	CO ₂ slope	none
CO2OFS ⁵	CO ₂ offset	%
O2SLPE ⁸	O ₂ slope	none
O2OFST ⁸	O ₂ offset	%
AZERO ^{1,2}	Auto-zero reading	M/R
ZSCNC1	Concentration for range #1 during zero/span calibration, just before computing new slope and offset	PPM
ZSCNC2	Concentration for range #2 during zero/span calibration, just before computing new slope and offset	PPM
CO2ZSC ⁵	CO ₂ concentration during zero/span calibration, just before computing new slope and offset	%
O2ZSCN ⁸	O ₂ concentration during zero/span calibration, just before computing new slope and offset	%
CONC1	Concentration for range #1	PPM
CONC2	Concentration for range #2	PPM
CO2CNC ⁵	CO ₂ concentration	%
O2CONC ⁸	O ₂ concentration	%
STABIL	Concentration stability	PPM
BNTEMP	Bench temperature	°C
BNCDTY	Bench temperature control duty cycle	Fraction (0.0 = off, 1.0 = on full)
WTEMP	Wheel temperature	°C
WHLDTY	Wheel temperature control duty cycle	Fraction (0.0 = off, 1.0 = on full)
O2TEMP ⁸	O ₂ sensor cell temperature	°C
SMPTMP ¹¹	Sample temperature	°C
SMPFLW ⁶	Sample flow	cc/m
SMPPRS	Sample pressure	"Hg
VACUUM ^{1,3,6}	Vacuum pressure	"Hg
PRGPRS ⁴	Purge pressure	PSIG

Name	Description	Units
BOXTMP	Internal box temperature	°C
BX2TMP ² , OVNTMP ⁹	Internal box temperature #2/oven	°C
BX2DTY ² , OVNDTY ⁹	Internal box temperature #2/oven control duty cycle	Fraction (0.0 = off, 1.0 = on full)
PHTDRV	Photometer detector temperature drive	mV
TEST7	Diagnostic test input (TEST_INPUT_7)	mV
TEST8	Diagnostic test input (TEST_INPUT_8)	mV
TEMP4	Diagnostic temperature input (TEMP_INPUT_4)	°C
TEMP5	Diagnostic temperature input (TEMP_INPUT_5)	°C
REFGND	Ground reference (REF_GND)	mV
RF4096	4096 mV reference (REF_4096_MV)	mV
XIN1 ¹⁰	External analog input 1 value	Volts
XIN1SLPE ¹⁰	External analog input 1 slope	eng unit / V
XIN1OFST ¹⁰	External analog input 1 value	eng unit
XIN2 ¹⁰	External analog input 2 value	Volts
XIN2SLPE ¹⁰	External analog input 2 slope	eng unit / V
XIN2OFST ¹⁰	External analog input 2 value	eng unit
XIN3 ¹⁰	External analog input 3 value	Volts
XIN3SLPE ¹⁰	External analog input 3 slope	eng unit / V
XIN3OFST ¹⁰	External analog input 3 value	eng unit
XIN4 ¹⁰	External analog input 4 value	Volts
XIN4SLPE ¹⁰	External analog input 4 slope	eng unit / V
XIN4OFST ¹⁰	External analog input 4 value	eng unit
XIN5 ¹⁰	External analog input 5 value	Volts
XIN5SLPE ¹⁰	External analog input 5 slope	eng unit / V
XIN5OFST ¹⁰	External analog input 5 value	eng unit
XIN6 ¹⁰	External analog input 6 value	Volts
XIN6SLPE ¹⁰	External analog input 6 slope	eng unit / V
XIN6OFST ¹⁰	External analog input 6 value	eng unit
XIN7 ¹⁰	External analog input 7 value	Volts
XIN7SLPE ¹⁰	External analog input 7 slope	eng unit / V
XIN7OFST ¹⁰	External analog input 7 value	eng unit
XIN8 ¹⁰	External analog input 8 value	Volts
XIN8SLPE ¹⁰	External analog input 8 slope	eng unit / V
XIN8OFST ¹⁰	External analog input 8 value	eng unit

Name	Description	Units
1 T300H, 300EH		
2 T300U, 300EU		
3 M320E		
4 GFC7000E		
5 M306E		
6 Except T360U, 360EU (APR version)		
7	The units, including the concentration units, are always fixed, regardless of the current instrument units	
8	O ₂ option	
9	M300EU2, M320EU2	
10	External analog input option.	
11	Except M300EU2 and M320EU configurations.	

APPENDIX A-7: Terminal Command Designators

COMMAND	ADDITIONAL COMMAND SYNTAX	DESCRIPTION
? [ID]		Display help screen and commands list
LOGON [ID]	password	Establish connection to instrument
LOGOFF [ID]		Terminate connection to instrument
T [ID]	SET ALL name hexmask	Display test(s)
	LIST [ALL name hexmask] [NAMES HEX]	Print test(s) to screen
	name	Print single test
	CLEAR ALL name hexmask	Disable test(s)
W [ID]	SET ALL name hexmask	Display warning(s)
	LIST [ALL name hexmask] [NAMES HEX]	Print warning(s)
	name	Clear single warning
	CLEAR ALL name hexmask	Clear warning(s)
C [ID]	ZERO LOWSPAN SPAN [1 2]	Enter calibration mode
	ASEQ number	Execute automatic sequence
	COMPUTE ZERO SPAN	Compute new slope/offset
	EXIT	Exit calibration mode
	ABORT	Abort calibration sequence
D [ID]	LIST	Print all I/O signals
	name[=value]	Examine or set I/O signal
	LIST NAMES	Print names of all diagnostic tests
	ENTER name	Execute diagnostic test
	EXIT	Exit diagnostic test
	RESET [DATA] [CONFIG] [exitcode]	Reset instrument
	PRINT ["name"] [SCRIPT]	Print iDAS configuration
	RECORDS ["name"]	Print number of iDAS records
	REPORT ["name"] [RECORDS=number] [FROM=<start date>][TO=<end date>][VERBOSE COMPACT HEX] (Print DAS records)(date format: MM/DD/YYYY(or YY) [HH:MM:SS])	Print iDAS records
CANCEL	Halt printing iDAS records	
V [ID]	LIST	Print setup variables
	name[=value [warn_low [warn_high]]]	Modify variable
	name="value"	Modify enumerated variable
	CONFIG	Print instrument configuration
	MAINT ON OFF	Enter/exit maintenance mode
	MODE	Print current instrument mode
	DASBEGIN [<data channel definitions>] DASEND	Upload iDAS configuration
	CHANNELBEGIN propertylist CHANNELEND	Upload single iDAS channel
	CHANNELDELETE ["name"]	Delete iDAS channels

The command syntax follows the command type, separated by a space character. Strings in [brackets] are optional designators. The following key assignments also apply.

Appendix A-8: Terminal Key Assignments

TERMINAL KEY ASSIGNMENTS	
ESC	Abort line
CR (ENTER)	Execute command
Ctrl-C	Switch to computer mode
COMPUTER MODE KEY ASSIGNMENTS	
LF (line feed)	Execute command
Ctrl-T	Switch to terminal mode

Appendix A-9: MODBUS Register Map

MODBUS Register Address (dec., 0-based)	Description	Units
MODBUS Floating Point Input Registers (32-bit IEEE 754 format; read in high-word, low-word order; read-only)		
0	Detector measure reading	mV
2	Detector reference reading	mV
4	M/R ratio.	none
6	Slope for range #1	none
8	Slope for range #2	none
10	Offset for range #1	none
12	Offset for range #2	none
14	Concentration for range #1 during zero/span calibration, just before computing new slope and offset	PPM
16	Concentration for range #2 during zero/span calibration, just before computing new slope and offset	PPM
18	Concentration for range #1	PPM
20	Concentration for range #2	PPM
22	Concentration stability	PPM
24	Bench temperature	°C
26	Bench temperature control duty cycle	Fraction (0.0 = off, 1.0 = on full)
28	Wheel temperature	°C
30	Wheel temperature control duty cycle	Fraction (0.0 = off, 1.0 = on full)
32 ¹¹	Sample temperature	°C
34	Sample pressure	"Hg
36	Internal box temperature	°C
38	Photometer detector temperature drive	mV
40	Diagnostic test input (TEST_INPUT_7)	mV
42	Diagnostic test input (TEST_INPUT_8)	mV
44	Diagnostic temperature input (TEMP_INPUT_4)	°C

MODBUS Register Address (dec., 0-based)	Description	Units
46	Diagnostic temperature input (TEMP_INPUT_5)	°C
48	Ground reference (REF_GND)	mV
50	4096 mV reference (REF_4096_MV)	mV
52 ¹	Purge pressure	PSIG
54 ¹	Sample flow	cc/m
56 ¹	Vacuum pressure	"Hg
58 ¹	Internal box temperature #2/oven	°C
60 ¹	Internal box temperature #2/oven control duty cycle	Fraction (0.0 = off, 1.0 = on full)
62 ¹	Auto-zero reading	M/R
100 ²	O ₂ concentration	%
102 ²	O ₂ concentration during zero/span calibration, just before computing new slope and offset	%
104 ²	O ₂ slope	—
106 ²	O ₂ offset	%
108 ²	O ₂ sensor cell temperature	°C
130 ¹⁰	External analog input 1 value	Volts
132 ¹⁰	External analog input 1 slope	eng unit /V
134 ¹⁰	External analog input 1 offset	eng unit
136 ¹⁰	External analog input 2 value	Volts
138 ¹⁰	External analog input 2 slope	eng unit /V
140 ¹⁰	External analog input 2 offset	eng unit
142 ¹⁰	External analog input 3 value	Volts
144 ¹⁰	External analog input 3 slope	eng unit /V
146 ¹⁰	External analog input 3 offset	eng unit
148 ¹⁰	External analog input 4 value	Volts
150 ¹⁰	External analog input 4 slope	eng unit /V
152 ¹⁰	External analog input 4 offset	eng unit
154 ¹⁰	External analog input 5 value	Volts
156 ¹⁰	External analog input 5 slope	eng unit /V
158 ¹⁰	External analog input 5 offset	eng unit
160 ¹⁰	External analog input 6 value	Volts
162 ¹⁰	External analog input 6 slope	eng unit /V
164 ¹⁰	External analog input 6 offset	eng unit
166 ¹⁰	External analog input 7 value	Volts
168 ¹⁰	External analog input 7 slope	eng unit /V
170 ¹⁰	External analog input 7 offset	eng unit
172 ¹⁰	External analog input 8 value	Volts
174 ¹⁰	External analog input 8 slope	eng unit /V
176 ¹⁰	External analog input 8 offset	eng unit
200 ³	CO ₂ concentration	%

MODBUS Register Address (dec., 0-based)	Description	Units
202 ³	CO ₂ concentration during zero/span calibration, just before computing new slope and offset	%
204 ³	CO ₂ slope	—
206 ³	CO ₂ offset	%
MODBUS Floating Point Holding Registers (32-bit IEEE 754 format; read/write in high-word, low-word order; read/write)		
0	Maps to CO_SPAN1 variable; target conc. for range #1	Conc. units
2	Maps to CO_SPAN2 variable; target conc. for range #2	Conc. units
100 ²	Maps to O2_TARG_SPAN_CONC variable	%
200 ³	Maps to CO2_TARG_SPAN_CONC variable	%
MODBUS Discrete Input Registers (single-bit; read-only)		
0	Source warning	
1	Box temperature warning	
2	Bench temperature warning	
3	Wheel temperature warning	
4 ¹¹	Sample temperature warning	
5	Sample pressure warning	
6	Photometer detector temperature warning	
7	System reset warning	
8	Rear board communication warning	
9	Relay board communication warning	
10	Front panel communication warning	
11	Analog calibration warning	
12	Dynamic zero warning	
13	Dynamic span warning	
14	Invalid concentration	
15	In zero calibration mode	
16	In span calibration mode	
17	In multi-point calibration mode	
18	System is OK (same meaning as SYSTEM_OK I/O signal)	
19 ¹	Purge pressure warning	
20 ¹	Sample flow warning	
21 ¹	Internal box temperature #2/oven warning	
22 ¹	Concentration limit 1 exceeded	
23 ¹	Concentration limit 2 exceeded	
24 ¹	Auto-zero warning	
25 ¹	Sync warning	
26 ¹	In Hessen manual mode	
100 ²	In O ₂ calibration mode	
101 ²	O ₂ cell temperature warning	
102 ^{1,2}	O ₂ concentration limit 1 exceeded	

MODBUS Register Address (dec., 0-based)	Description	Units
103 ^{1,2}	O ₂ concentration limit 2 exceeded	
200 ³	In CO ₂ calibration mode	
201 ^{1,3}	CO ₂ concentration limit 1 exceeded	
202 ^{1,3}	CO ₂ concentration limit 2 exceeded	
MODBUS Coil Registers (single-bit; read/write)		
0	Maps to relay output signal 36 (<i>MB_RELAY_36</i> in signal I/O list)	
1	Maps to relay output signal 37 (<i>MB_RELAY_37</i> in signal I/O list)	
2	Maps to relay output signal 38 (<i>MB_RELAY_38</i> in signal I/O list)	
3	Maps to relay output signal 39 (<i>MB_RELAY_39</i> in signal I/O list)	
20 ⁴	Triggers zero calibration of range #1 (on enters cal.; off exits cal.)	
21 ⁴	Triggers span calibration of range #1 (on enters cal.; off exits cal.)	
22 ⁴	Triggers zero calibration of range #2 (on enters cal.; off exits cal.)	
23 ⁴	Triggers span calibration of range #2 (on enters cal.; off exits cal.)	
<p>¹ Optional</p> <p>² O₂ option</p> <p>³ CO₂ option</p> <p>⁴ Set <i>DYN_ZERO</i> or <i>DYN_SPAN</i> variables to <i>ON</i> to enable calculating new slope or offset. Otherwise a calibration check is performed.</p> <p>¹⁰ External analog input option.</p> <p>¹¹ Except T300U, 300EU2 and M320EU configurations.</p>		

APPENDIX B - Spare Parts

Note Use of replacement parts other than those supplied by Teledyne Advanced Pollution Instrumentation (TAPI) may result in non-compliance with European standard EN 61010-1.

Note Due to the dynamic nature of part numbers, please refer to the TAPI Website at <http://www.teledyne-api.com> or call Customer Service at 800-324-5190 for more recent updates to part numbers.

This page intentionally left blank.

T360 Spare Parts List

053900000

1/4/2011 10:02

PARTNUMBER	DESCRIPTION
000941000	CD, ORIFICE, .013 BLUE/GREEN
001760400	ASSY, FLOW CTL, 800CC, 1/4" CONN-B
001761300	ASSY, FLOW CTRL, .010, 1/8", SS
003290500	ASSY, THERMISTOR, BENCH
003291500	ASSY, THERMISTOR, BENCH/WHEEL
006110200	ASSY, MOTOR WHEEL HEATER
006900000	RETAINER PAD CHARCOAL, SMALL, 1-3/4"
009450300	ASSY, ZERO/SPAN VALVES, CO
009550500	ASSY, SOURCE
009560201	GF WHEEL, CO2, (KB)
009600400	AKIT, EXPENDABLES, CO
009690000	AKIT, TFE FLTR ELEM (FL6 100=1) 47mm
009690100	AKIT, TFE FLTR ELEM (FL6, 30=1) 47mm
009840300	ASSY, SHUT-OFF VALVE, (KB)
010790000	INPUT MIRROR, REPLICATED(KB)
010800000	OUTPUT MIRROR, REPLICATED(KB)
016290000	WINDOW, SAMPLE FILTER, 47MM (KB)
016300600	ASSY, SAMPLE FILTER, 47MM, ANG BKT, 5UM
019340200	ASSY, SAMPLE THERMISTOR, BRASS
026060000	MIRROR, OBJECTIVE, 8 PASS
026070000	MIRROR, FIELD, 8 PASS
035280000	ASSY, SCRUBBER, CO2, CH47
036110300	PCA, SYNC DEMOD, CO2 (BT-KB)
037250100	ASSY, BAND HEATER W/TC
037600000	AKIT, EXP KIT, SODA LIME CH47
037860000	ORING, TEFLON, RETAINING RING, 47MM (KB)
040010000	ASSY, FAN REAR PANEL
040030100	PCA, PRESS SENSORS (1X), w/FM4
041350000	PCA, RELAY BOARD, CO
042410100	ASSY, PUMP, INT, (CO) W/ 800CC FLOW
042410200	ASSY, PUMP, INT, SOX/O3/IR *
042680000	ASSY, VALVE (SS)
042690000	ASSY, VALVE , 2-WAY, 12V
042890100	ASSY, PUMP CONFIG PLUG, 100-115V/60 HZ
042900100	PROGRAMMED FLASH
043250100	ASSY, PWR CONF, 100-120V/60HZ, CO
043250300	OPTION, PWR CONF, 220-240V/50HZ, CO
043250400	OPTION, PWR CONF, 220-240V/60HZ, CO
043940000	PCA, INTERFACE, ETHERNET
045830000	ASSY, CO2 SENSOR, (BF/KB)
045930000	ASSY, PURGE REGULATOR
048620200	PCA, SERIAL INTERFACE, w/ MD
050110000	THERMAL PAD, HEATSINK, CENTER
052560000	PCA, OPTO-INTERRUPTER
052830200	ASSY, MOTOR HUB, MR7
053230000	AKIT, EXPENDABLES, M360E IZS (w OPT 42C)
055010000	ASSY, MTR WHL HEATER w/THERM, 200W
055100200	ASSY, OPTION, PUMP, 240V *
058021100	PCA, MOTHERBD, GEN 5-ICOP

T360 Spare Parts List

PARTNUMBER	DESCRIPTION
066970000	INTRF. LCD TOUCH SCRNR, F/P
067240000	CPU, PC-104, VSX-6154E, ICOP *
067300100	PCA, AUX-I/O BOARD, ETHERNET
067390000	CBL, CPU ETHERNET TO AUX I/O PCA
067410000	CPU USB TO FRONT PANEL, T-SERIES
068010000	ASSY, PS37 W/#2 PIN REMOVED
068020000	ASSY, PS38 W/#6 PIN REMOVED*
072150000	ASSY. TOUCHSCREEN CONTROL MODULE
072720000	MANUAL,T360, OPERATORS
073660100	DOM, w/SOFTWARE, T360 *
CN0000458	PLUG, 12, MC 1.5/12-ST-3.81 (KB)
CN0000520	PLUG, 10, MC 1.5/10-ST-3.81 (KB)
FL0000001	FILTER, SS (KB)
FL0000003	FILTER, DFU (KB)
FM0000004	FLOWMETER (KB)
HW0000020	SPRING
HW0000036	TFE TAPE, 1/4" (48 FT/ROLL)
HW0000090	SPRING, SS, LONG
HW0000101	ISOLATOR
HW0000379	SEAL, GFC MOTOR
HW0000453	SUPPORT, CIRCUIT BD, 3/16" ICOP
KIT000219	AKIT, 4-20MA CURRENT OUTPUT
OP0000009	WINDOW (KB)
OR0000001	ORING, 2-006VT *(KB)
OR0000002	ORING, 2-023V
OR0000025	ORING, 2-133V
OR0000034	ORING, 2-011V FT10
OR0000039	ORING, 2-012V
OR0000041	ORING, 2-136V
OR0000047	ORING, 2-007V
OR0000077	ORING, 2-018V
OR0000088	ORING, 2-011S, 40 DURO
OR0000094	ORING, 2-228V, 50 DURO VITON(KB)
OR0000096	ORING, 2-532V
OR0000097	ORING, 2-119S
PU0000022	REBUILD KIT, FOR PU20 & 04241 (KB)
RL0000015	RELAY, DPDT, (KB)
SW0000051	SWITCH, POWER CIRC BREAK VDE/CE, w/RG(KB)
SW0000059	PRESSURE SENSOR, 0-15 PSIA, ALL SEN
VA0000014	REGULATOR
WR0000008	POWER CORD, 10A(KB)

044110000

11/19/2010 18:13

PARTNUMBER	DESCRIPTION
003290500	ASSY, THERMISTOR, BENCH
009550500	ASSY, SOURCE
037250100	ASSY, BAND HEATER W/TC
040010000	ASSY, FAN REAR PANEL
040030100	PCA, PRESS SENSORS (1X), w/FM4
042410200	ASSY, PUMP, INT, SOX/O3/IR *
042580000	PCA, KEYBOARD, W/V-DETECT
042680000	ASSY, VALVE (SS)
042690000	ASSY, VALVE , 2-WAY, 12V
052560000	PCA, OPTO-INTERRUPTER
052840200	ASSY, MOTOR HUB, MR7, PURGED, "E", 115V
055010000	ASSY, MTR WHL HEATER w/THERM, 200W
055100200	ASSY, OPTION, PUMP, 240V *
058021100	PCA, MOTHERBD, GEN 5-ICOP
062870000	CPU, PC-104, VSX-6150E, ICOP (KB)*
DS0000025	DISPLAY(KB)
KIT000159	REPLACEMENT, RELAY BD, M300E, SN >= 100
KIT000180	RETROFIT, SYNC DMOD UPDATE, M360E
KIT000183	REPLACE, CO2 FILTER WHEEL ASSY, E-SERIES
PS0000011	PWR SUPPLY, SW, +5V, +/-15V, 40W (KB)
PS0000025	PWR SUPPLY, SW, 12V, 40W (KB)
RL0000015	RELAY, DPDT, (KB)

This page intentionally left blank.

Appendix C
Warranty/Repair Questionnaire
T360, M360E
 (05235C DCN5798)



CUSTOMER: _____ PHONE: _____
 CONTACT NAME: _____ FAX NO: _____
 SITE ADDRESS: _____
 SERIAL NO.: _____ FIRMWARE REVISION: _____

1. Are there any failure messages? _____

Please complete the following table:

PARAMETER	DISPLAYED AS	OBSERVED VALUE	UNITS	NOMINAL RANGE
Range	RANGE		PPM	0 -10, 0 - 2000 Ppm
Stability	STABIL		PPM	≤ 0.15 Ppm With Zero Air
CO ₂ Measure	CO2 MEAS		mV	3600 – 4800 Mv
CO ₂ Reference	CO2 REF		mV	1400 – 2000 Mv
Measure/Reference Ratio	MR RATIO			2.5 ± 0.02 W/ Zero Air
Pressure	PRES		INHG	-2" Ambient Absolute
Sample Flow	SAMP FL		CC	800 ± 10%
Sample Temp	SAMPLE TEMP		°C	48 ± 4
Bench Temp	BENCH TEMP		°C	48 ± 2
Wheel Temp	WHEEL TEMP		°C	68 ± 2
Box Temp	BOX TEMP		°C	Ambient + 7 ± 10
Photo Drive	PHT DRIVE		mV	250 Mv TO 4750 Mv
Slope	SLOPE		.	1.0 ± .3
Offset	OFFSET			0 ± 0.3
O ₂ Sensor Temperature ³	O2 CELL TEMP		°C	50 ± 5
Slope of O ₂ Measurement ³	O2 SLOPE			
Offset of O ₂ Measurement ³	O2 OFFSET			
Dark Cal Reference signal	REF DARK OFFSET		mV	125 ± 50 Mv.
Dark Cal Measurement Signal	MEAS DARK OFFSET		mV	125 ± 50 Mv
Electric Test			PPM	40 ± 2 Ppm
Values are in the Signal I/O				
REF_4096_MV				4096mv±2mv And Must Be Stable
REF_GND				0± 0.5 And Must Be Stable

2. Have you performed a leak check and flow check? _____

3. What is the sample flow & sample pressure with the sample in-let on rear of machine capped?

SAMPLE FLOW _____ CC SAMPLE PRESSURE _____ IN-HG-A

TELEDYNE API CUSTOMER SERVICE
 Email: api-customerservice@teledyne.com

PHONE: (858) 657-9800 TOLL FREE: (800) 324-5190 FAX: (858) 657-9816

3. What are the failure symptoms? _____

4. What test have you done trying to solve the problem? _____

5. Please check these signals and verify the correctness. Look for the signals annotated on the diagram. What are the peak-to-peak voltages?

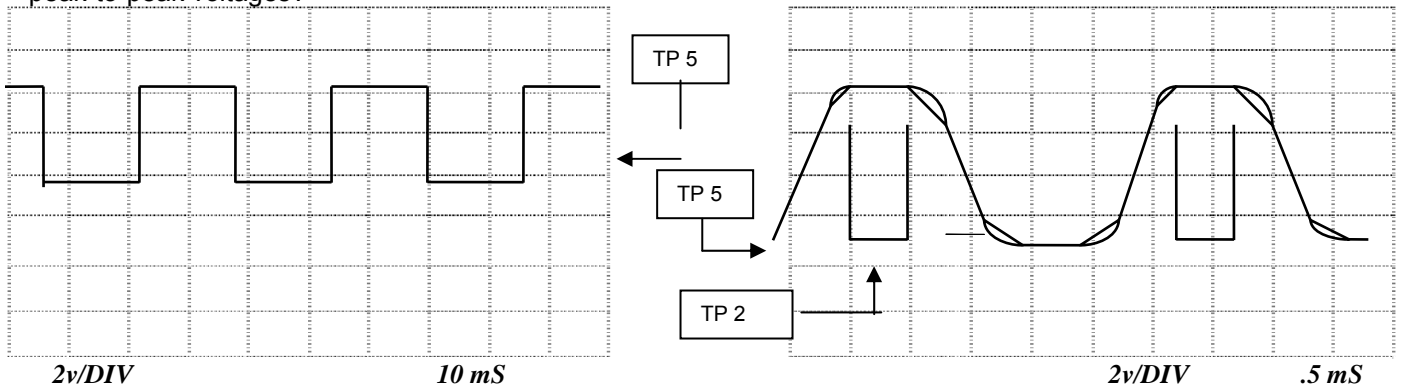

5. If possible, please include a portion of a strip chart pertaining to the problem. Circle pertinent data.

Thank you for providing this information. Your assistance enables Teledyne API to respond faster to the problem that you are encountering.

OTHER INFORMATION: _____

APPENDIX D – Wire List and Electronic Schematics

This page intentionally left blank.

Interconnect List, T300/M T360/M

(Reference 0691201B DCN5947)

Cable PN	Signal	Assembly	FROM			TO			
			PN	J/P	Pin	Assembly	PN	J/P	Pin
03995	CBL, MOTOR TO RELAY PCA								
	GFC Drive - A	Relay PCA	041350000	J6	1	GFC Motor	052380200	P1	1
	GFC Drive - B	Relay PCA	041350000	J6	2	GFC Motor	052380200	P1	2
	Motor Return	Relay PCA	041350000	J6	3	GFC Motor	052380200	P1	3
	Chassis Gnd	Relay PCA	041350000	J6	4	GFC Motor	052380200	P1	4
04103	CBL, MOTHERBOARD TO THERMISTORS								
	+5V Ref	Motherboard	058021100	J27	6	Bench Temp Snsr	003291500	P1	1
	Bench Temp	Motherboard	058021100	J27	13	Bench Temp Snsr	003291500	P1	2
	+5V Ref	Motherboard	058021100	J27	5	Wheel Temp Snsr	003291500	P1	1
	Wheel Temp	Motherboard	058021100	J27	12	Wheel Temp Snsr	003291500	P1	2
	+5V ref	Motherboard	058021100	J27	1	Shield			
	+5V Ref	Motherboard	058021100	J27	7	Sample Temp Snsr	019340200, -06	P1	1
	Sample Temp	Motherboard	058021100	J27	14	Sample Temp Snsr	019340200, -06	P1	2
		Motherboard	058021100	J27	2	O2 Sensor Therm/Htr	043420000	P1	3
		Motherboard	058021100	J27	9	O2 Sensor Therm/Htr	043420000	P1	1
		Relay PCA	041350000	J4	1	O2 Sensor Therm/Htr	043420000	P1	4
		Relay PCA	041350000	J4	2	O2 Sensor Therm/Htr	043420000	P1	2
		Relay PCA	041350000	J4	3	Shield			
04105	CBL, LCD INTERFACE PCA TO MOTHERBOARD								
	Kbd Interupt	LCD Interface PCA	066970000	J1	7	Motherboard	058021100	J106	1
	DGND	LCD Interface PCA	066970000	J1	2	Motherboard	058021100	J106	8
	SDA	LCD Interface PCA	066970000	J1	5	Motherboard	058021100	J106	2
	SCL	LCD Interface PCA	066970000	J1	6	Motherboard	058021100	J106	6
	Shld	LCD Interface PCA	066970000	J1	10	Motherboard	058021100	J106	5
04146	CBL, SYNC DEMOD								
	DGND	Opto Pickup	05032 or 05256	J2	1	Sync Demod	032960000	JP4	6
	Segment Gate	Opto Pickup	05032 or 05256	J2	2	Sync Demod	032960000	JP4	5
	No Connection	Opto Pickup	05032 or 05256	J2	3	Sync Demod	032960000	JP4	4
	DGND	Opto Pickup	05032 or 05256	J2	4	Sync Demod	032960000	JP4	3
	M/R Gate	Opto Pickup	05032 or 05256	J2	5	Sync Demod	032960000	JP4	2
	+5V	Opto Pickup	05032 or 05256	J2	6	Sync Demod	032960000	JP4	1
04237	CBL ASSY, 12V VALVE CBLS								
	+12	Relay PCA	041350000	J7	6	Zero/Span Vlv	042680000	P1	1
	Zero/Span Drv	Relay PCA	041350000	J7	8	Zero/Span Vlv	042680000	P1	2
	+12	Relay PCA	041350000	J7	2	Samp/Cal Vlv	042680000	P1	1
	Samp/Cal Drv	Relay PCA	041350000	J7	4	Samp/Cal Vlv	042680000	P1	2
	+12	Relay PCA	041350000	J7	5	Shutoff Valve	042690000	P1	1
	Shutoff Vlv	Relay PCA	041350000	J7	7	Shutoff Valve	042690000	P1	2
04671	CBL, MOTHERBOARD TO XMITTER BD (MULTIDROP OPTION)								
	GND	Motherboard	058021100	P12	2	Xmitter bd w/Multidrop	069500000	J4	2
	RX0	Motherboard	058021100	P12	14	Xmitter bd w/Multidrop	069500000	J4	14
	RTS0	Motherboard	058021100	P12	13	Xmitter bd w/Multidrop	069500000	J4	13
	TX0	Motherboard	058021100	P12	12	Xmitter bd w/Multidrop	069500000	J4	12
	CTS0	Motherboard	058021100	P12	11	Xmitter bd w/Multidrop	069500000	J4	11
	RS-GND0	Motherboard	058021100	P12	10	Xmitter bd w/Multidrop	069500000	J4	10
	RTS1	Motherboard	058021100	P12	8	Xmitter bd w/Multidrop	069500000	J4	8
	CTS1/485-	Motherboard	058021100	P12	6	Xmitter bd w/Multidrop	069500000	J4	6
	RX1	Motherboard	058021100	P12	9	Xmitter bd w/Multidrop	069500000	J4	9
	TX1/485+	Motherboard	058021100	P12	7	Xmitter bd w/Multidrop	069500000	J4	7
	RS-GND1	Motherboard	058021100	P12	5	Xmitter bd w/Multidrop	069500000	J4	5
	RX1	Motherboard	058021100	P12	9	Xmitter bd w/Multidrop	069500000	J4	9
	TX1/485+	Motherboard	058021100	P12	7	Xmitter bd w/Multidrop	069500000	J4	7
	RS-GND1	Motherboard	058021100	P12	5	Xmitter bd w/Multidrop	069500000	J4	5
06737	CBL, I2C TO AUX I/O PCA (ANALOG IN OPTION)								
	ATX-	Motherboard	058021100	J106	1	AUX I/O PCA	067300000	J2	1
	ATX+	Motherboard	058021100	J106	2	AUX I/O PCA	067300000	J2	2
	LED0	Motherboard	058021100	J106	3	AUX I/O PCA	067300000	J2	3
	ARX+	Motherboard	058021100	J106	4	AUX I/O PCA	067300000	J2	4
	ARX-	Motherboard	058021100	J106	5	AUX I/O PCA	067300000	J2	5
	LED0+	Motherboard	058021100	J106	6	AUX I/O PCA	067300000	J2	6
	LED1+	Motherboard	058021100	J106	8	AUX I/O PCA	067300000	J2	8
06738	CBL, CPU COM to AUX I/O (USB OPTION)								
	RXD1	CPU PCA	067240000	COM1	1	AUX I/O PCA	0673000 or -02	J3	1
	DCD1	CPU PCA	067240000	COM1	2	AUX I/O PCA	0673000 or -02	J3	2
	DTR1	CPU PCA	067240000	COM1	3	AUX I/O PCA	0673000 or -02	J3	3
	TXD1	CPU PCA	067240000	COM1	4	AUX I/O PCA	0673000 or -02	J3	4
	DSR1	CPU PCA	067240000	COM1	5	AUX I/O PCA	0673000 or -02	J3	5
	GND	CPU PCA	067240000	COM1	6	AUX I/O PCA	0673000 or -02	J3	6
	CTS1	CPU PCA	067240000	COM1	7	AUX I/O PCA	0673000 or -02	J3	7
	RTS1	CPU PCA	067240000	COM1	8	AUX I/O PCA	0673000 or -02	J3	8
	RI1	CPU PCA	067240000	COM1	10	AUX I/O PCA	0673000 or -02	J3	10

Interconnect List, T300/M T360/M

(Reference 0691201B DCN5947)

Cable PN	Signal	Assembly	FROM			TO			
			PN	J/P	Pin	Assembly	PN	J/P	Pin
06738	CBL, CPU COM to AUX I/O (MULTIDROP OPTION)								
	RXD	CPU PCA	067240000	COM1	1	Xmitter bd w/Multidrop	069500000	J3	1
	DCD	CPU PCA	067240000	COM1	2	Xmitter bd w/Multidrop	069500000	J3	2
	DTR	CPU PCA	067240000	COM1	3	Xmitter bd w/Multidrop	069500000	J3	3
	TXD	CPU PCA	067240000	COM1	4	Xmitter bd w/Multidrop	069500000	J3	4
	DSR	CPU PCA	067240000	COM1	5	Xmitter bd w/Multidrop	069500000	J3	5
	GND	CPU PCA	067240000	COM1	6	Xmitter bd w/Multidrop	069500000	J3	6
	CTS	CPU PCA	067240000	COM1	7	Xmitter bd w/Multidrop	069500000	J3	7
	RTS	CPU PCA	067240000	COM1	8	Xmitter bd w/Multidrop	069500000	J3	8
	RI	CPU PCA	067240000	COM1	10	Xmitter bd w/Multidrop	069500000	J3	10
06739	CBL, CPU ETHERNET TO AUX I/O PCA								
	ATX-	CPU PCA	067240000	LAN	1	AUX I/O PCA	067300100	J2	1
	ATX+	CPU PCA	067240000	LAN	2	AUX I/O PCA	067300100	J2	2
	LED0	CPU PCA	067240000	LAN	3	AUX I/O PCA	067300100	J2	3
	ARX+	CPU PCA	067240000	LAN	4	AUX I/O PCA	067300100	J2	4
	ARX-	CPU PCA	067240000	LAN	5	AUX I/O PCA	067300100	J2	5
	LED0+	CPU PCA	067240000	LAN	6	AUX I/O PCA	067300100	J2	6
	LED1	CPU PCA	067240000	LAN	7	AUX I/O PCA	067300100	J2	7
	LED1+	CPU PCA	067240000	LAN	8	AUX I/O PCA	067300100	J2	8
06741	CBL, CPU USB TO LCD INTERFACE PCA								
	GND	CPU PCA	067240000	USB	8	LCD Interface PCA	066970000	JP9	
	LUSBD3+	CPU PCA	067240000	USB	6	LCD Interface PCA	066970000	JP9	
	LUSBD3-	CPU PCA	067240000	USB	4	LCD Interface PCA	066970000	JP9	
	VCC	CPU PCA	067240000	USB	2	LCD Interface PCA	066970000	JP9	
06746	CBL, MB TO 06154 CPU								
	GND	Motherboard	058021100	P12	2	Shield			
	RX0	Motherboard	058021100	P12	14	CPU PCA	067240000	COM1	1
	RTS0	Motherboard	058021100	P12	13	CPU PCA	067240000	COM1	8
	TX0	Motherboard	058021100	P12	12	CPU PCA	067240000	COM1	4
	CTS0	Motherboard	058021100	P12	11	CPU PCA	067240000	COM1	7
	RS-GND0	Motherboard	058021100	P12	10	CPU PCA	067240000	COM1	6
	RTS1	Motherboard	058021100	P12	8	CPU PCA	067240000	COM2	8
	CTS1/485-	Motherboard	058021100	P12	6	CPU PCA	067240000	COM2	7
	RX1	Motherboard	058021100	P12	9	CPU PCA	067240000	COM2	1
	TX1/485+	Motherboard	058021100	P12	7	CPU PCA	067240000	COM2	4
	RS-GND1	Motherboard	058021100	P12	5	CPU PCA	067240000	COM2	6
	RX1	Motherboard	058021100	P12	9	CPU PCA	067240000	485	1
	TX1/485+	Motherboard	058021100	P12	7	CPU PCA	067240000	485	2
	RS-GND1	Motherboard	058021100	P12	5	CPU PCA	067240000	485	3
06809	CBL ASSY, DC POWER TO MOTHERBOARD								
	DGND	Relay PCA	041350000	J14	1	Motherboard	058021100	J15	1
	+5V	Relay PCA	041350000	J14	2	Motherboard	058021100	J15	2
	AGND	Relay PCA	041350000	J14	3	Motherboard	058021100	J15	3
	+15V	Relay PCA	041350000	J14	4	Motherboard	058021100	J15	4
	AGND	Relay PCA	041350000	J14	5	Motherboard	058021100	J15	5
	-15V	Relay PCA	041350000	J14	6	Motherboard	058021100	J15	6
	+12V RET	Relay PCA	041350000	J14	7	Motherboard	058021100	J15	7
	+12V	Relay PCA	041350000	J14	8	Motherboard	058021100	J15	8
	Chassis Gnd	Relay PCA	041350000	J14	10	Motherboard	058021100	J15	9
06811	CBL ASSY, BENCH HEATER								
	Wheel Heater	Relay PCA	041350000	P3	1	Wheel Heater	055010000	P1	1
	AC Return	Relay PCA	041350000	P3	4	Wheel Heater	055010000	P1	2
	Bench Htr, 115V	Relay PCA	041350000	P3	2	Bench Htr	037250000	P1	1
	Bench Htr, 230V	Relay PCA	041350000	P3	3	Bench Htr	037250000	P1	2
	AC Return	Relay PCA	041350000	P3	4	Bench Htr	037250000	P1	3
	Chassis Gnd	Relay PCA	041350000	P3	5				
06815	CBL ASSY, AC POWER								
	AC Line	Power Entry	CN0000073		L	Power Switch	SW0000025		L
	AC Neutral	Power Entry	CN0000073		N	Power Switch	SW0000025		N
	Power Grnd	Power Entry	CN0000073			Shield			
	Power Grnd	Power Entry	CN0000073			Chassis			
	AC Line Switched	Power Switch	SW0000025		L	PS2 (+12)	068020000	SK2	1
	AC Neu Switched	Power Switch	SW0000025		N	PS2 (+12)	068020000	SK2	3
	Power Grnd	Power Entry	CN0000073			PS2 (+12)	068020000	SK2	2
	AC Line Switched	Power Switch	SW0000025		L	PS1 (+5, ±15)	068010000	SK2	1
	AC Neu Switched	Power Switch	SW0000025		N	PS1 (+5, ±15)	068010000	SK2	3
	Power Grnd	Power Entry	CN0000073			PS1 (+5, ±15)	068010000	SK2	2
	AC Line Switched	Power Switch	SW0000025		L	Relay	041350000	J1	1
	AC Neu Switched	Power Switch	SW0000025		N	Relay	041350000	J1	3
	Power Grnd	Power Entry	CN0000073			Relay	041350000	J1	2

Interconnect List, T300/M T360/M

(Reference 0691201B DCN5947)

Cable PN	Signal	FROM				TO			
		Assembly	PN	J/P	Pin	Assembly	PN	J/P	Pin
06816	CBL ASSY, DC POWER								
	+15	PS1	068010000	SK1	6	Relay PCA	041350000	J13	4
	+5	PS1	068010000	SK1	1	Relay PCA	041350000	J13	3
	DGND	PS1	068010000	SK1	3	Relay PCA	041350000	J13	1
	AGND	PS1	068010000	SK1	4	Relay PCA	041350000	J13	5
	-15	PS1	068010000	SK1	5	Relay PCA	041350000	J13	6
	+12	PS2	068020000	SK1	1	Relay PCA	041350000	J13	8
	+12 RET	PS2	068020000	SK1	3	Relay PCA	041350000	J13	7
06817	CBL, RELAY BD TO SOURCE								
	IR Source Drv	Relay PCA	041350000	J16	1	IR Source	009550500	P1	1
	IR Source Drv	Relay PCA	041350000	J16	2	IR Source	009550500	P1	2
06917	CBL, DC POWER & SIGNAL DISTRIBUTION								
	+5V	LCD Interface PCA	066970000	J14	1	Relay PCA	041350000	J12	2
	DGND	LCD Interface PCA	066970000	J14	2	Relay PCA	041350000	J11	1
	+5V	LCD Interface PCA	066970000	J14	3	Relay PCA	041350000	J11	2
	SDA	LCD Interface PCA	066970000	J14	5	Relay PCA	041350000	J5	2
	SCL	LCD Interface PCA	066970000	J14	6	Relay PCA	041350000	J5	1
	DGND	LCD Interface PCA	066970000	J14	8	Relay PCA	041350000	J12	1
	Shield	LCD Interface PCA	066970000	J14	10	Relay PCA	041350000	J5	5
	+12V Ret	Fan	040010000	P1	1	Relay PCA	041350000	J11	7
	+12V	Fan	040010000	P1	2	Relay PCA	041350000	J11	8
	AGND	Flow Module	040030100	J1	3	Relay PCA	041350000	J11	3
	+15V	Flow Module	040030100	J1	6	Relay PCA	041350000	J11	4
	Cell Pressure	Flow Module	040030100	J1	4	Motherboard	058021100	J109	5
	Pump Vaccum	Flow Module	040030100	J1	2	Motherboard	058021100	J109	6
	Sample Flow	Flow Module	040030100	J1	5	Motherboard	058021100	J109	2
		Shield				Motherboard	058021100	J109	9
	Measure	Sync Demod	032960000	J3	1	Motherboard	058021100	J109	4
	PD Temp	Sync Demod	032960000	J3	2	Motherboard	058021100	J109	1
	Reference	Sync Demod	032960000	J3	5	Motherboard	058021100	J109	3
	AGND	Sync Demod	032960000	J3	6	Shield			
	Dark Switch	Sync Demod	032960000	J3	4	Motherboard	058021100	J108	16
	Sync Error	Sync Demod	032960000	J3	7	Motherboard	058021100	J108	4
	Etest	Sync Demod	032960000	J3	8	Motherboard	058021100	J108	8
06925	CBL ASSY, SYNC DEMOD, DC POWER								
	DGND	Relay PCA	041350000	J15	1	Sync Demod	032960000	J2	1
	+5V	Relay PCA	041350000	J15	2	Sync Demod	032960000	J2	2
	AGND	Relay PCA	041350000	J15	3	Sync Demod	032960000	J2	3
	+15V	Relay PCA	041350000	J15	4	Sync Demod	032960000	J2	4
	AGND	Relay PCA	041350000	J15	5	Sync Demod	032960000	J2	5
	-15V	Relay PCA	041350000	J15	6	Sync Demod	032960000	J2	6
	DGND	Relay PCA	041350000	J15	1	O2 Sensor	049210000	P1	5
	+5V	Relay PCA	041350000	J15	2	O2 Sensor	049210000	P1	6
	+12V ret	Relay PCA	041350000	J15	7	CO2 Sensor			GND
	+12V	Relay PCA	041350000	J15	8	CO2 Sensor			+L
	O2-	O2 Sensor		P1	9	Motherboard	058021100	P110	10
	O2+	O2 Sensor		P1	10	Motherboard	058021100	P110	4
		Shield				Motherboard	058021100	P110	7
	CO2-	CO2 Sensor			0	Motherboard	058021100	P110	8
	CO2+	CO2 Sensor			V	Motherboard	058021100	P110	2
06746	CBL, MOTHERBOARD TO CPU								
	RXD(0)	CPU PCA	067240000	COM1	1	Motherboard	058021100	J12	14
	RTS(0)	CPU PCA	067240000	COM1	8	Motherboard	058021100	J12	13
	TXD(0)	CPU PCA	067240000	COM1	4	Motherboard	058021100	J12	12
	CTS(0)	CPU PCA	067240000	COM1	7	Motherboard	058021100	J12	11
	GND(0)	CPU PCA	067240000	COM1	6	Motherboard	058021100	J12	10
	RXD(1)	CPU PCA	067240000	COM2	1	Motherboard	058021100	J12	9
	RTS(1)	CPU PCA	067240000	COM2	8	Motherboard	058021100	J12	8
	TXD(1)	CPU PCA	067240000	COM2	4	Motherboard	058021100	J12	7
	CTS(1)	CPU PCA	067240000	COM2	7	Motherboard	058021100	J12	6
	GND(1)	CPU PCA	067240000	COM2	6	Motherboard	058021100	J12	5
	485+	CPU PCA	067240000	CN5	1	Motherboard	058021100	J12	9
	485-	CPU PCA	067240000	CN5	2	Motherboard	058021100	J12	7
	GND	CPU PCA	067240000	CN5	3	Motherboard	058021100	J12	5
	Shield					Motherboard	058021100	J12	2
WR256	CBL, TRANSMITTER TO LCD INTERFACE PCA								
		LCD Interface PCA	066970000	J15		Transmitter PCA	068810000	J1	

This page intentionally left blank.

REVISIONS				
REV	DESCRIPTION	DATE	DCN	APPROVED
A	INITIAL RELEASE	9/3/10	5833	KV
B	ADDED 360 FAMILY	12/30/10	5947	KV

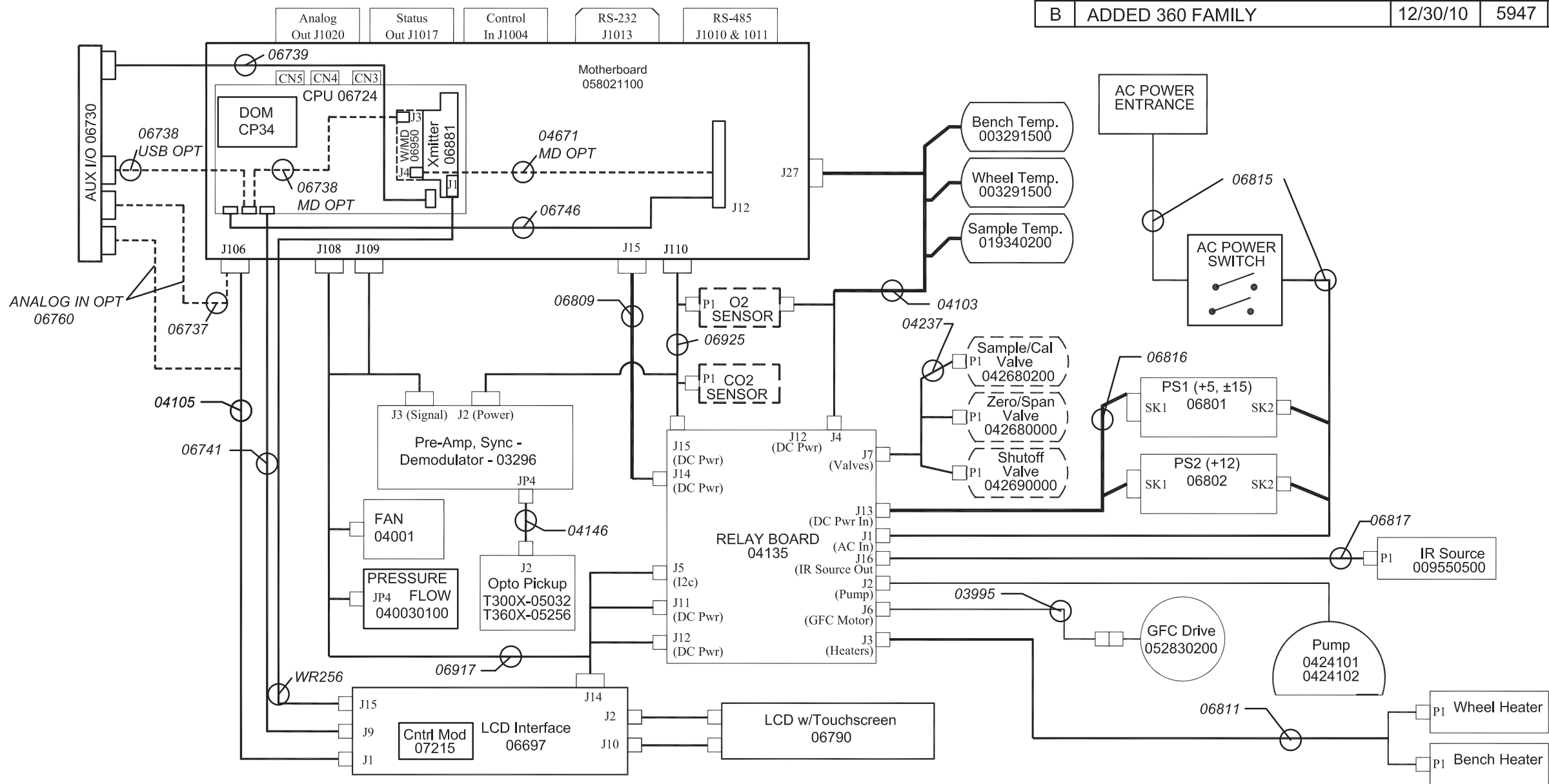

KEY:
 1. All part numbers in *Italic* identify cables that are referred to in the accompanying document 069120100.
 2. All items in Dashed boxes are optional.

PRINTED DOCUMENTS ARE UNCONTROLLED

The information hereon is the property of API and is submitted in strictest confidence for reference only. Unauthorized use by anyone for any other purposes is prohibited. This document or an information contained in it may not be duplicated without proper authorization.		UNLESS OTHERWISE SPECIFIED DIMENSIONS ARE IN INCHES TOLERANCES ARE: FRACTIONS DECIMALS ANGULAR $\pm 1/32$ $\pm .01[0.76]$ $\pm 0^\circ 30'$ DO NOT SCALE DRAWING		CONTRACT: NA		TELEDYNE <i>Advanced Pollution Instrumentation</i> A Teledyne Technologies Company					
		TREATMENT NA		APPROVALS DRAWN: KV CHECK: KV CCB:		DATE 4/10		TITLE INTERCONNECT DRAWING T300/M & T360/M			
FINISH 		SIMILAR TO 		ISSUED		SIZE B		CAGE CODE NO. DWG. NO. 1JZF4 06912		REV B	
THIRD ANGLE PROJECTION						SCALE DNS		FILE 06912		SHEET 1 OF 1	

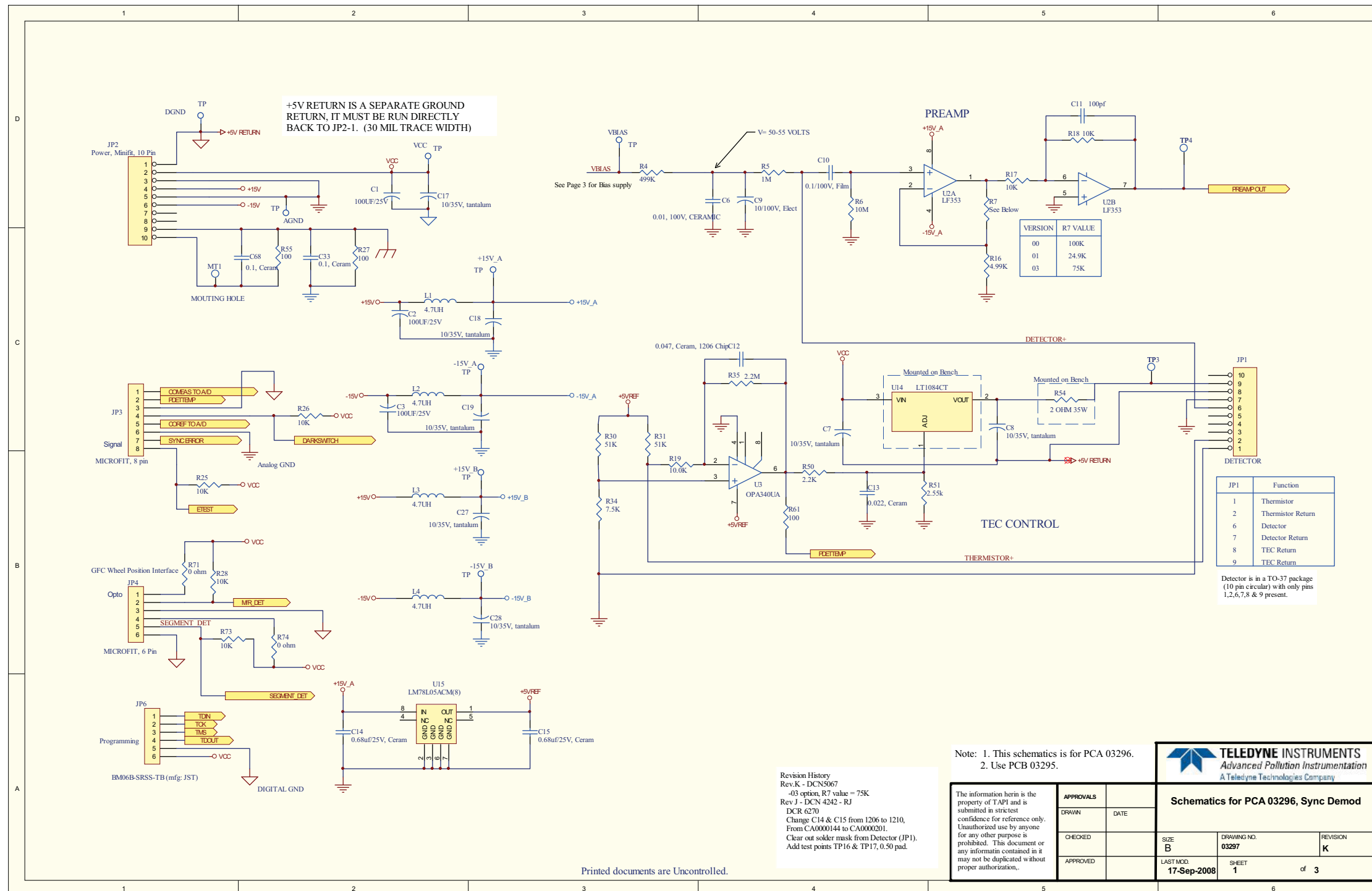

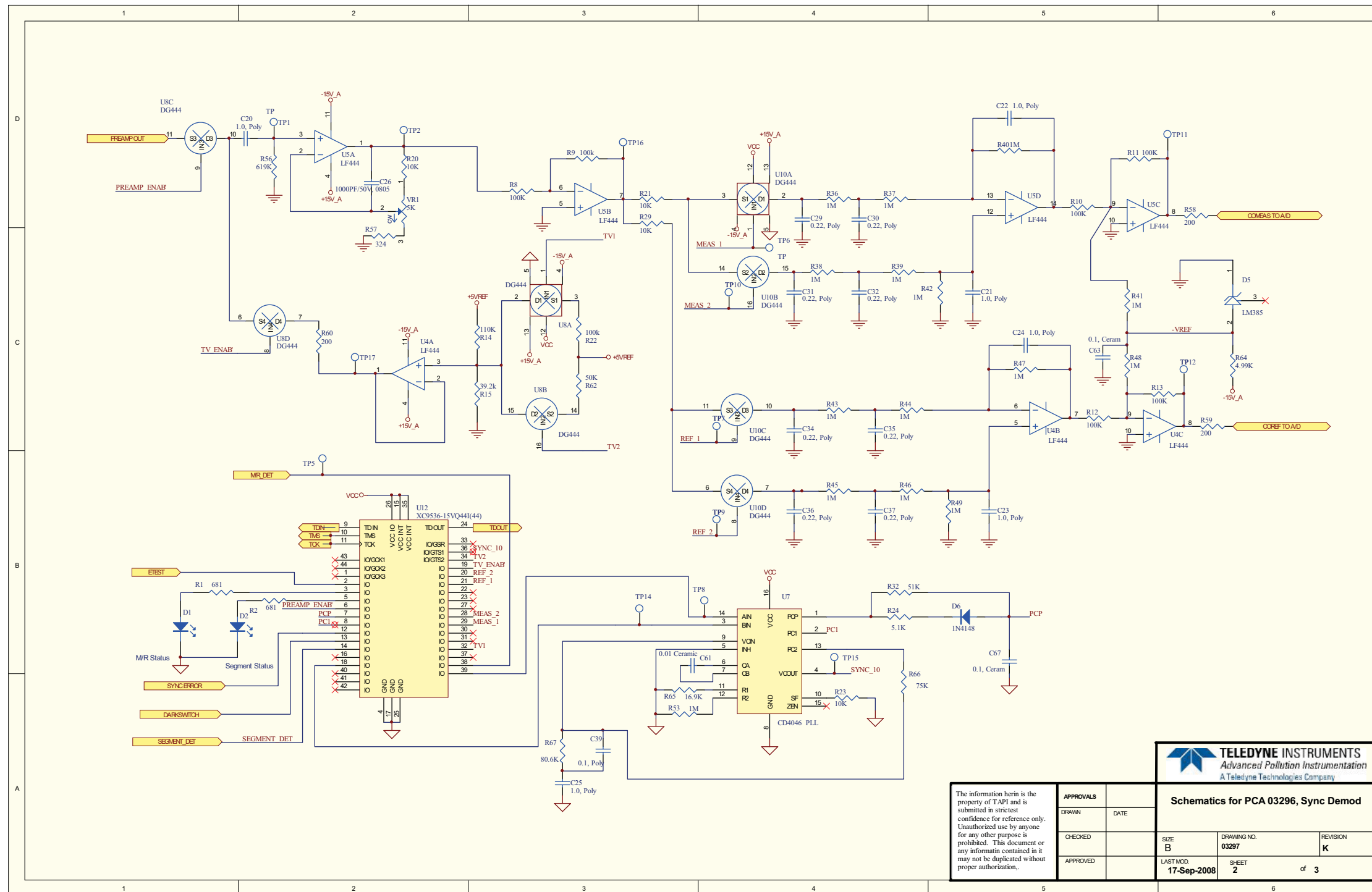

The information herein is the property of TAPI and is submitted in strictest confidence for reference only. Unauthorized use by anyone for any other purpose is prohibited. This document or any information contained in it may not be duplicated without proper authorization.

APPROVALS	DATE
DRAWN	
CHECKED	
APPROVED	



Schematics for PCA 03296, Sync Demod		
SIZE B	DRAWING NO. 03297	REVISION K
LAST MOD. 17-Sep-2008	SHEET 2	of 3

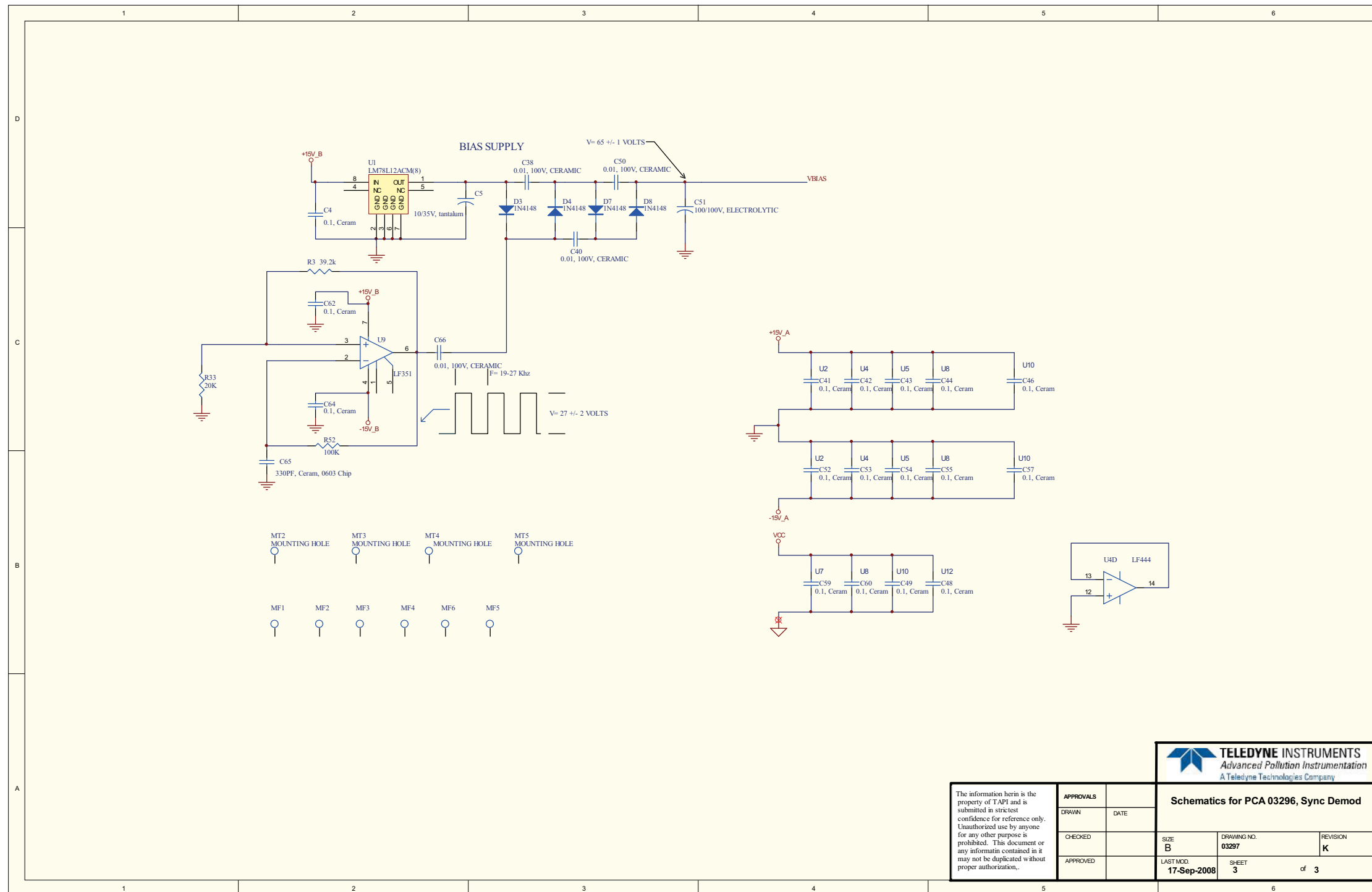

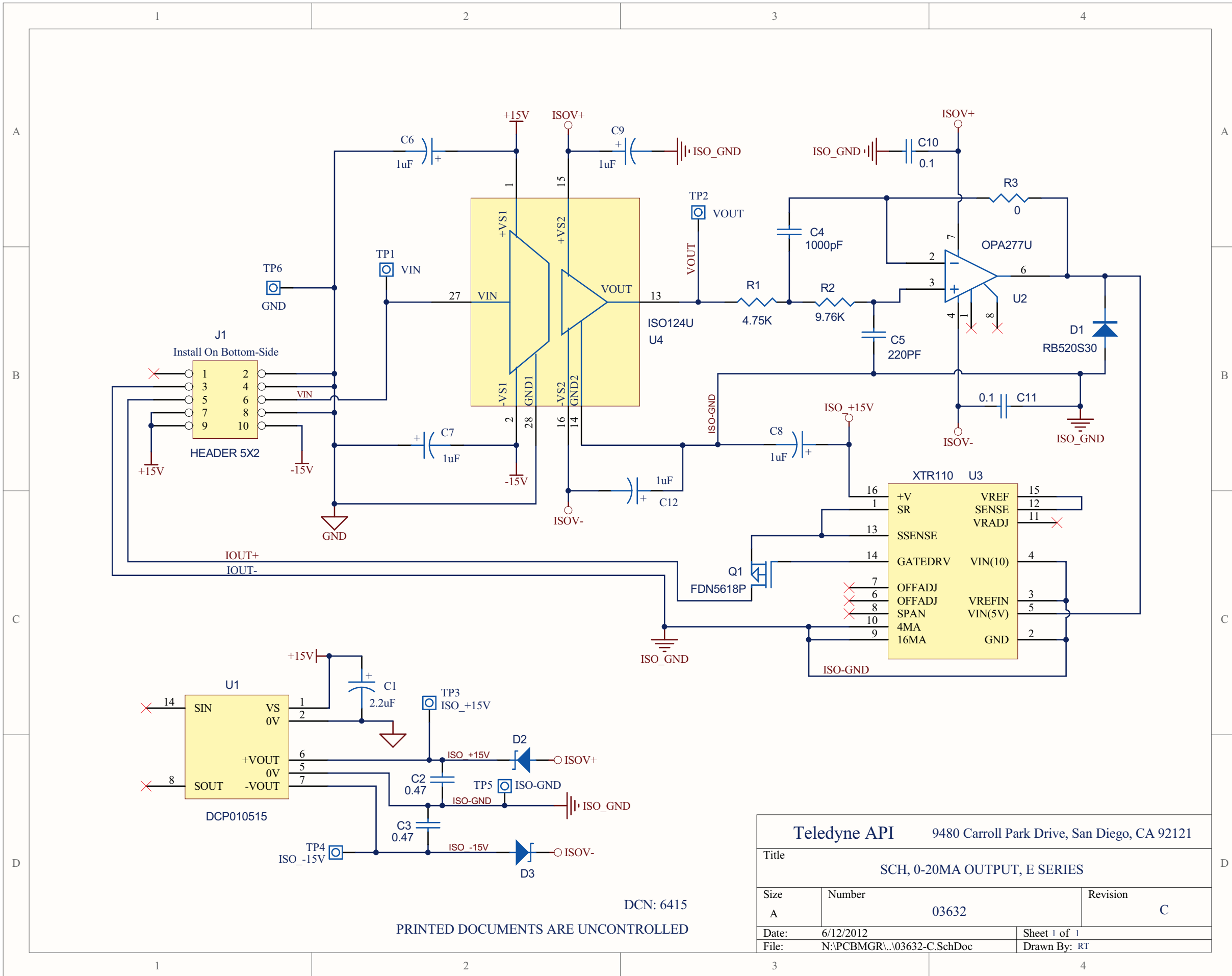

DCN: 6415

PRINTED DOCUMENTS ARE UNCONTROLLED

Teledyne API		9480 Carroll Park Drive, San Diego, CA 92121	
Title			
SCH, 0-20MA OUTPUT, E SERIES			
Size	Number	Revision	
A	03632	C	
Date:	6/12/2012	Sheet 1 of 1	
File:	N:\PCB\MGR\...\03632-C.SchDoc	Drawn By:	RT

Notes:

1. Install HW269 (#4x0.25" PCB Spacer) at each corner mounting hole on the solder side.
2. Install SN69 (#4-40 PEM nut) at S1, S2 & S3 on the solder side.
- ⚠ Install three socket pins on the circuit side of the board at S3 and apply solder on solder side ensuring socket pin hole is free of solder.
4. See Version Table for installation of S1, S2, & S3.
- ⚠ Securely fasten sensors (S1 & S2) to the PCB before soldering. Form the leads of the switch into a right angle and solder into the center four positions on the PCB. See Detail 'B'.
6. Use adjustable soldering station set to 250 C (480 F) when soldering sensors (S1 & S2). Do not solder sensor leads for more than 4 Seconds each.
- ⚠ Install flowmeter (S3) after soldering, Detail 'A', or Detail 'C'.

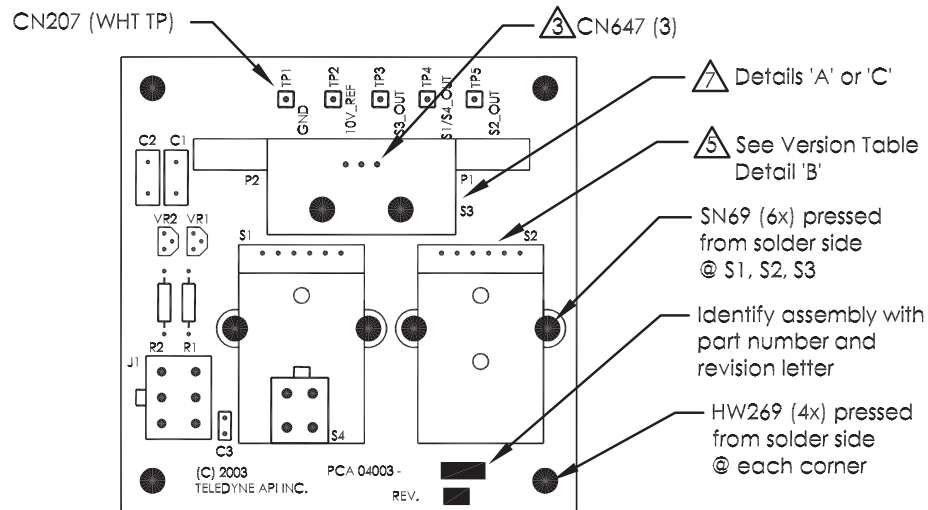
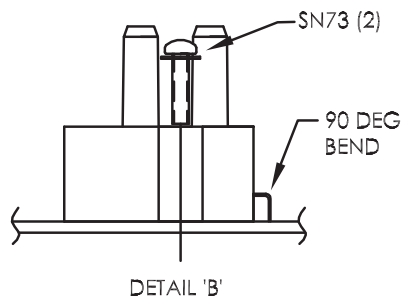
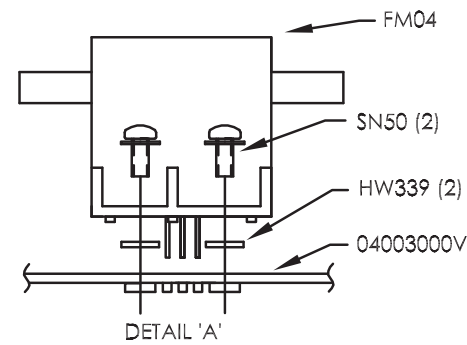

REVISIONS				
REV	DESCRIPTION	DATE	DCN	APPROVED
B	UPDATE FOR REV C PCB	10/12/05	3743	CB
C	ADDED 700E VERSIONS	11/1/05	3769	KV
D	CHG R1 & R2 FROM 1/4w TO 1/8w	11/22/05	3795	CB
E	ADDED NOTE 6	1/19/06	3845	KV
F	ADDED -10 & -11	4/29/06	3999	RH
G	REPLACED SW26 WITH SW59	11/22/06	4280	KV
H	ADDED DETAIL 'A'	6/9/07	4545	KV
J	ADDED DETAIL 'B' & SOCKET PINS	10/18/07	4711	KV
K	ADDED DETAIL 'C', REVISED TABLE	3/3/08	4826	KV
L	ADDED VERSION -12	8/18/08	5069	CB
M	SPEC MAX SOLDER TEMP AND TIME	11/13/09	5607	TW
N	REDREW DETAIL 'C'	1/20/10	5577	KV

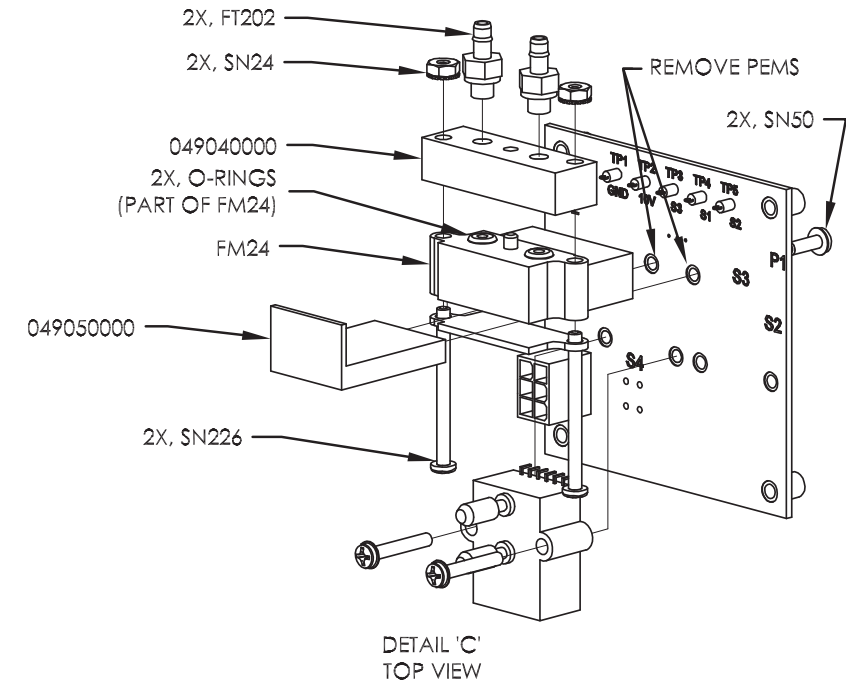

VERSION TABLE						
VERSION	S1	S2	S3	S4	VR1	USED ON
000V					IC234	
0100	SW59		FM04		IC234	100E, 300E, 300EM, 400E
0200	SW59				IC234	TMS 02 SHELF
0300		SW49		CN58	IC234	GFC7000E
0400	SW59	SW59			IC234	
0500	SW60	SW60			IC234	700E STD
0600		SW60			IC234	700E O3 OPT
0700	SW59	SW60	FM04		IC234	700E PHOTO OPT
0800	SW59	SW59	FM04		IC234	200E
0900	SW59		FM24		IC234	300EU, 320E, 320EU
1000				CN58	IC234	GFC7001E
1100			FM04		IC234	M108E
1200			FM04		IC315	M465

PRINTED DOCUMENTS ARE UNCONTROLLED.

The information hereon is the property of API and is submitted in strictest confidence for reference only. Unauthorized use by anyone for any other purposes is prohibited. This document or an information contained in it may not be duplicated without proper authorization.

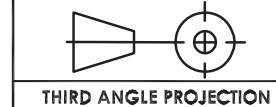

THIRD ANGLE PROJECTION

UNLESS OTHERWISE SPECIFIED DIMENSIONS ARE IN INCHES		
TOLERANCES ARE:	DECIMALS	ANGULAR
FRACTIONS	±.03(0.76)	±0° 30'
± 1/32	±.010(0.25)	
DO NOT SCALE DRAWING		
TREATMENT	NA	
FINISH	△	
SIMILAR TO		

CONTRACT: NA		TELEDYNE Advanced Pollution Instrumentation A Teledyne Technologies Company	
APPROVALS	DATE	TITLE	
KV	12/06	PCA, PRESSURE/FLOW E-SERIES	
CHECK		SIZE	REV
CCS		B	N
ISSUED		CAGE CODE NO.	DWG. NO.
		1JZF4	04003
		SCALE	SHEET
		NONE	1 OF 1

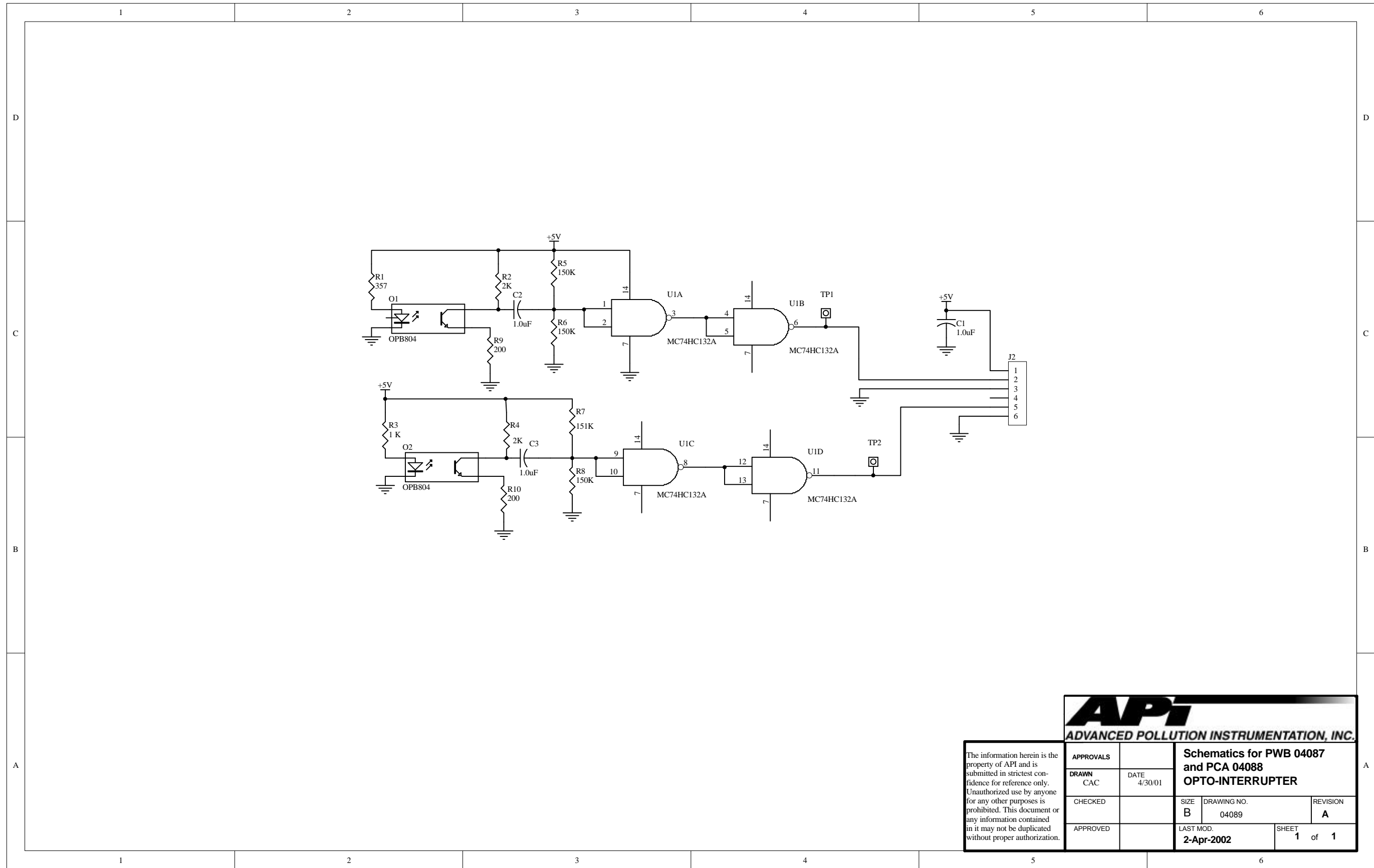

The information herein is the property of API and is submitted in strictest confidence for reference only. Unauthorized use by anyone for any other purposes is prohibited. This document or any information contained in it may not be duplicated without proper authorization.

APPROVALS		Schematics for PWB 04087 and PCA 04088	
DRAWN CAC	DATE 4/30/01	OPTO-INTERRUPTER	
CHECKED		SIZE B	DRAWING NO. 04089
APPROVED		REVISION A	LAST MOD. 2-Apr-2002
		SHEET 1 of 1	

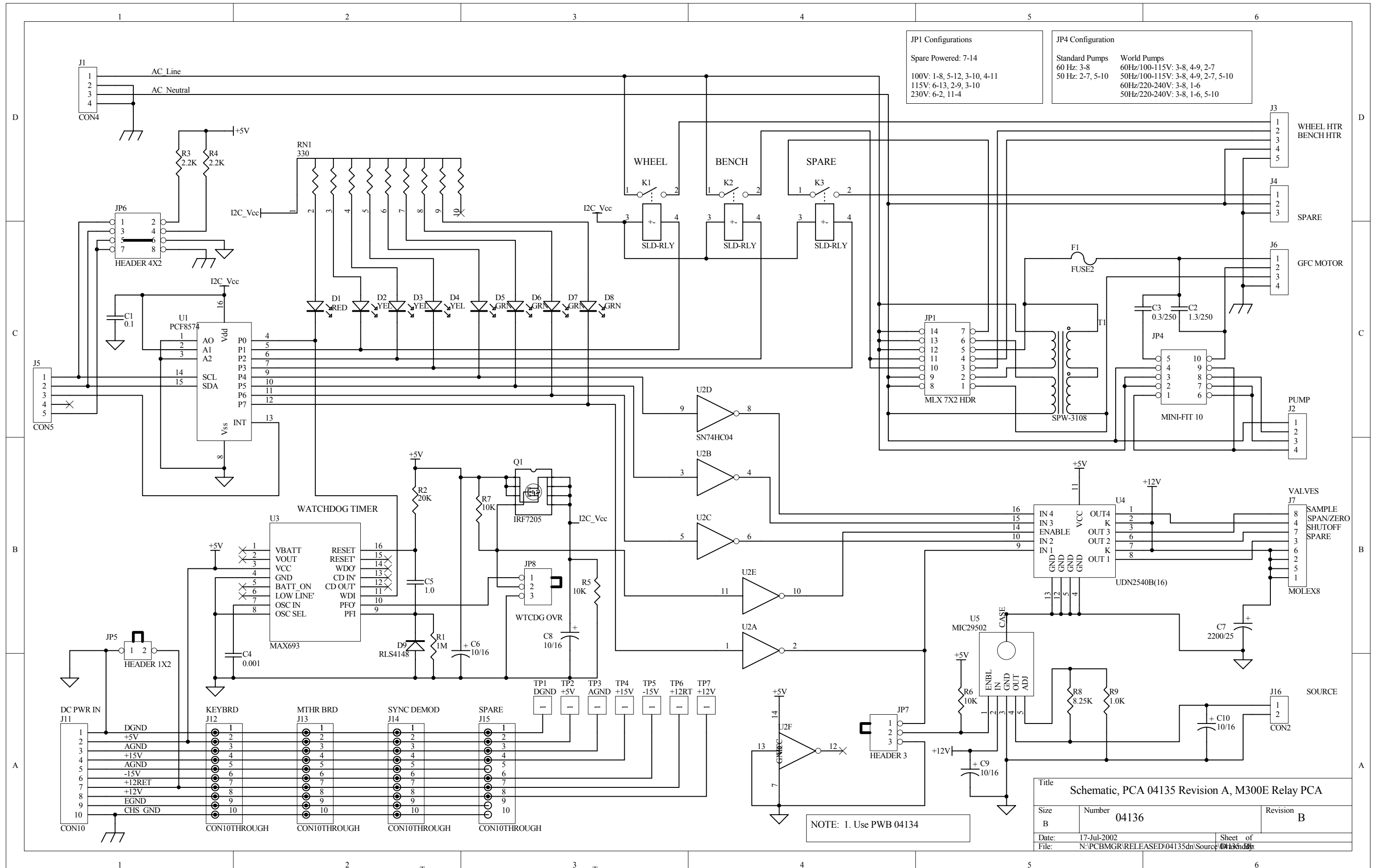

Title		
Schematic, PCA 04135 Revision A, M300E Relay PCA		
Size	Number	Revision
B	04136	B
Date:	17-Jul-2002	Sheet of
File:	N:\PCBMGR\RELEASED\04135dn\Source	of 1

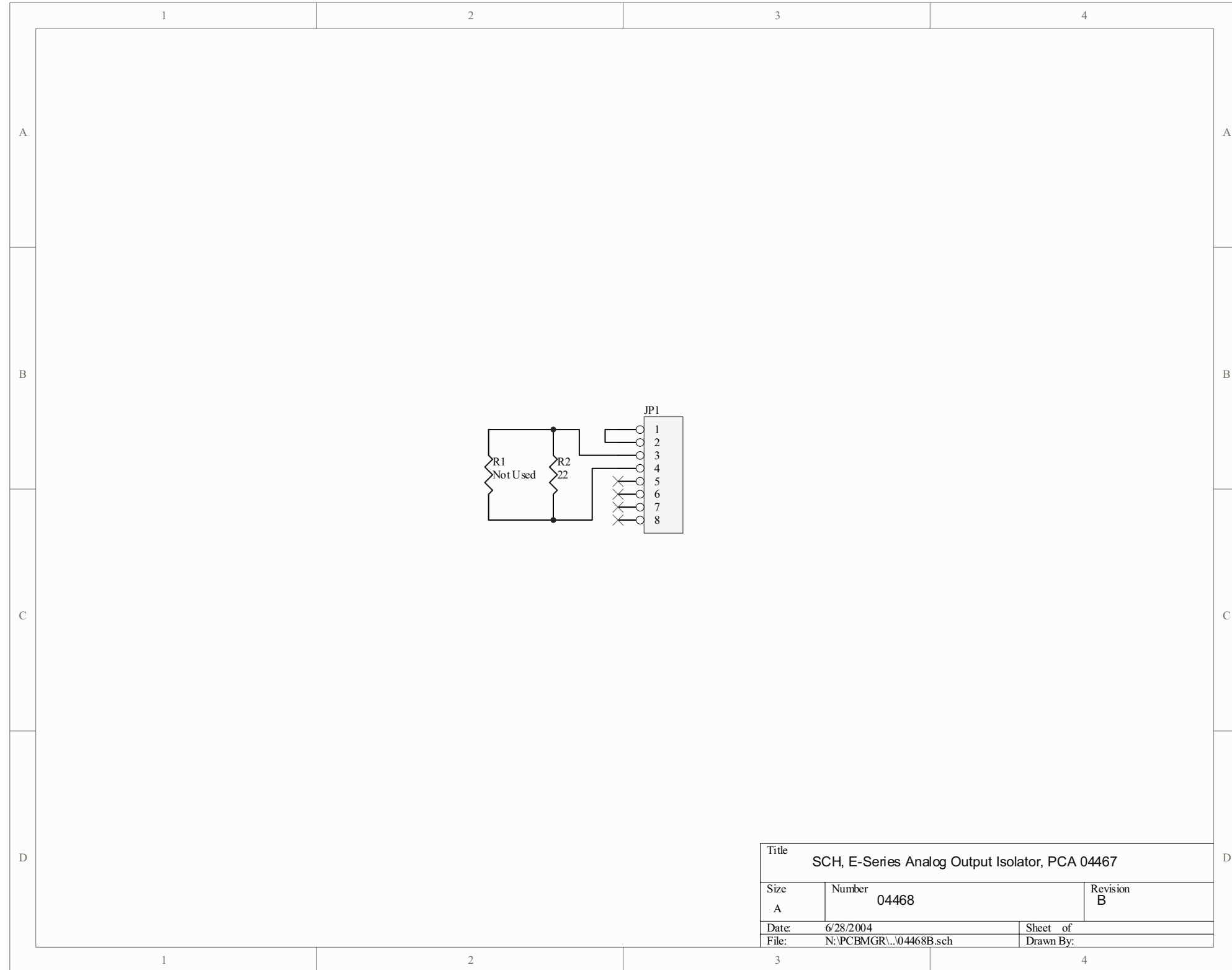

Title		
SCH, E-Series Analog Output Isolator, PCA 04467		
Size	Number	Revision
A	04468	B
Date:	6/28/2004	Sheet of
File:	N:\PCBMGR\..04468B.sch	Drawn By:

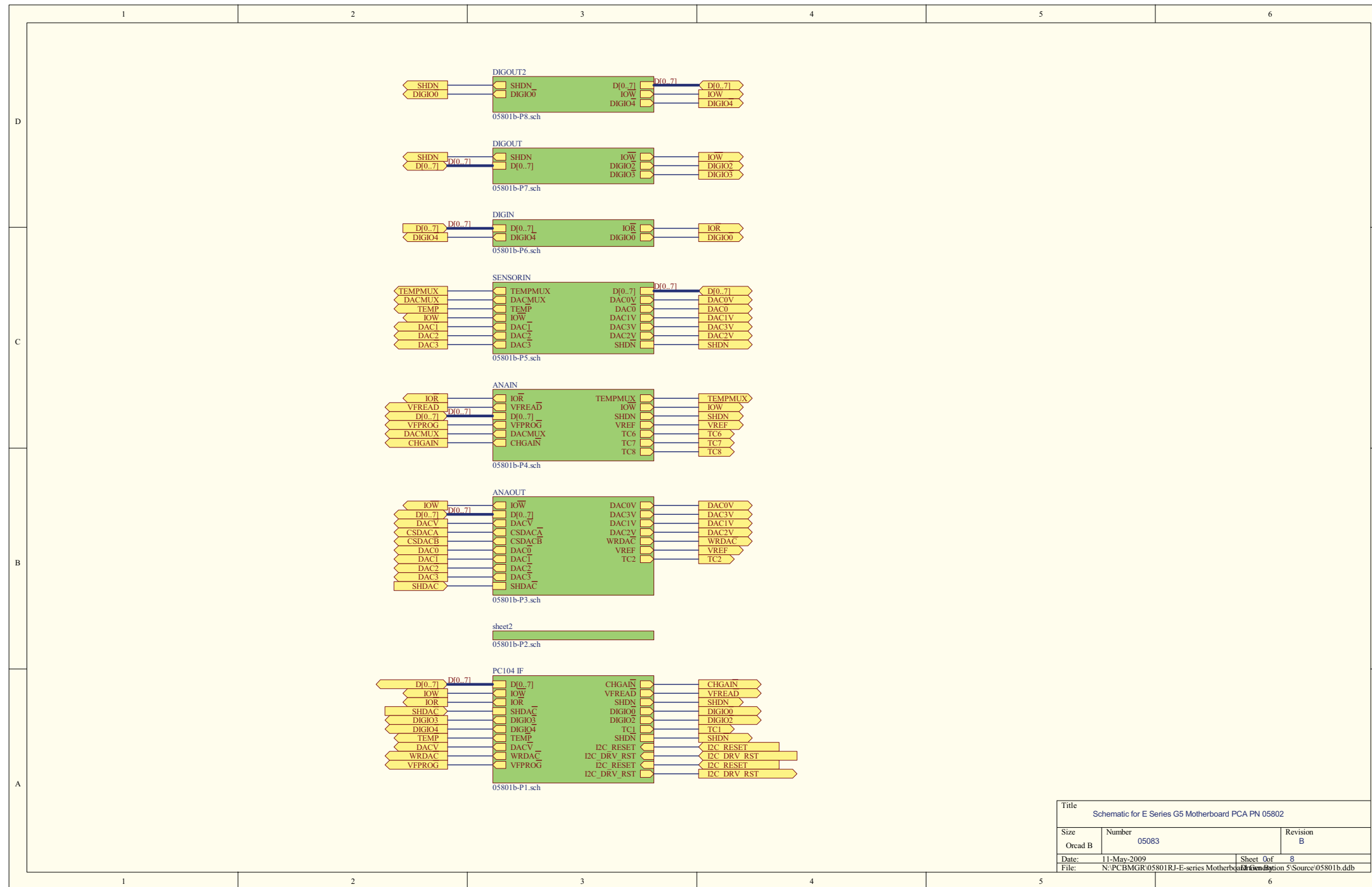

Title		
Schematic for E Series G5 Motherboard PCA PN 05802		
Size	Number	Revision
Orcaid B	05083	B
Date:	11-May-2009	Sheet Of 8
File:	N:\PCBMGR\05801RJ-E-series Motherboard\05801b.ddb	

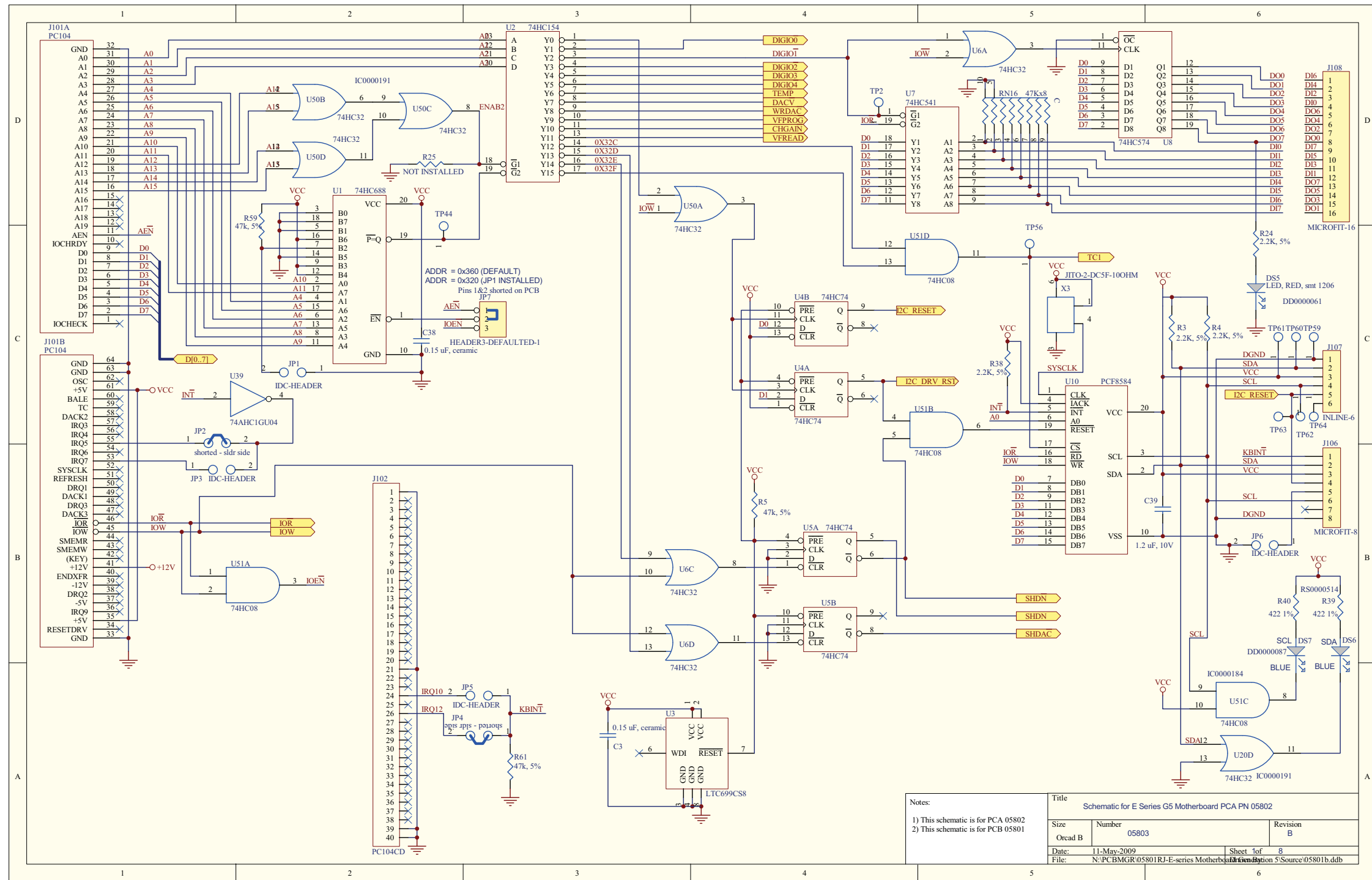

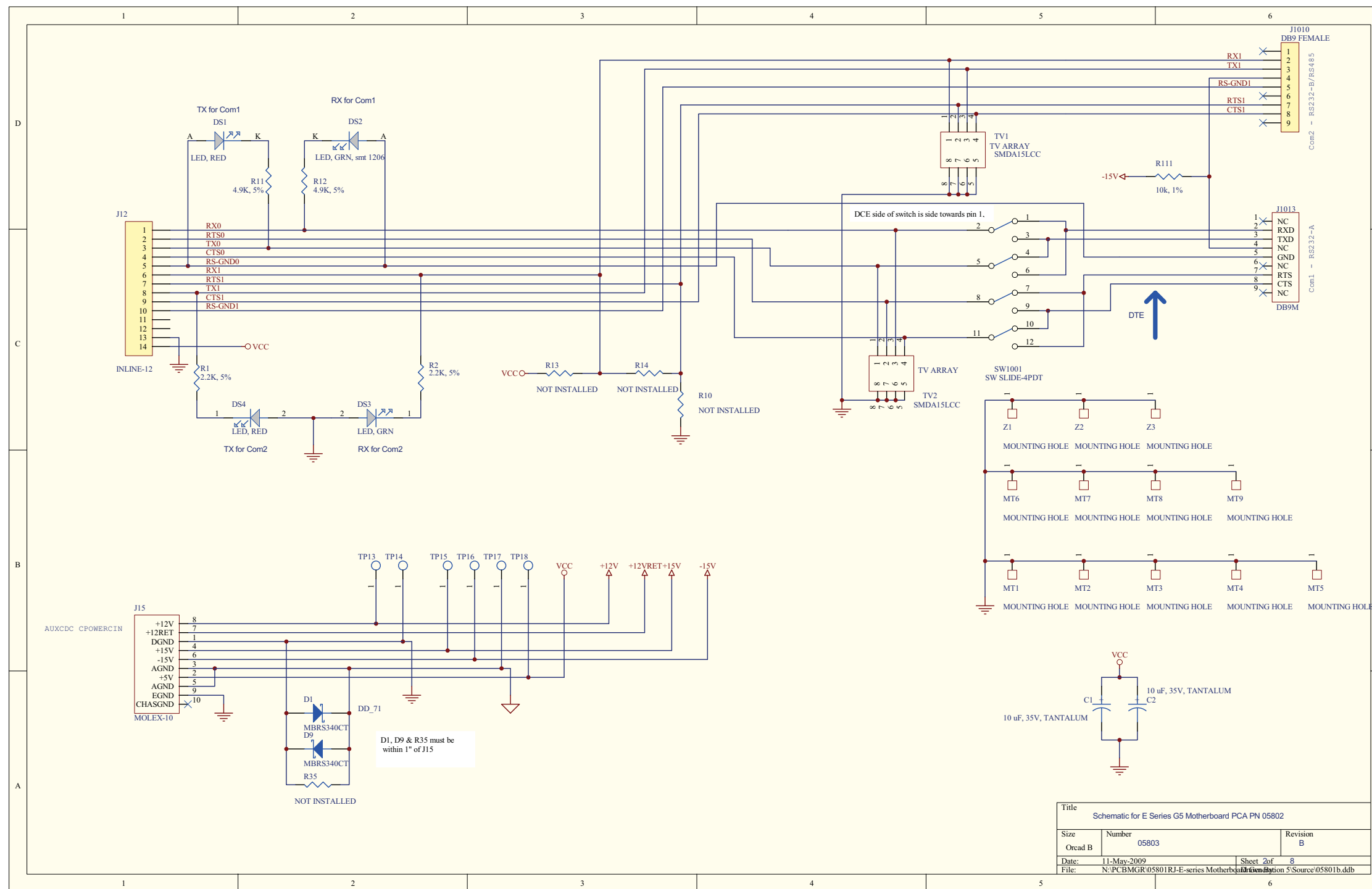

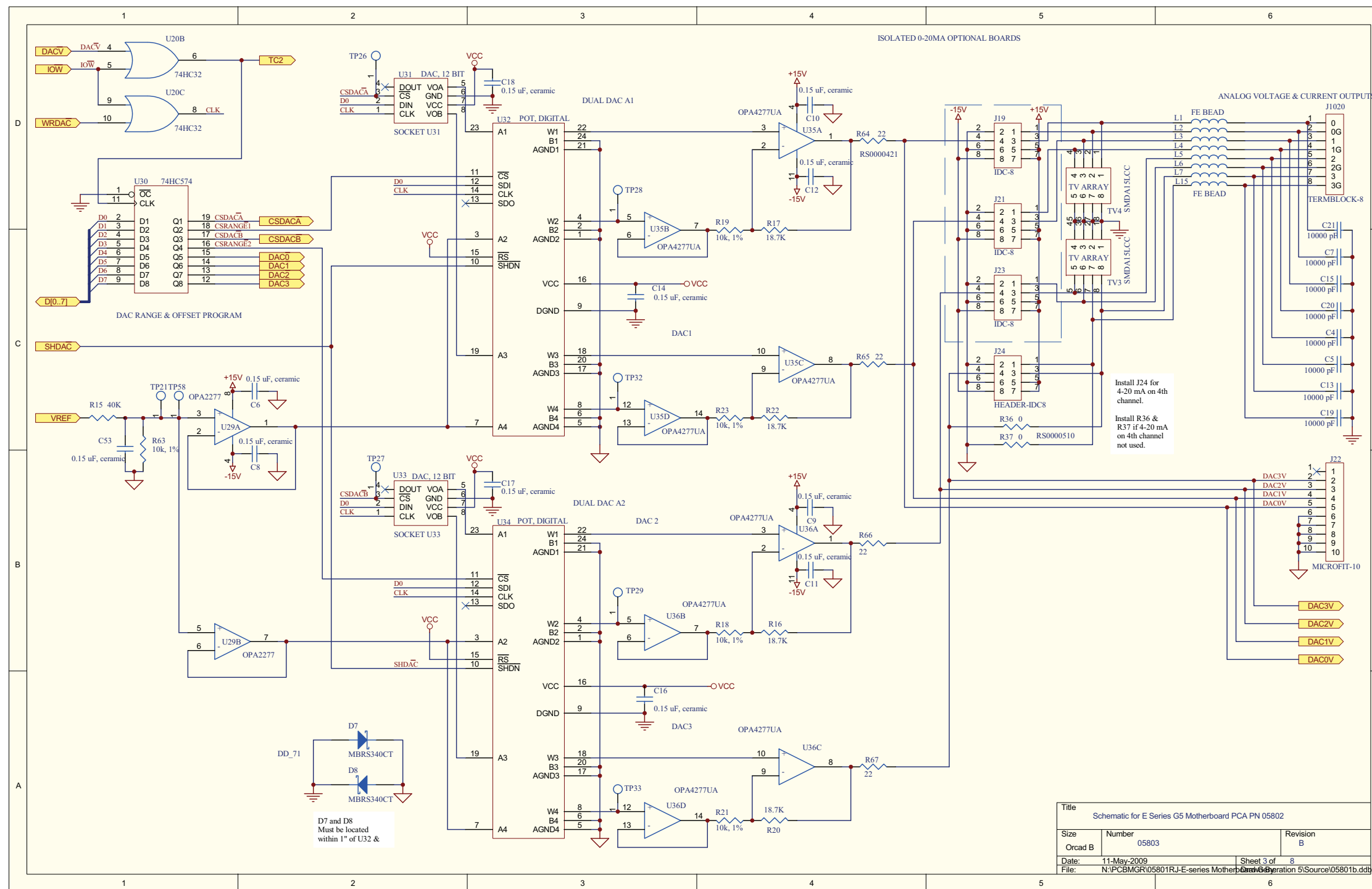

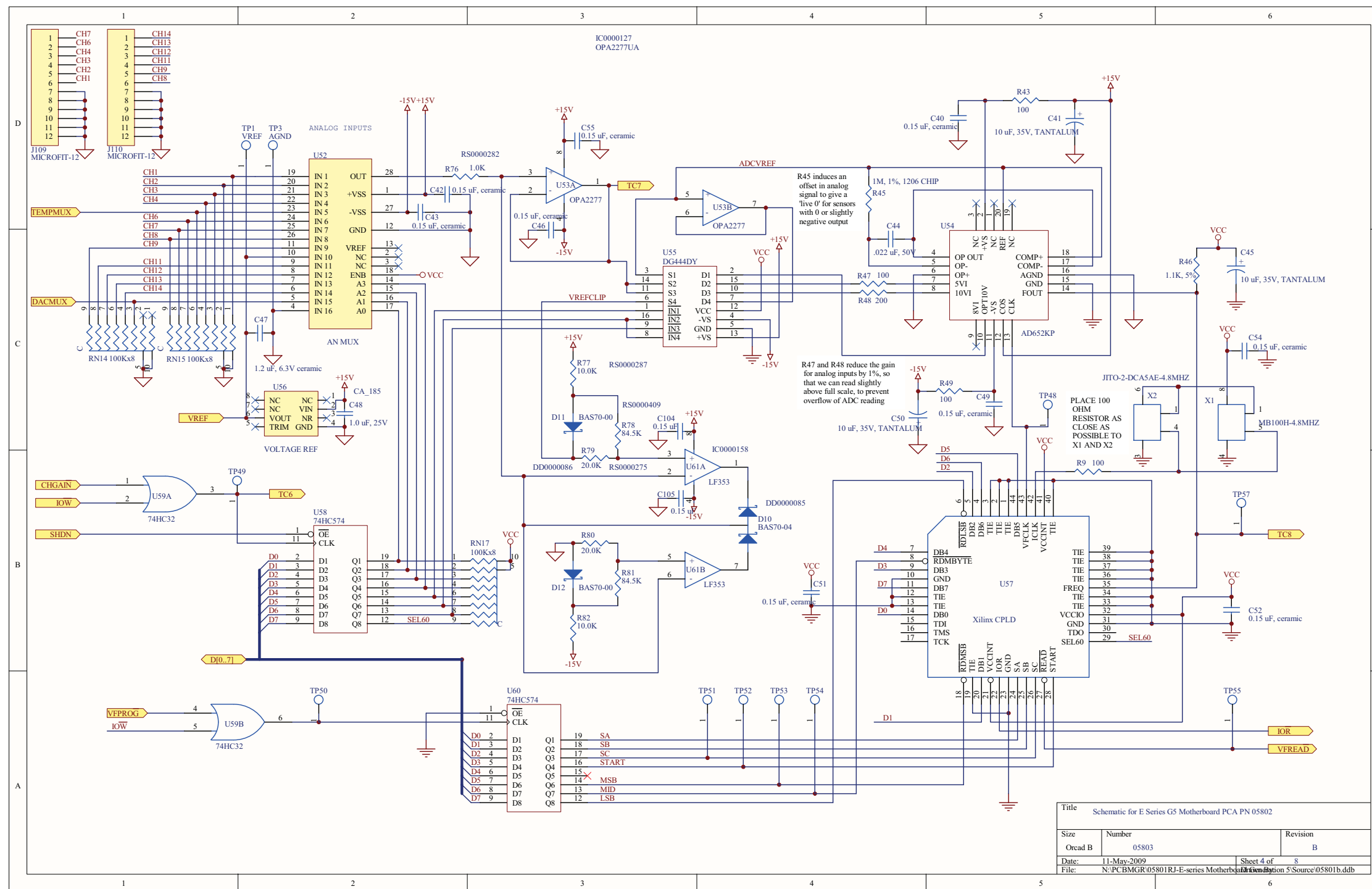

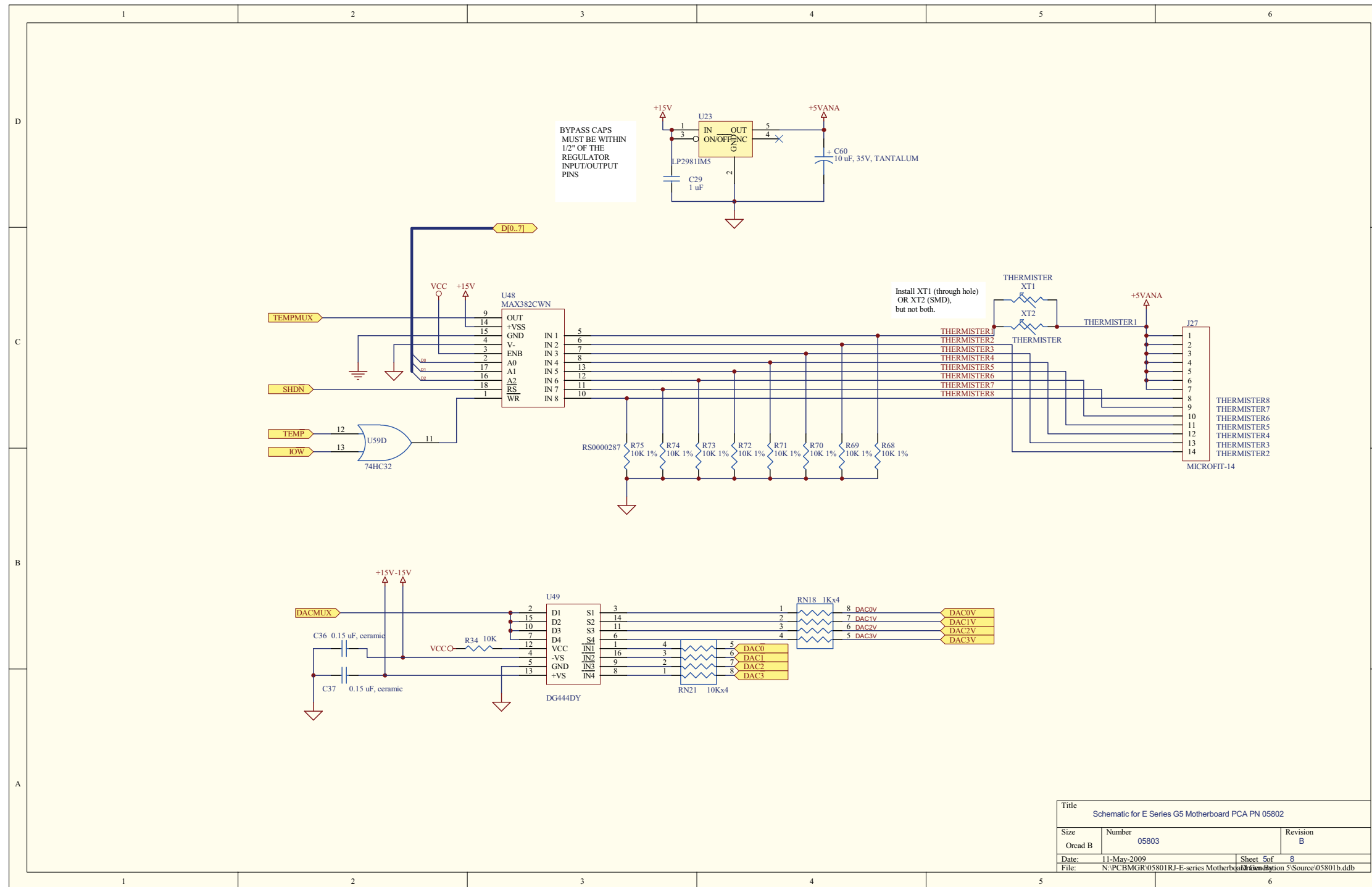

Title		
Schematic for E Series G5 Motherboard PCA PN 05802		
Size	Number	Revision
Orcad B	05803	B
Date:	11-May-2009	Sheet 5 of 8
File:	N:\PCBMGR\05801RJ-E-series Motherboard\05801b.ddb	

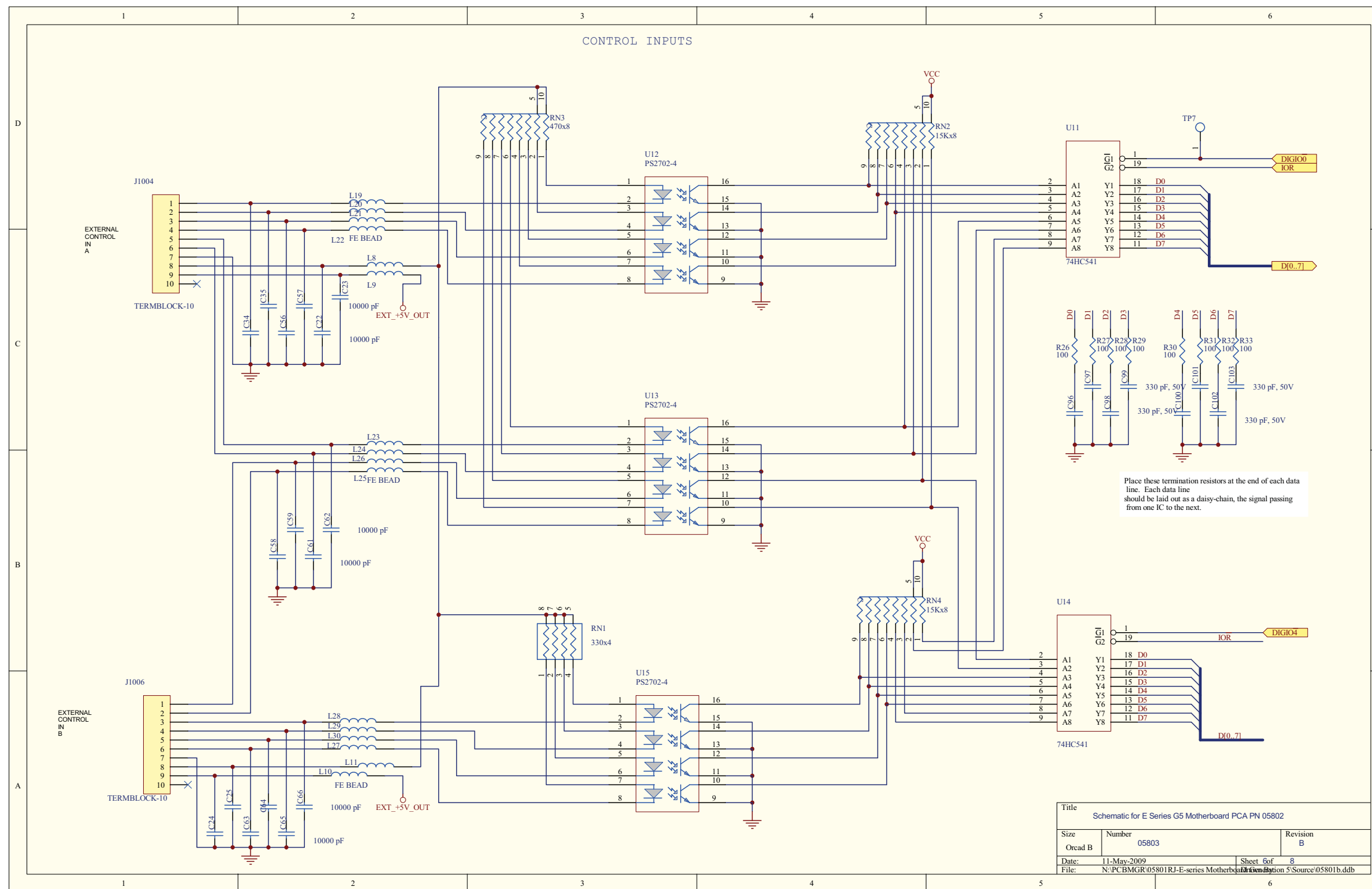

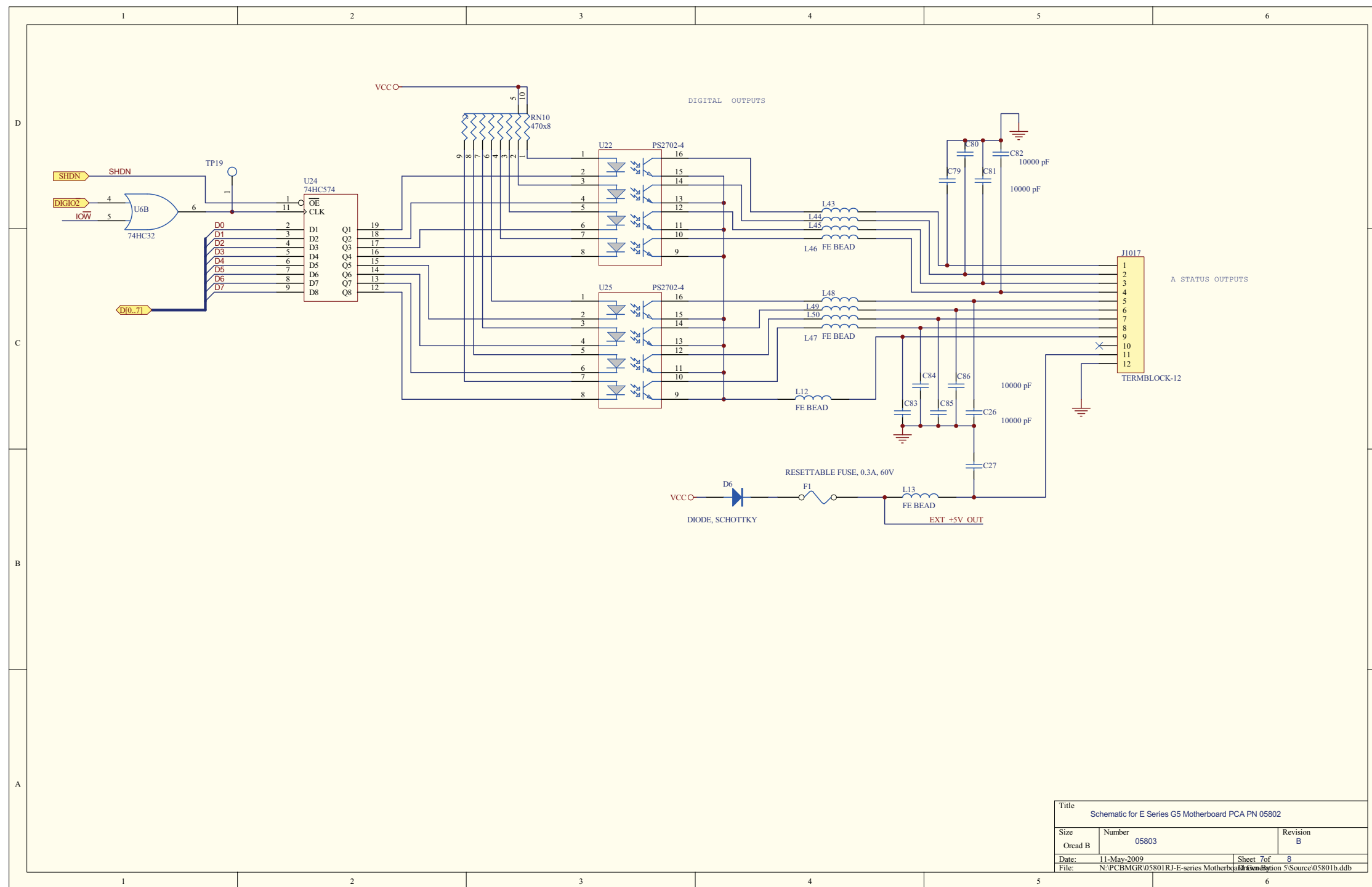

Title		
Schematic for E Series G5 Motherboard PCA PN 05802		
Size	Number	Revision
Orcad B	05803	B
Date:	11-May-2009	Sheet 7 of 8
File:	N:\PCBMGR\05801RJ-E-series Motherboard\16-Function 5\Source\05801b.ddb	

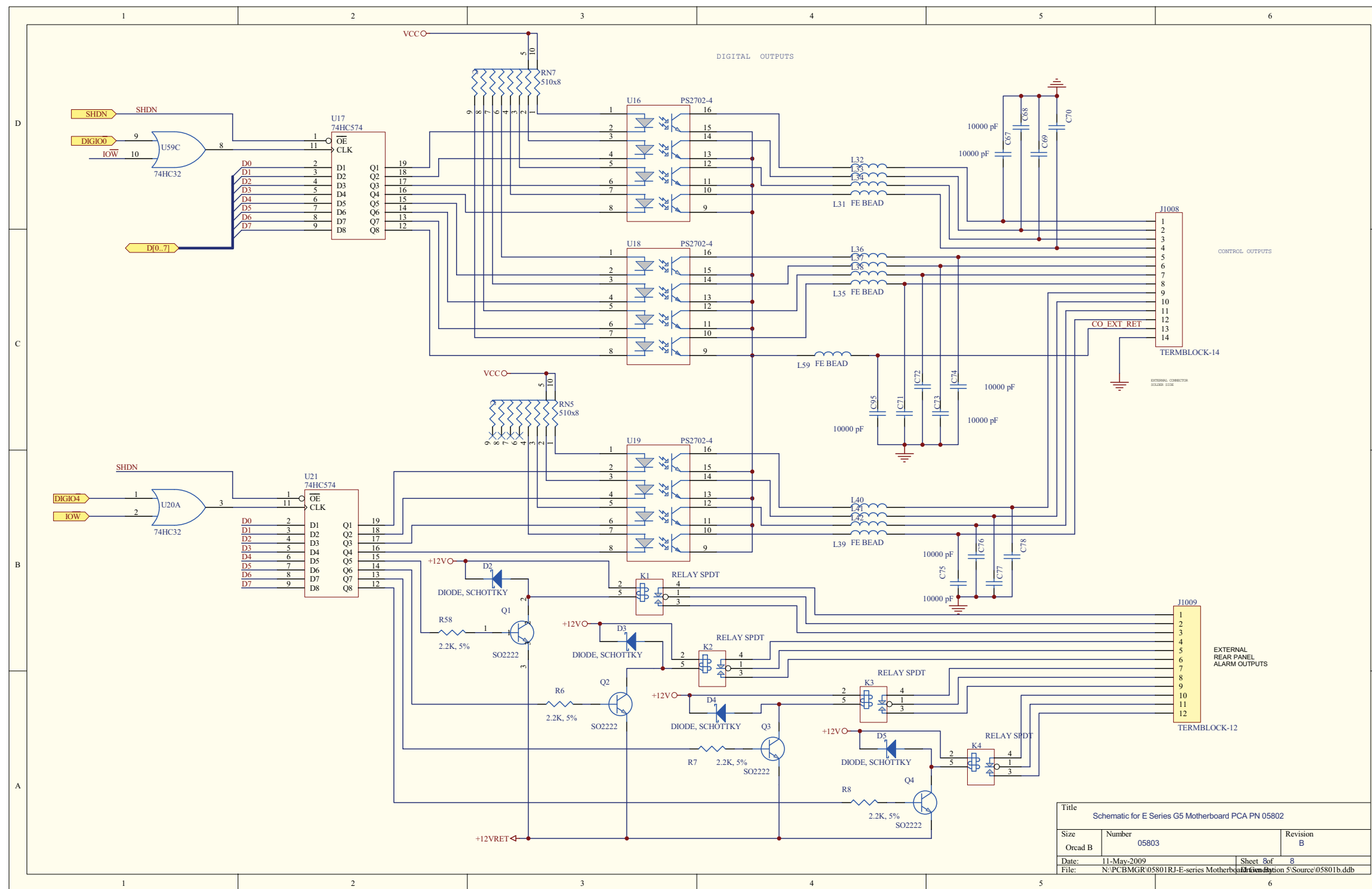

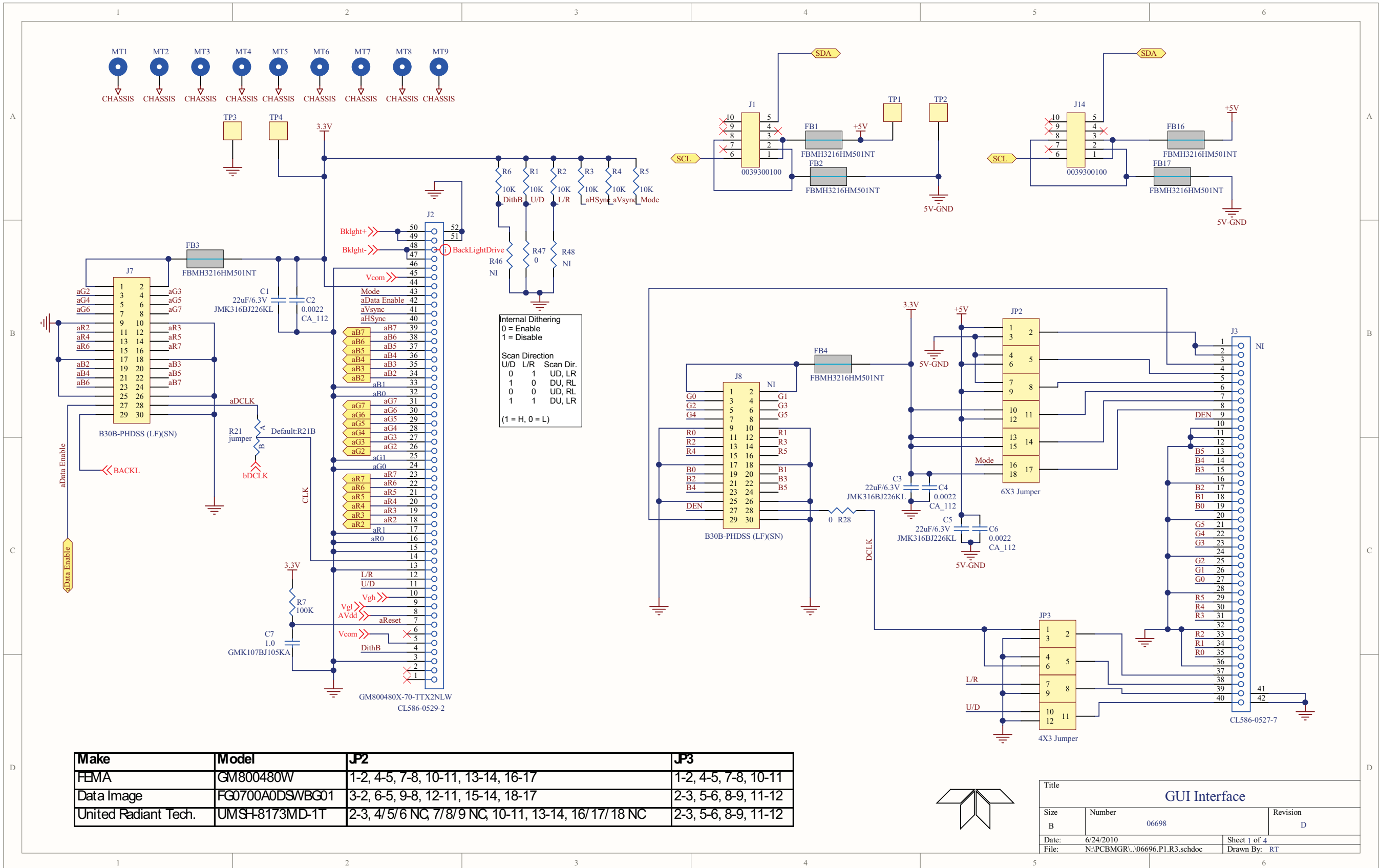

Make	Model	JP2	JP3
FEMA	GM800480W	1-2, 4-5, 7-8, 10-11, 13-14, 16-17	1-2, 4-5, 7-8, 10-11
Data Image	FG0700A0DSV/BG01	3-2, 6-5, 9-8, 12-11, 15-14, 18-17	2-3, 5-6, 8-9, 11-12
United Radiant Tech.	UMSH-8173MD-1T	2-3, 4/5/6 NC, 7/8/9 NC, 10-11, 13-14, 16/17/18 NC	2-3, 5-6, 8-9, 11-12

Title			GUI Interface		
Size	Number	Revision		D	
B	06698				
Date:	6/24/2010	Sheet 1 of 4		Drawn By: RT	
File:	N:\PCBMGRU\06696.P1.R3.schdoc				

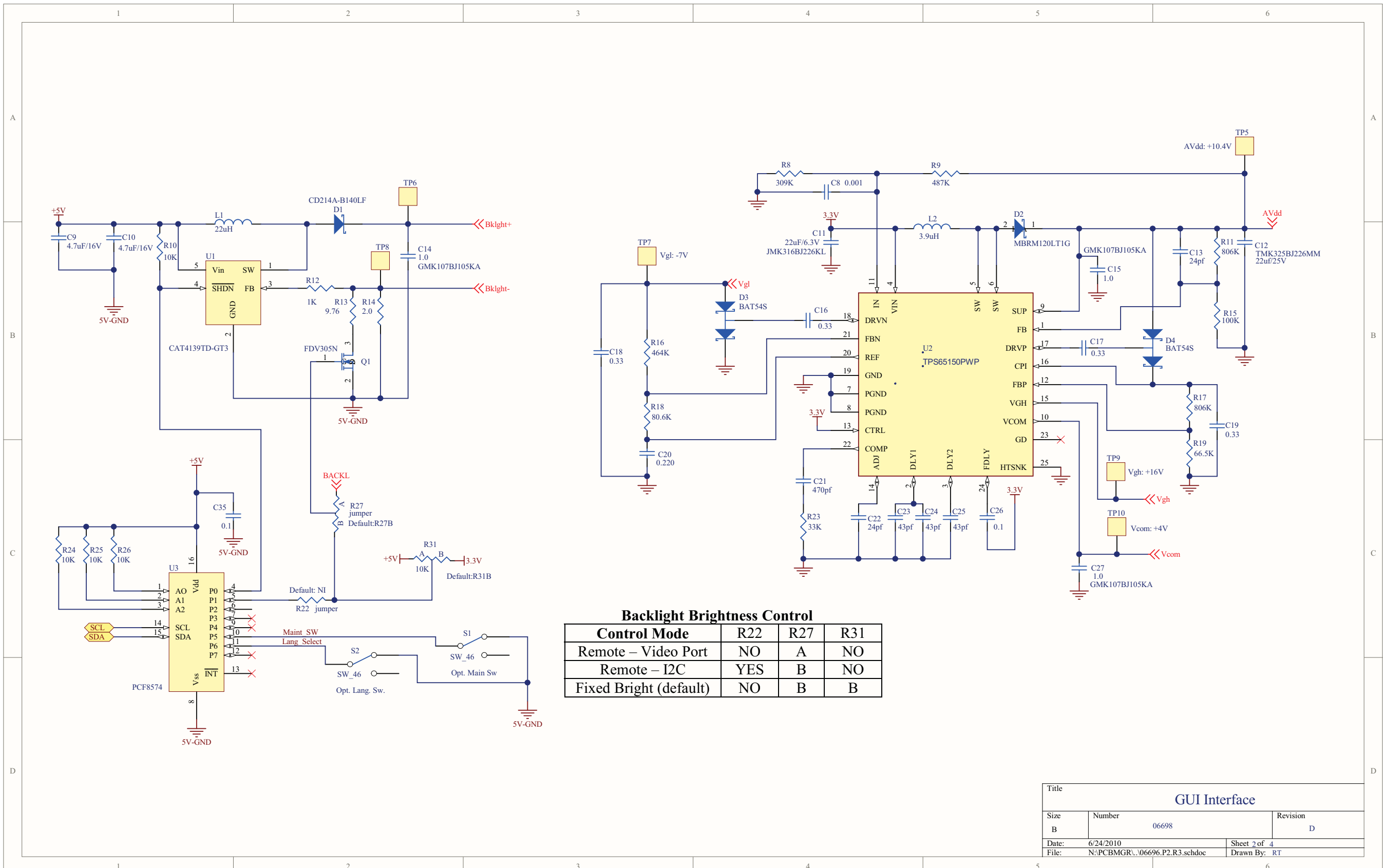

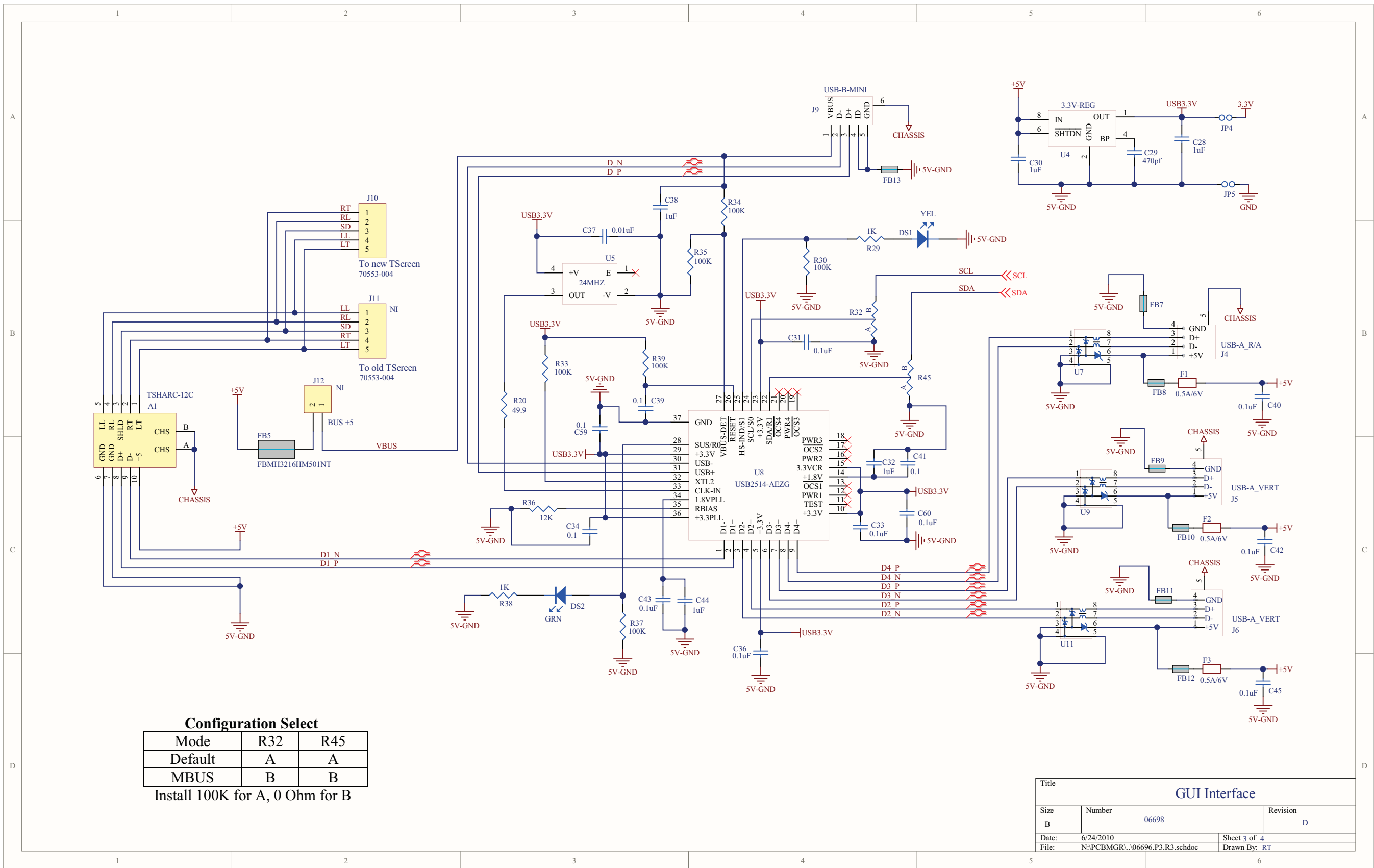

Configuration Select

Mode	R32	R45
Default	A	A
MBUS	B	B

Install 100K for A, 0 Ohm for B

Title		
GUI Interface		
Size	Number	Revision
B	06698	D
Date:	6/24/2010	Sheet 3 of 4
File:	N:\PCBMGRU\06696.P3.R3.schdoc	Drawn By: RT

TOUCH SCREEN INTERFACE CIRCUITRY (TBD)

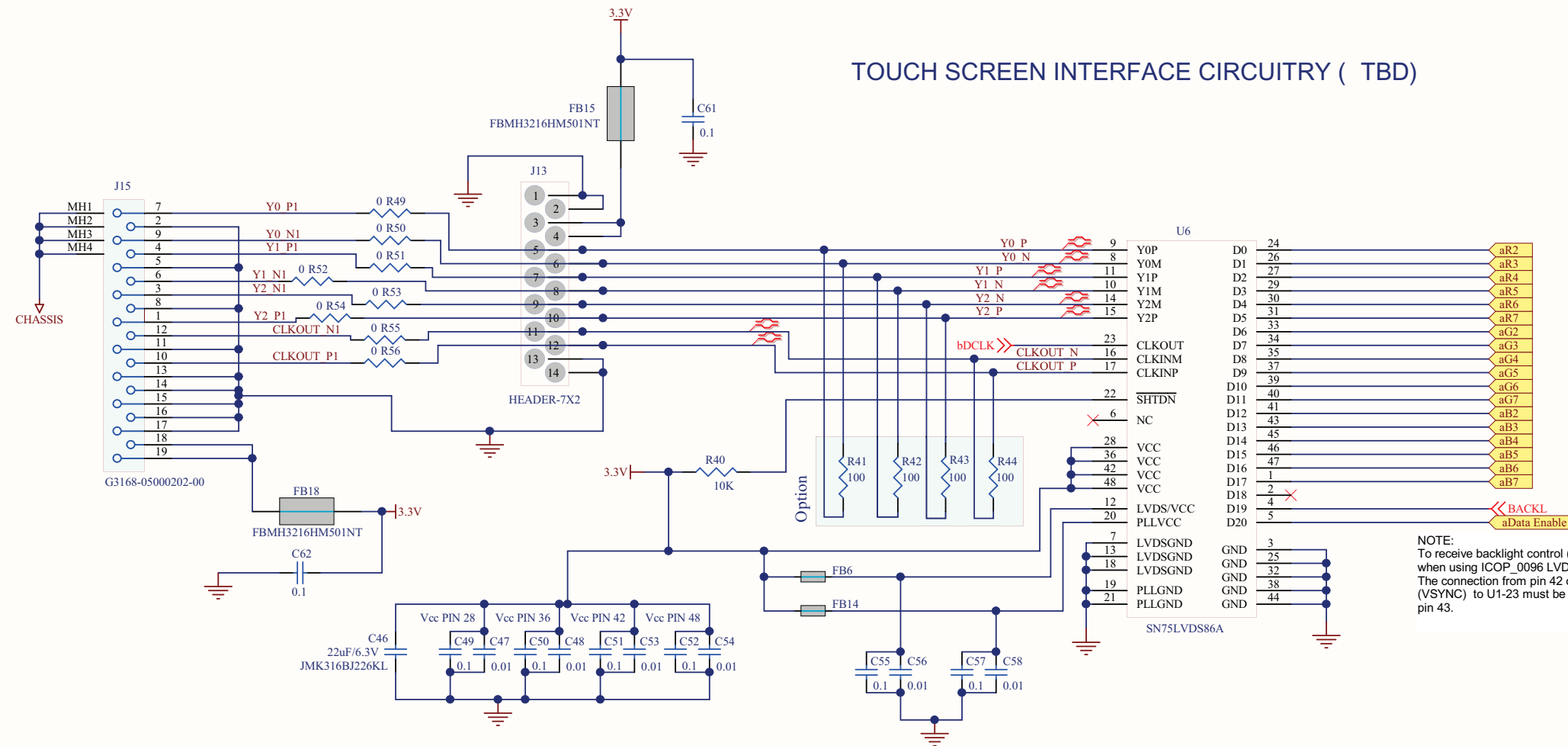

NOTE:
To receive backlight control (BACKL) from CPU board when using ICOP_0096 LVDS Transmitter. The connection from pin 42 on the TTL video connector (VSYNC) to U1-23 must be broken and connected to pin 43.

Title			GUI Interface		
Size	Number			Revision	
B	06698			D	
Date:	6/24/2010	Sheet 4 of 4			
File:	N:\PCBMGRU\06696.P4.R3.schdoc	Drawn By: RT			

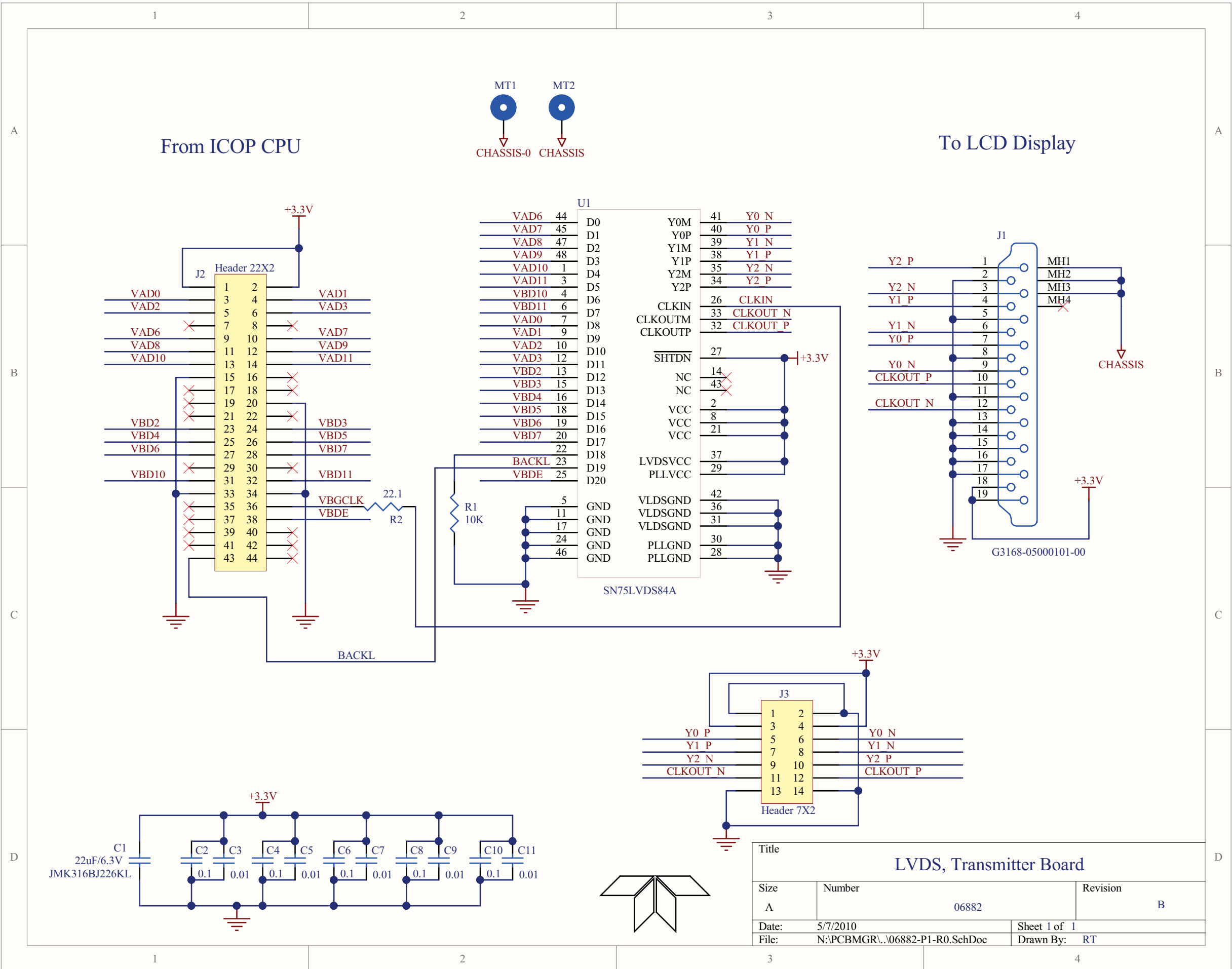

Title		
LVDS, Transmitter Board		
Size	Number	Revision
A	06882	B
Date:	5/7/2010	Sheet 1 of 1
File:	N:\PCBMGR\...\06882-P1-R0.SchDoc	Drawn By: RT

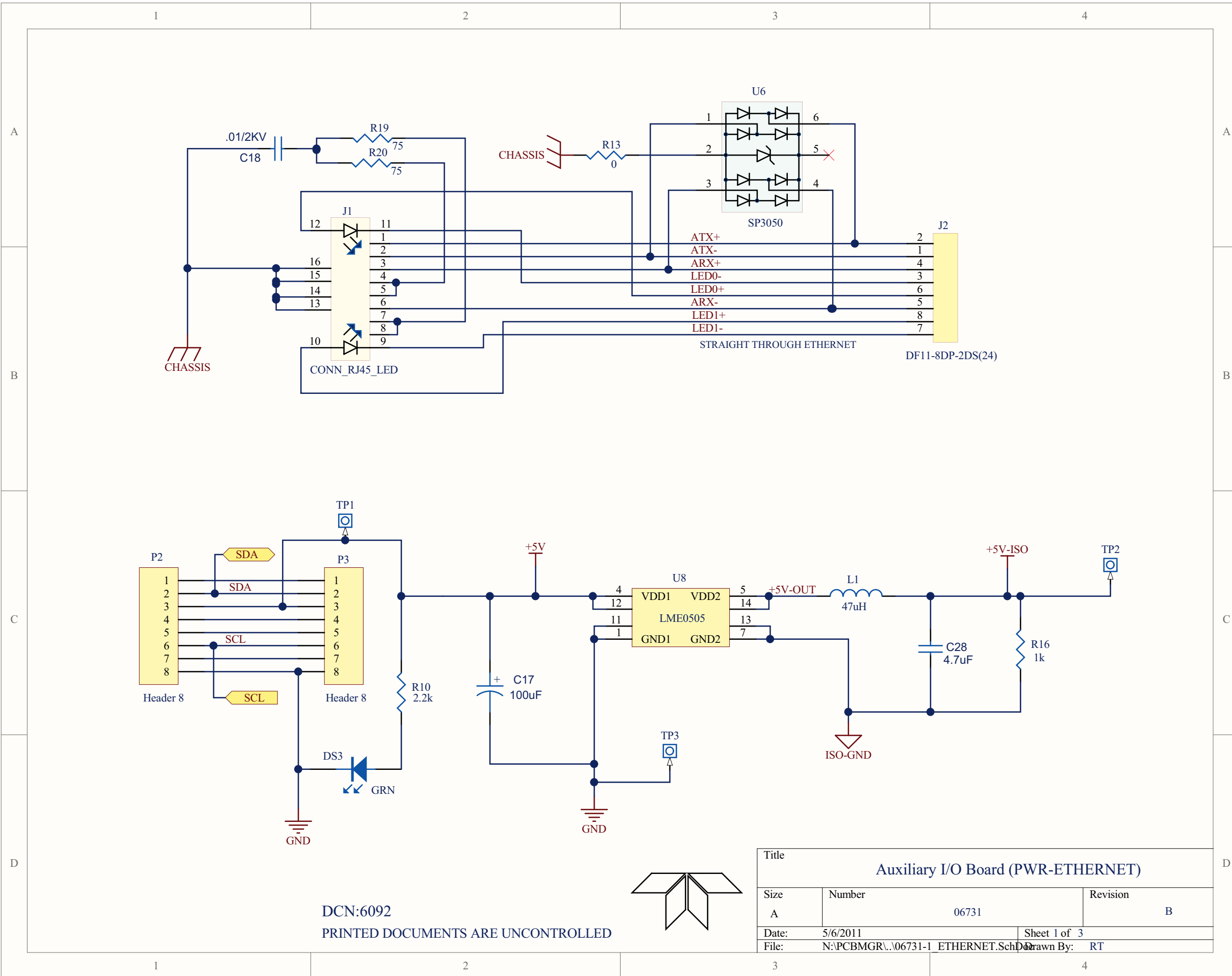

DCN:6092
 PRINTED DOCUMENTS ARE UNCONTROLLED

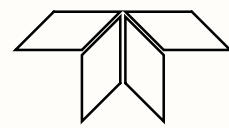

Title			
Auxiliary I/O Board (PWR-ETHERNET)			
Size	Number	Revision	
A	06731	B	
Date:	5/6/2011	Sheet 1 of 3	
File:	N:\PCBMGR\06731-1 ETHERNET.SchDoc	Drawn By:	RT

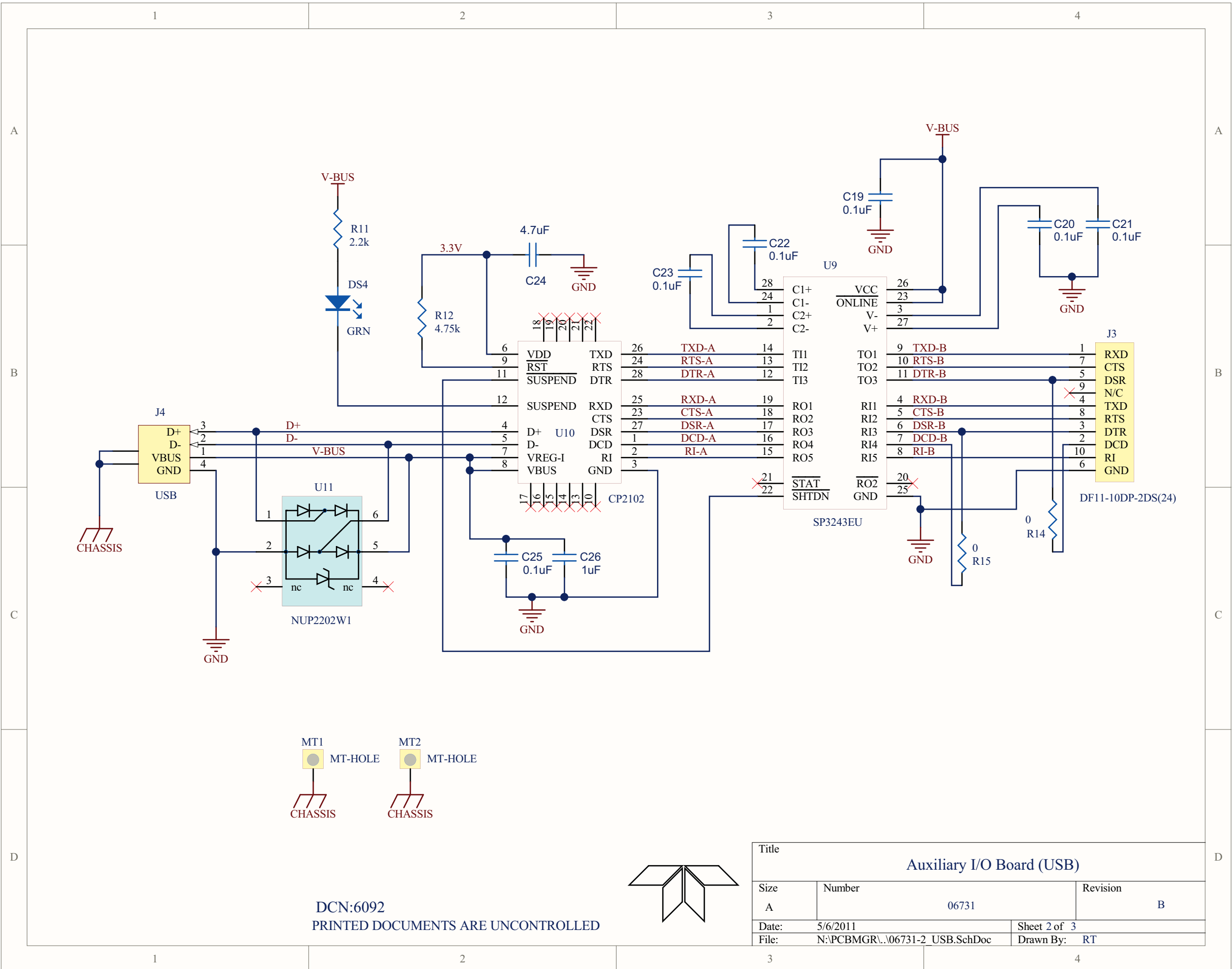

DCN:6092
 PRINTED DOCUMENTS ARE UNCONTROLLED

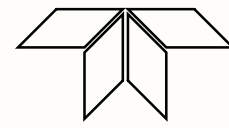

Title			
Auxiliary I/O Board (USB)			
Size	Number	Revision	
A	06731	B	
Date:	5/6/2011	Sheet 2 of 3	
File:	N:\PCBMGR\...06731-2 USB.SchDoc	Drawn By: RT	

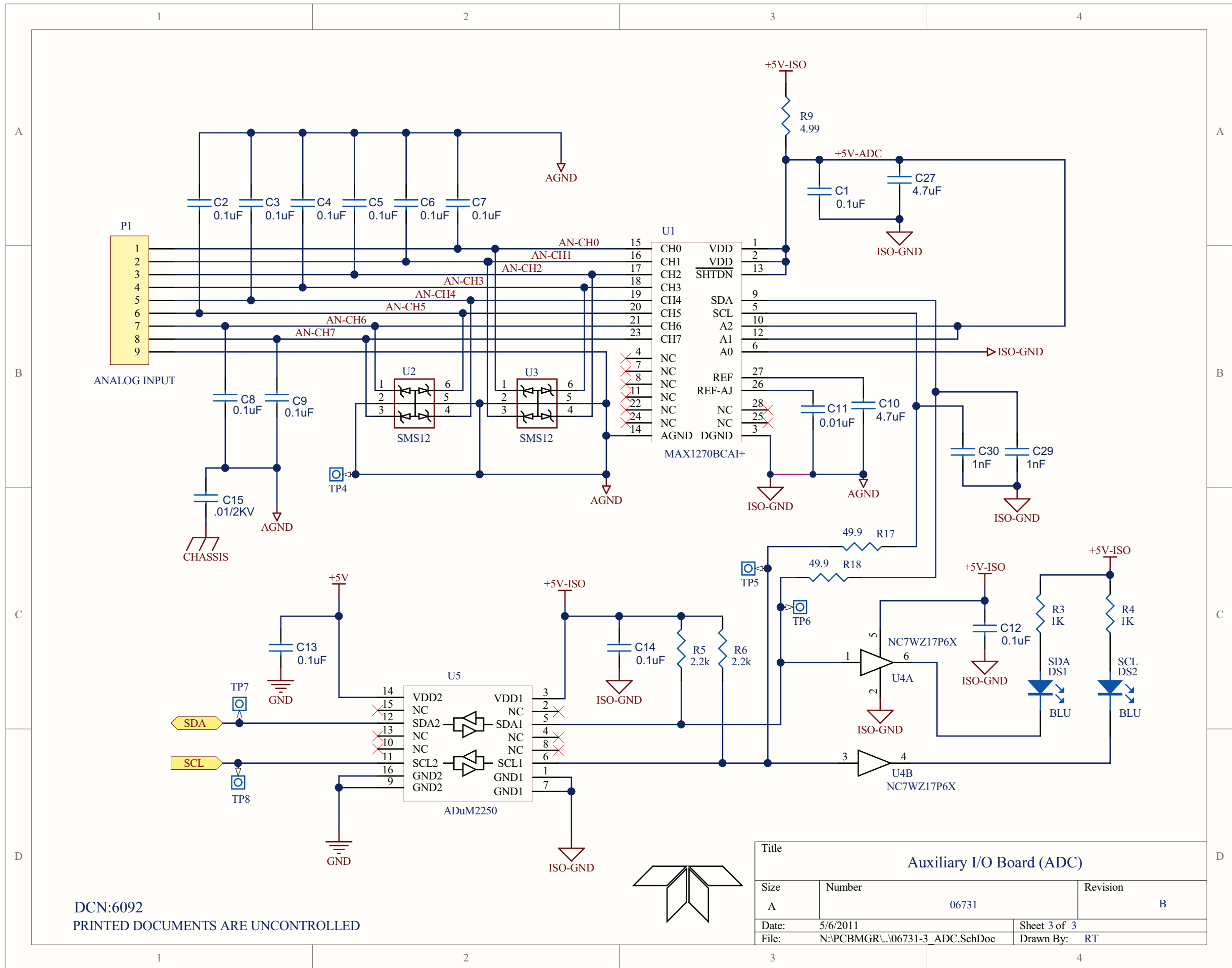

DCN:6092
PRINTED DOCUMENTS ARE UNCONTROLLED

Title			
Auxiliary I/O Board (ADC)			
Size	Number	Revision	
A	06731	B	
Date:	5/6/2011	Sheet 3 of 3	
File:	N:\PCBMGR\...06731-3_ADC.SchDoc	Drawn By: RT	